



**INSTRUMENTS**

# **M2 Transmitter Operator's Manual**

**Part Number: 71-0107RK**

**Revision: B**

**Released: 1/29/08**

**RKI Instruments, Inc.  
[www.rkiinstruments.com](http://www.rkiinstruments.com)**

---

## Product Warranty

RKI Instruments, Inc., warrants gas alarm equipment sold by us to be free from defects in materials, workmanship, and performance for a period of one year from date of shipment from RKI Instruments, Inc. Any parts found defective within that period will be repaired or replaced, at our option, free of charge. This warranty does not apply to those items which by their nature are subject to deterioration or consumption in normal service, and which must be cleaned, repaired, or replaced on a routine basis. Examples of such items are:

- a) Absorbent cartridges
- b) Pump diaphragms and valves
- c) Fuses
- d) Batteries
- e) Filter elements

Warranty is voided by abuse including mechanical damage, alteration, rough handling, or repair procedures not in accordance with the operator's manual. This warranty indicates the full extent of our liability, and we are not responsible for removal or replacement costs, local repair costs, transportation costs, or contingent expenses incurred without our prior approval.

*THIS WARRANTY IS EXPRESSLY IN LIEU OF ANY AND ALL OTHER WARRANTIES AND REPRESENTATIONS, EXPRESSED OR IMPLIED, AND ALL OTHER OBLIGATIONS OR LIABILITIES ON THE PART OF RKI INSTRUMENTS, INC., INCLUDING BUT NOT LIMITED TO, THE WARRANTY OF MERCHANTABILITY OR FITNESS FOR A PARTICULAR PURPOSE. IN NO EVENT SHALL RKI INSTRUMENTS, INC., BE LIABLE FOR INDIRECT, INCIDENTAL, OR CONSEQUENTIAL LOSS OR DAMAGE OF ANY KIND CONNECTED WITH THE USE OF ITS PRODUCTS OR FAILURE OF ITS PRODUCTS TO FUNCTION OR OPERATE PROPERLY.*

This warranty covers instruments and parts sold to users by authorized distributors, dealers, and representatives as appointed by RKI Instruments, Inc.

We do not assume indemnification for any accident or damage caused by the operation of this gas monitor, and our warranty is limited to the replacement of parts or our complete goods.

# Table of Contents

<b>Chapter 1: Introduction</b> .....	<b>5</b>
Overview .....	5
About the M2 Transmitter .....	5
About this Manual.....	5
Specifications .....	6
<b>Chapter 2: Description</b> .....	<b>8</b>
Overview .....	8
External Description .....	8
Internal Description .....	12
<b>Chapter 3: Installation &amp; Startup</b> .....	<b>16</b>
Overview .....	16
Mounting the M2 Transmitter .....	16
Wiring the M2 Transmitter .....	20
Start Up .....	25
<b>Chapter 4: Operation</b> .....	<b>27</b>
Overview .....	27
Normal Operation .....	27
Information Screen.....	27
4 - 20 mA Signal Output Operation .....	28
Alarm Indications .....	28
<b>Chapter 5: Configuration Mode</b> .....	<b>32</b>
Overview .....	32
Viewing & Changing M2 Parameters .....	32
<b>Chapter 6: Gas Type Mode</b> .....	<b>35</b>
Overview .....	35
Selecting the Gas Type .....	35

<b>Chapter 7: Maintenance</b> .....	<b>38</b>
Overview.....	38
Preventive Maintenance .....	38
Troubleshooting .....	40
Calibration Frequency.....	42
Calibration, Combustible Gas, CO <sub>2</sub> , and Toxic Versions .....	42
Calibration, Oxygen Version .....	46
Replacing Components of the M2 .....	49
<b>Chapter 8: RS-485 Modbus Output</b> .....	<b>52</b>
Overview.....	52
Wiring the M2 in a Modbus System .....	52
Using the M2 in a 4-wire Modbus System .....	55
Modbus Mode .....	55
Supported Modbus Functions .....	57
<b>Parts List</b> .....	<b>60</b>
<b>Appendix A: Control Button Quick Reference Guide</b> .....	<b>63</b>

# Chapter 1: Introduction

---

## Overview

This chapter briefly describes the M2 Transmitter. This chapter also describes the *M2 Transmitter Operator's Manual* (this document). Table 1 at the end of this chapter lists the specifications for the M2.

---

## About the M2 Transmitter

The M2 Transmitter is a fixed mount, continuous-monitoring detector head. All user adjustable parameters may be accessed using push button switches. In addition, calibration may be performed non-intrusively by use of a magnetic wand accessory which activates magnetic switches through a window at the front face of the detector head.

The M2 displays the current gas reading on an LCD display which is visible through the window in the cover (front face) and provides a 4 - 20 mA signal which indicates the target gas reading for use by a gas monitoring controller, recording device, or programmable controller. The M2 also provides an RS-485 Modbus output. Three sets of relay contacts, two controlled by the gas alarms and one by the fail alarm, rated at 115 VAC 5 amps are available for controlling devices such as lights or horns or for controlling higher rated relays.

Four operating modes allow you to display and change setup and calibration settings and change the gas type. They are Calibration Mode, Configuration Mode, Gas Type Mode, and Modbus Mode.

---

## About this Manual

The *M2 Transmitter Operator's Manual* uses the following conventions for notes, cautions, and warnings.

---

**NOTE:** Describes additional or critical information.

---

---

**CAUTION:** Describes potential damage to equipment.

---

---

**WARNING:** Describes potential danger that can result in injury or death.

---

## Specifications

Table 1 lists specifications for the M2.

**Table 1: M2 Specifications**

Target Gas/Detection Range	<p><b><u>Combustible Gas/Carbon Dioxide (CO<sub>2</sub>)</u></b></p> <ul style="list-style-type: none"> <li>Catalytic LEL: 0 - 100% LEL, 1% LEL increments (CH<sub>4</sub> calibration unless otherwise specified., H<sub>2</sub> specific detector available)</li> <li>IR (infrared) CH<sub>4</sub> LEL: 0 - 100% LEL, 1% LEL increments</li> <li>IR HC LEL: 0 - 100% LEL, 1% LEL increments (propane calibration)</li> <li>IR CH<sub>4</sub> Volume: 0 - 100 % volume, 1% increments</li> <li>IR CO<sub>2</sub> ppm.: 0 - 5,000 ppm, 20 ppm increments</li> <li>IR CO<sub>2</sub> Volume: 0 - 5.00 % volume, .01% increments</li> </ul> <p><b><u>Oxygen</u></b></p> <ul style="list-style-type: none"> <li>Oxygen (O<sub>2</sub>): 0 - 25.0 % volume, 0.1% increments</li> </ul> <p><b><u>CSA Type Toxic</u></b></p> <ul style="list-style-type: none"> <li>Carbon Monoxide (CO): 0 - 300 ppm, 1 ppm increments</li> <li>Hydrogen Sulfide (H<sub>2</sub>S): 0 - 100 ppm, 1 ppm increments</li> </ul> <p><b><u>ESM-01 Toxic</u></b></p> <ul style="list-style-type: none"> <li>Ammonia (NH<sub>3</sub>): 0 - 75.0 ppm, 0.1 ppm increments</li> <li>Arsine (AsH<sub>3</sub>): 0 - 1.50 ppm, 0.01 ppm increments</li> <li>Chlorine (Cl<sub>2</sub>): 0 - 3.00 ppm, 0.01 ppm increments</li> <li>Nitric Oxide (NO): 0 - 100 ppm, 1 ppm increments</li> <li>Phosphine (PH<sub>3</sub>): 0 - 1.00 ppm, 0.01 ppm increments</li> <li>Sulphur Dioxide (SO<sub>2</sub>): 0 - 6.00 ppm, 0.01 ppm increments</li> </ul>
Alarm Settings (Alarm 1/Alarm 2)	<p><b>Combustible Gas (%LEL):</b> 10 %LEL/50 %LEL  <b>Combustible Gas (%Volume):</b> 100 %/100 %  <b>CO2 0 - 5,000 ppm:</b> 2,500 ppm/5,000 ppm  <b>CO2 0 - 5.00%:</b> 0.50 %/3.00 %  <b>Oxygen:</b> 19.5%(decreasing)/23.5%(increasing)  <b>Carbon Monoxide:</b> 25 ppm/50 ppm  <b>Hydrogen Sulfide:</b> 10 ppm/50 ppm  <b>Ammonia:</b> 12 ppm/25 ppm  <b>Arsine:</b> 0.20 ppm/0.50ppm  <b>Chlorine:</b> 0.50 ppm/1.50 ppm  <b>Nitric Oxide:</b> 10 ppm/25 ppm  <b>Phosphine:</b> 0.10 ppm/0.30 ppm  <b>Sulphur Dioxide:</b> 1.00 ppm/2.00 ppm</p>
Construction (housing)	Explosion-proof Junction Box, NEMA 4
Area Classification	Explosion-proof for Class I, Groups B, C, and D (Combustible, CO <sub>2</sub> , CSA Type Toxic, and CSA Type oxygen)
Sampling Method	Diffusion
Input Power	19 - 30 VDC

**Table 1: M2 Specifications**

Controls	<ul style="list-style-type: none"><li>• Three push button switches</li><li>• Three magnetic switches for non-intrusive calibration</li></ul>
Weight	4.5 lbs.
Signal Output	<ul style="list-style-type: none"><li>• 4 to 20 mA, 500 ohms impedance max</li><li>• RS-485 Modbus</li></ul>
Operating Temperature	<ul style="list-style-type: none"><li>• ESM-01 Type: -10°C to 40 °C</li><li>• All Others: -20°C to 50°C</li></ul>
Accuracy	± 5% of full scale
<p>* These are the RKI factory settings. You can change the alarm settings in Configuration Mode. See “Viewing &amp; Changing M2 Parameters” on page 32.</p>	

# Chapter 2: Description

---

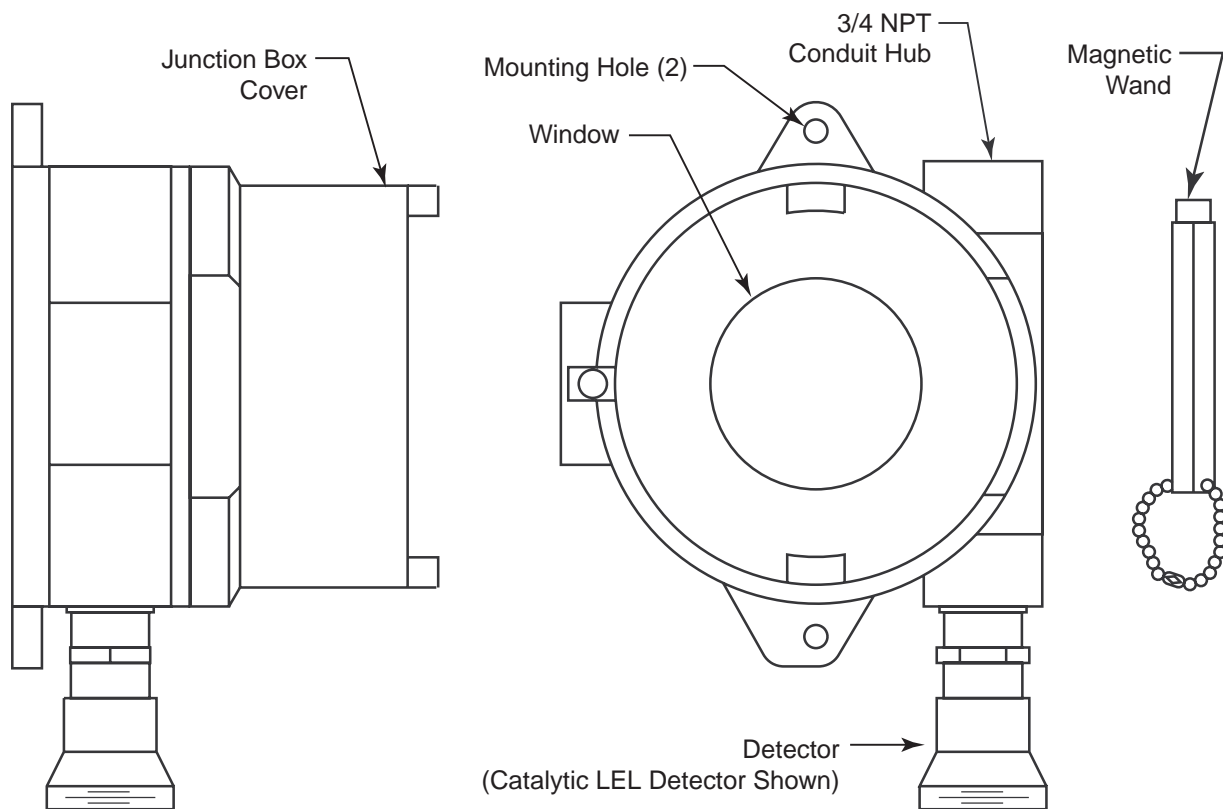
## Overview

This chapter describes external and internal components of the M2 Transmitter.

---

## External Description

This section describes the junction box and all external components of the M2 transmitter.



**Figure 1: M2 External Components**

### Junction Box

The M2's cast aluminum junction box is dust and weather resistant. The junction box also protects the M2 and all connections made to it. Use the two 3/4 in. conduit hubs to mount the detector to the junction box (factory installed in the bottom hub) and connect wiring from an external device (top hub).

Use the junction box's two mounting holes to mount the M2 to a vertical surface at the monitoring site. The window in the cover on the front of the junction box allows you to view the LCD display and use the magnetic wand to actuate the magnetic control switches so you can perform non-intrusive calibration. Removing the cover allows you to access the interior of the junction box.

## Magnetic Wand

The magnetic wand is a short plastic rod with a magnet in one end. It is used to actuate the magnetic control switches on the control PCB while the junction box cover is still installed so that non-intrusive calibration can be performed.

## Gas Detector

The gas detector senses the target gas and is mounted in a 3/4" conduit hub on the right bottom side of the M2. A variety of detectors may be used with the M2. Table 2 below lists the detectors that can be used with the M2.

**Table 2: M2 Detectors**

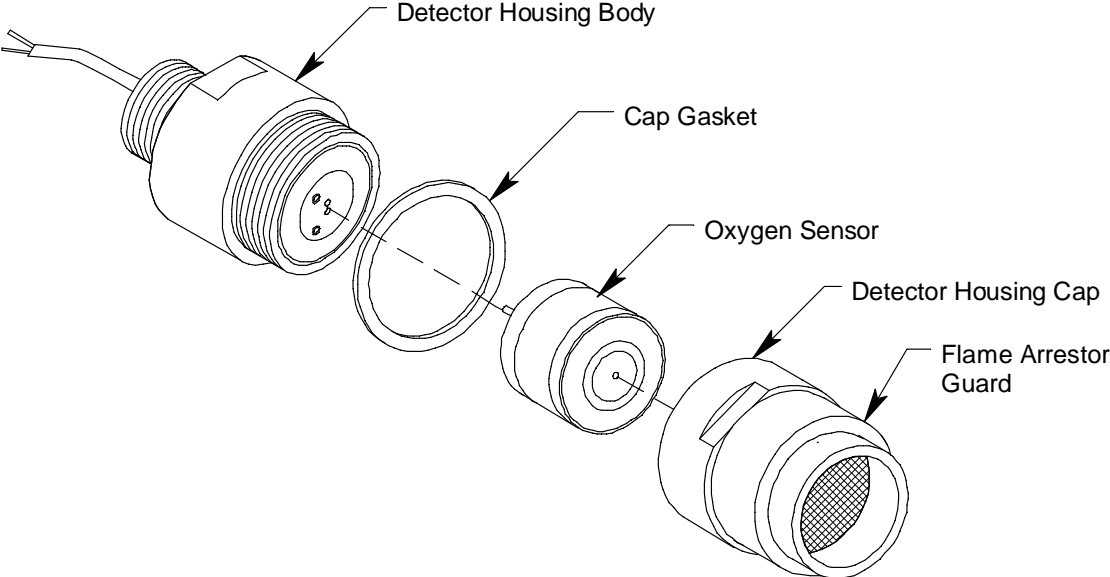
Target Gas, Range	Detector(s) Used
Combustible Gas, 0 - 100% LEL	<ul style="list-style-type: none"> <li>61-0140RK (Catalytic UL version)</li> <li>61-0140RK-05 (Catalytic CSA version)</li> </ul>
Hydrogen, 0 - 100% LEL	<ul style="list-style-type: none"> <li>NC-6234-01 (Catalytic UL version, hydrogen specific)</li> <li>NC-6234-05 (Catalytic CSA version, hydrogen specific)</li> </ul>
CH <sub>4</sub> , 0 - 100% LEL	<ul style="list-style-type: none"> <li>61-0190RK-CH4 (IR UL)</li> </ul>
HC, 0 - 100% LEL (cal. to propane)	<ul style="list-style-type: none"> <li>61-0190RK-HC (IR UL)</li> </ul>
CH <sub>4</sub> , 0 - 100% volume	<ul style="list-style-type: none"> <li>61-0192RK-CH4 (IR UL)</li> </ul>
CO <sub>2</sub> , 0 - 5,000 ppm	<ul style="list-style-type: none"> <li>61-0191RK-02 (IR UL)</li> </ul>
CO <sub>2</sub> , 0 - 5%	<ul style="list-style-type: none"> <li>61-0191RK-03 (IR UL)</li> </ul>
Oxygen, 0 - 25%	<ul style="list-style-type: none"> <li>65-2510RK (partial pressure)</li> <li>65-2511RK (capillary)</li> <li>65-2514RK (capillary, CSA)</li> </ul>
CO, 0 - 300 ppm	<ul style="list-style-type: none"> <li>65-2433RK-05 (CSA)</li> </ul>
H <sub>2</sub> S, 0 - 100 ppm	<ul style="list-style-type: none"> <li>65-2423RK-05 (CSA)</li> </ul>
NH <sub>3</sub> , 0 - 75 ppm	<ul style="list-style-type: none"> <li>65-2300RK-NH3</li> </ul>
AsH <sub>3</sub> , 0 - 1.5 ppm	<ul style="list-style-type: none"> <li>65-2300RK-ASH3</li> </ul>
Cl <sub>2</sub> , 0 - 3 ppm	<ul style="list-style-type: none"> <li>65-2300RK-CL2</li> </ul>
PH <sub>3</sub> , 0 - 1 ppm	<ul style="list-style-type: none"> <li>65-2300RK-PH3</li> </ul>
SO <sub>2</sub> , 0 - 6 ppm	<ul style="list-style-type: none"> <li>65-2300RK-SO2</li> </ul>

The catalytic LEL detectors have a 1/2" NPT thread and require a 3/4" NPT x 1/2" NPT reducer to install in the detector hub. The rest of the detectors have a 3/4" NPT mounting thread and are installed directly in the detector hub.

The IR combustible detectors are generally used instead of the catalytic combustible detectors in applications where there may be catalyst poisons such as silicone present or where oxygen is not present in the monitoring environment.

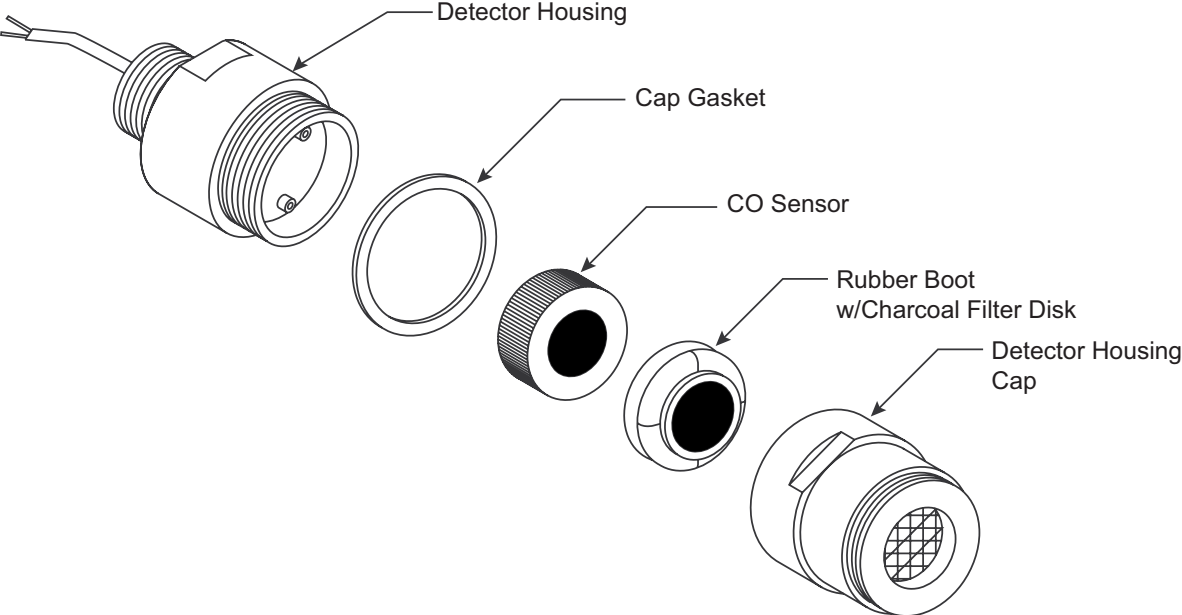
Some of the detectors have a replaceable plug-in sensor. These detectors are described and illustrated below.

There are three types of oxygen detectors available, a non-explosion proof partial pressure type, a non-explosion proof capillary type, and an explosion proof (CSA) capillary type. The capillary type's output is less susceptible to variations in atmospheric pressure than the partial pressure type. The CSA type oxygen detector (65-2514RK) has a replaceable plug-in sensor inside the detector housing while the entire oxygen detector must be removed if replacement is required for the other two.

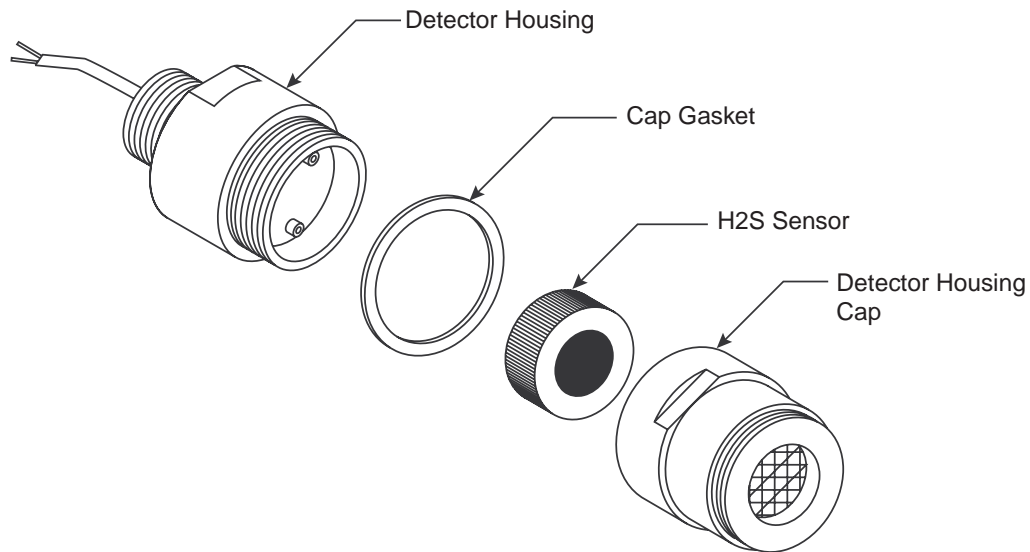


**Figure 2: 65-2614RK Oxygen detector**

The CSA type CO and H<sub>2</sub>S detectors have replaceable plug-in sensors inside the detector housing. The CO detector includes a charcoal filter disk which is held onto the sensor with a rubber retaining boot. The charcoal filter disk scrubs out interfering gases to which the CO sensor responds such as H<sub>2</sub>S and certain hydrocarbons.

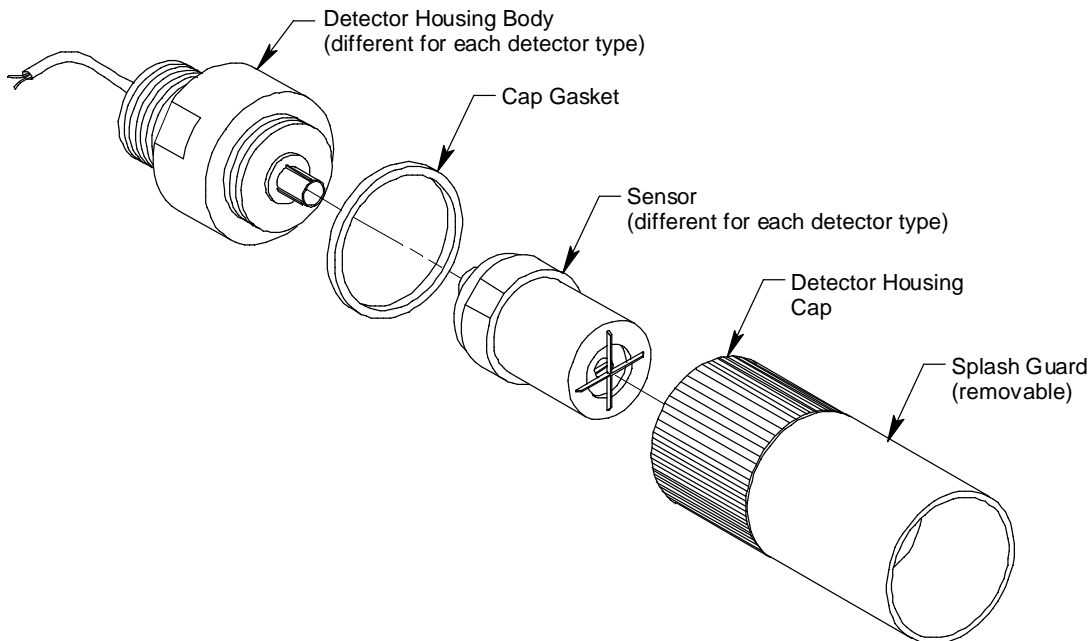


**Figure 3: 65-2433RK-05CO Detector**



**Figure 4:65-2423RK-05 H<sub>2</sub>S Detector**

The construction of the various ESM-01 detectors is similar. Each of the ESM-01 detectors has a different replaceable plug-in sensor that protrudes through the detector housing cap. Although ESM-01 detectors look the same except for the plug-in detector, the detector housing which includes the detector socket and conditioning circuitry is specific to a sensor type. For example, a detector housing from a Cl<sub>2</sub> detector cannot be used with an NH<sub>3</sub> detector. One of the two detector wires is color coded for each specific detector type. The ESM-01 detectors include a removable splashguard that screws onto the detector housing cap. When it is necessary to apply gas to an ESM-01 detector, remove the splashguard to allow access to the sensor that protrudes through the detector housing cap. You can then push the appropriate ESM-01 calibration cup onto the sensor.



**Figure 5: ESM-01 Type Detector**

## Internal Description

This section describes the internal components of the M2. The internal components of the M2 include the terminal PCB which provides for all the wiring connections to the M2 and the control PCB which displays the gas reading and has the control buttons.

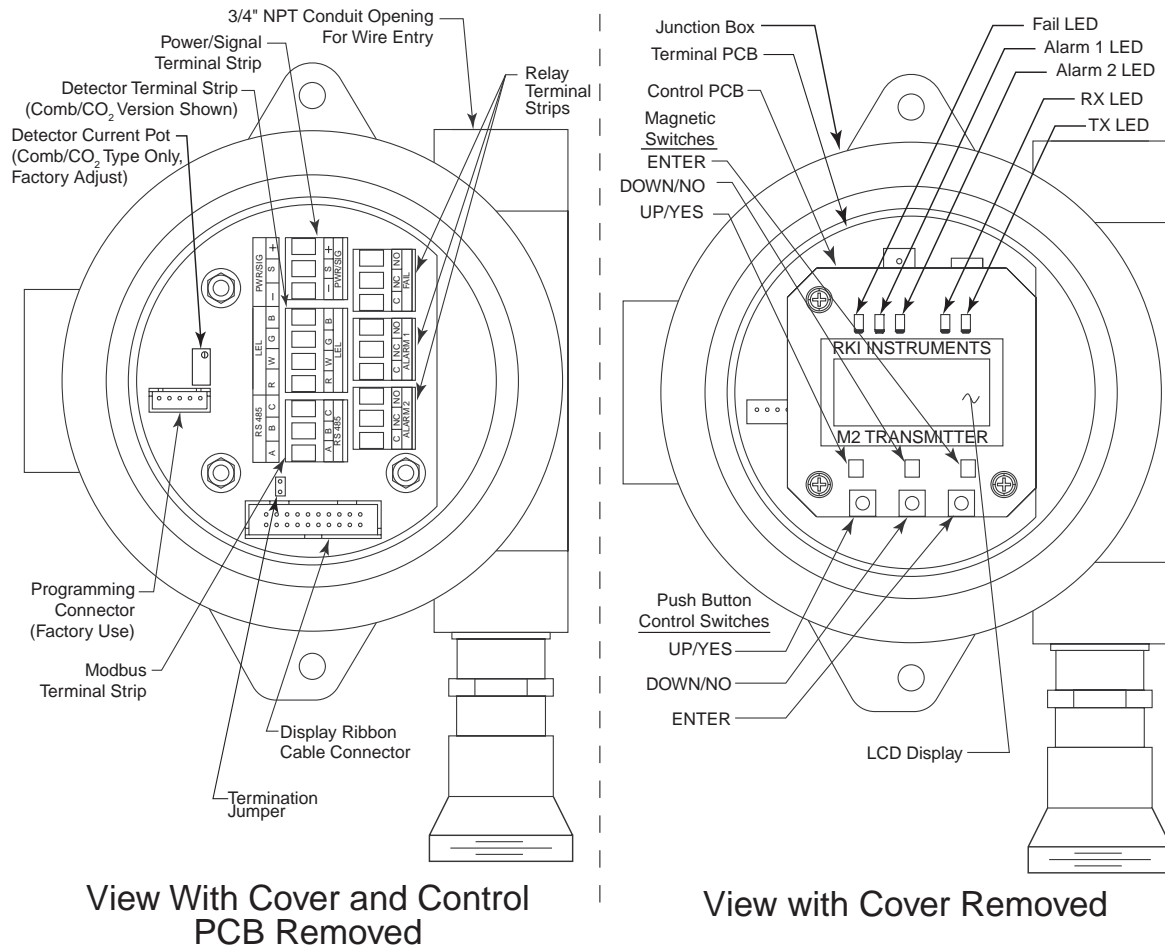


Figure 6: M2 Internal Components

### Terminal PCB

The terminal PCB is encapsulated in epoxy for protection against moisture and physical damage. It is mounted into the rear of the junction box with three standoffs and rests on a thin layer of foam. A banana jack is screwed into each of the standoffs and used for mounting the control PCB. The terminal PCB converts the electrical output from the detector to a signal which can be displayed by the LCD display, a 4 - 20 mA signal (that is proportional to the detection range) and an RS-485 Modbus output signal. The 4 - 20 mA signal may be used by a recording device, gas monitor controller, or programmable controller. The Modbus output may be used to connect the M2 to a Modbus network. The terminal PCB also controls three relays, one fail and two gas alarm relays.

Two columns of plug-in style terminal strips are used to make all wiring connections to the M2. The column on the left consists of the power/signal, detector, and Modbus terminal strips. The column on the right consists of the relay terminal strips. A 20 position

connector at the bottom of the terminal PCB is used to connect the terminal PCB to the control PCB with a ribbon cable. A 5 position connector on the left side of the terminal PCB is used by factory or field service personnel to program the M2. On the combustible and CO<sub>2</sub> versions of the M2, a factory adjust pot just above the programming connector is used to set the detector current

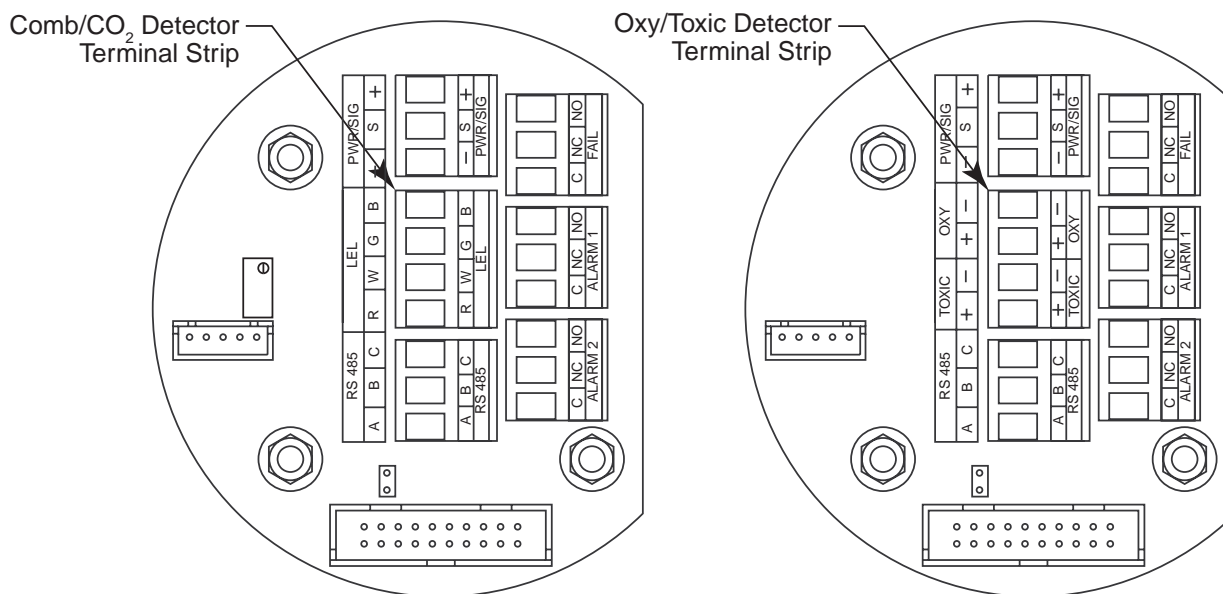
### **Power/Signal Terminal Strip**

The power/signal terminal strip is a three position plug-in style terminal strip located at the top of the left terminal column. It is used to connect 24 VDC power to the M2 and to connect the 4 - 20 mA output signal to a device.

The signal output, the S terminal, does not have to be connected for the M2 to function. The S terminal is used if you want to connect the 4 - 20 mA output signal to another device such as a gas monitoring controller, chart recorder, or programmable controller (PLC).

### **Detector Terminal Strip**

The detector terminal strip is a four position plug-in style terminal strip and is the middle terminal strip in the left terminal column. For a combustible or CO<sub>2</sub> M2, all four terminals are used to connect the detector to the M2. For a toxic or oxygen M2, only two of the terminals are used for connecting a detector: two terminals are dedicated for connecting a toxic detector and two are dedicated for connecting an oxygen detector (only one detector can be installed).



**Figure 7: Detector Terminal Strip**

---

**NOTE:** The detector is factory-wired to the M2. See “Wiring the M2 Transmitter” on page 20. for all wiring procedures related to M2.

---

### **Modbus Terminal Strip**

The Modbus terminal strip is a three position plug-in style terminal strip and is the bottom terminal strip in the left terminal column. It allows connection of the M2 into a Modbus network.

### **Relay Terminal Strips**

The right column of terminal strips consists of, from top to bottom, the fail, alarm 1, and alarm 2 relay terminal strips. They are three-position plug-in style terminal strips. The relay terminal strips are used to connect devices such as lights and horns that are controlled by the relay contacts. The relay contacts are rated at 115 VAC, 5 amps. The relay contacts may also be used to control higher rated relays.

### **Termination Jumper**

A two pin header with a termination jumper installed is located below the Modbus terminal strip. The jumper has no function unless the M2 is wired into a Modbus installation. See “Chapter 8: RS-485 Modbus Output” on page 52 for a description of using the M2 in a Modbus system.

### **Control PCB**

The LCD display and control switches are located on the control PCB. It is installed on top of the terminal PCB by lining up its three spacing standoffs with the banana jacks in the terminal PCB mounting standoffs and pushing it onto the banana jacks. The jacks retain the control PCB.

### **LCD Display**

The LCD display is located at the top of the control PCB. It indicates the current gas reading and displays messages and parameters in the M2’s programs.

### **Control Buttons**

The M2 includes three push button switches that allow you to enter the M2’s operating modes, navigate through the modes, update settings, and save changes to the settings. The push button switches are located along the bottom edge of the control PCB (see Figure 6). The UP/YES button is on the left, the DOWN/NO button is in the middle, and the ENTER button is on the right.

**Table 3: M2 Control Button Functions**

<b>Switch</b>	<b>Function</b>
UP (YES)	<ul style="list-style-type: none"><li>• Saves settings</li><li>• Changes the displayed setting</li><li>• Enters the Calibration Program</li><li>• Enters Gas Type Mode (press with DOWN/NO button)</li><li>• Enters Configuration Mode (press with ENTER button)</li></ul>
DOWN (NO)	<ul style="list-style-type: none"><li>• Cancels setting changes</li><li>• Changes the displayed setting</li><li>• Enters Gas Type Mode (press with UP/YES button)</li><li>• Enters Modbus Mode (press with ENTER button)</li><li>• Displays the Information Screen</li></ul>
ENTER	<ul style="list-style-type: none"><li>• Initiates operations</li><li>• Enters Configuration Mode (press with UP/YES button)</li><li>• Enters Modbus Mode (press with DOWN/NO button)</li><li>• Functions as an alarm reset switch</li></ul>

Just above each push button switch is a magnetic switch with the same function as the push button switch below it. The magnetic switches are for use in non-intrusive calibration. They are actuated by bringing the magnetic wand close enough to them to

actuate them. Although the magnetic switches have the same functions as the push button switches, it is not practical to use them for operations other than calibration because it is not possible to actuate two magnetic switches at once with only one magnetic wand. Since displaying the Information Screen only requires the use of one switch, the wand may be used to show the Information Screen (see "Information Screen" on page 27).

### ***Status LEDs***

The M2 includes five status LEDs that are located above the display (see Figure 6).

- **Fail LED**

The fail LED turns on when the M2 is experiencing a fail condition. A fail condition can be caused by a detector failure or low detector signal.

- **Alarm 1 LED**

The alarm 1 LED is on when the M2 is experiencing an alarm 1 condition.

- **Alarm 2 LED**

The alarm 2 LED is on when the M2 is experiencing an alarm 2 condition.

- **RX & TX LED's**

These LED's indicate data being received (RX) and transmitted (TX) when the M2's Modbus output is operating.

# Chapter 3: Installation & Startup

## Overview

This chapter describes procedures to mount the M2 Transmitter in the monitoring environment and wire it to input power and devices.

## Mounting the M2 Transmitter

1. Select a mounting site that is representative of the monitoring environment. Consider the following when you select the mounting site.
  - Select a site where the M2 is not likely to be bumped or disturbed. Make sure there is sufficient room to perform start-up, maintenance, and calibration procedures.
  - Select a site where the target gas is likely to be found first. For lighter gases, mount the detector near the ceiling; for heavier gases, mount the detector near the floor.
2. At the monitoring site, use #10 screws through the junction box's two mounting holes to secure the junction box to a vertical surface. Figure 8 - Figure 12 show the outline and mounting dimensions for each version of the M2. Mount the M2 with the detector facing down as shown in the figures.

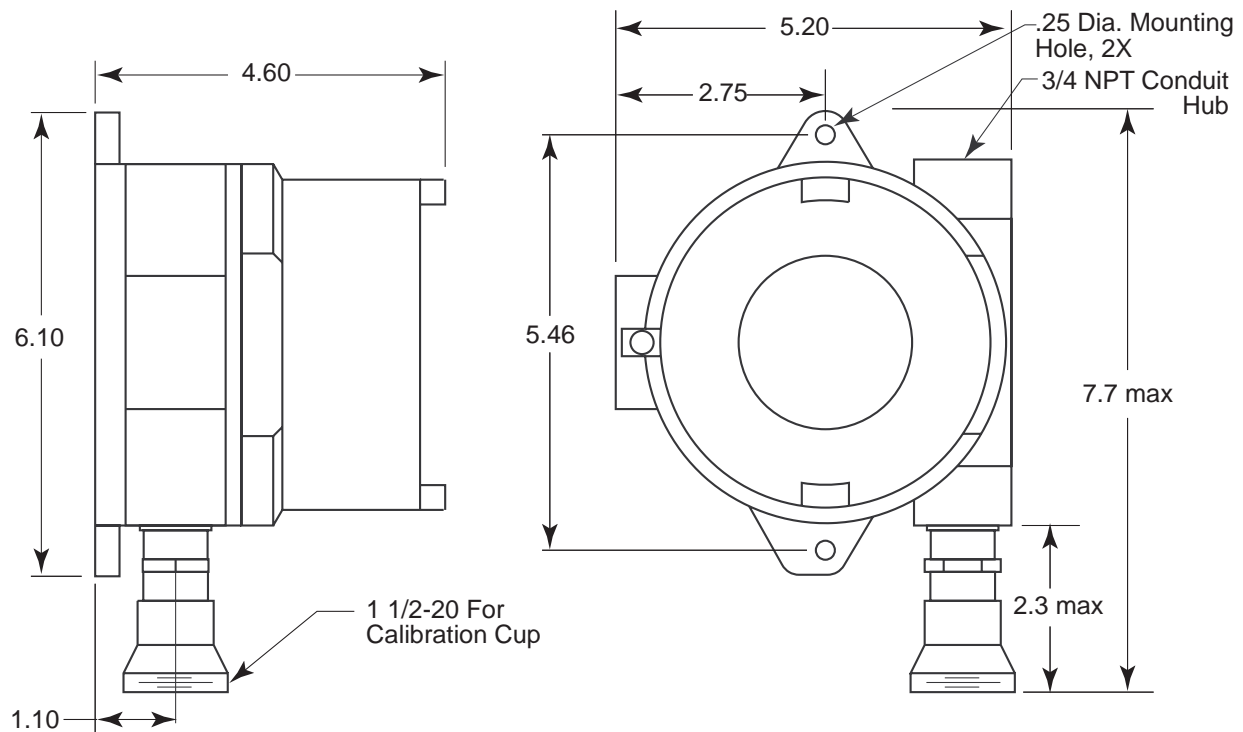
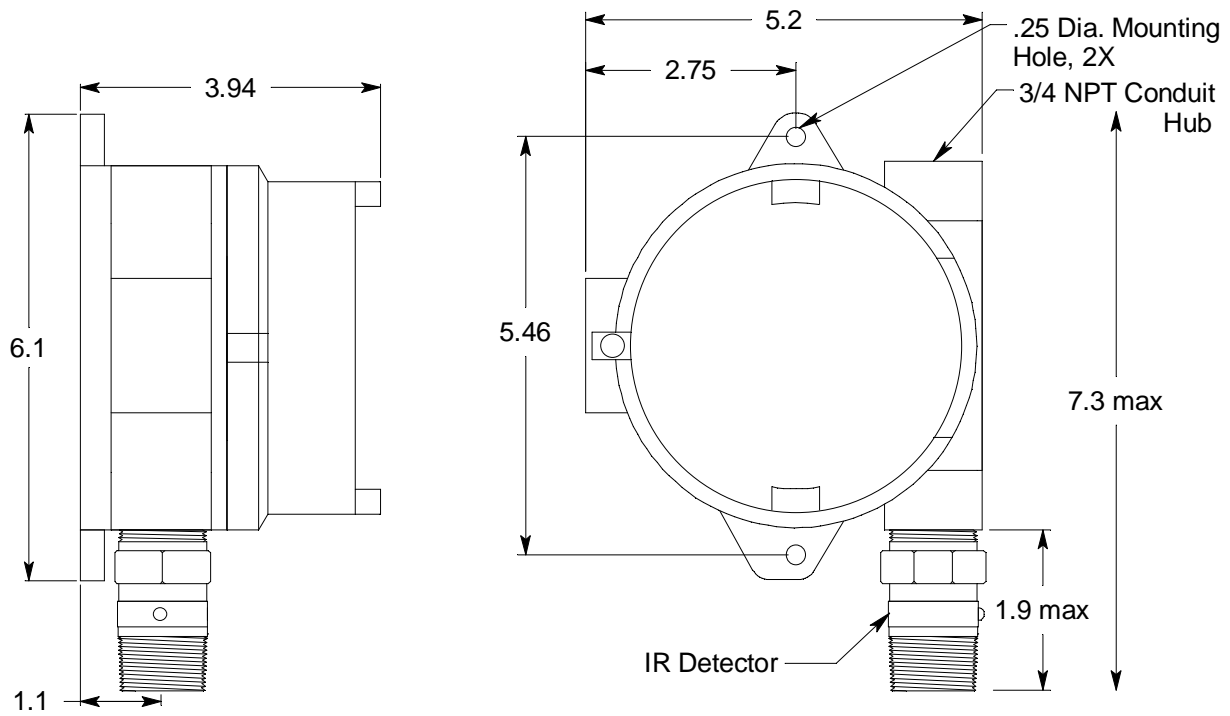
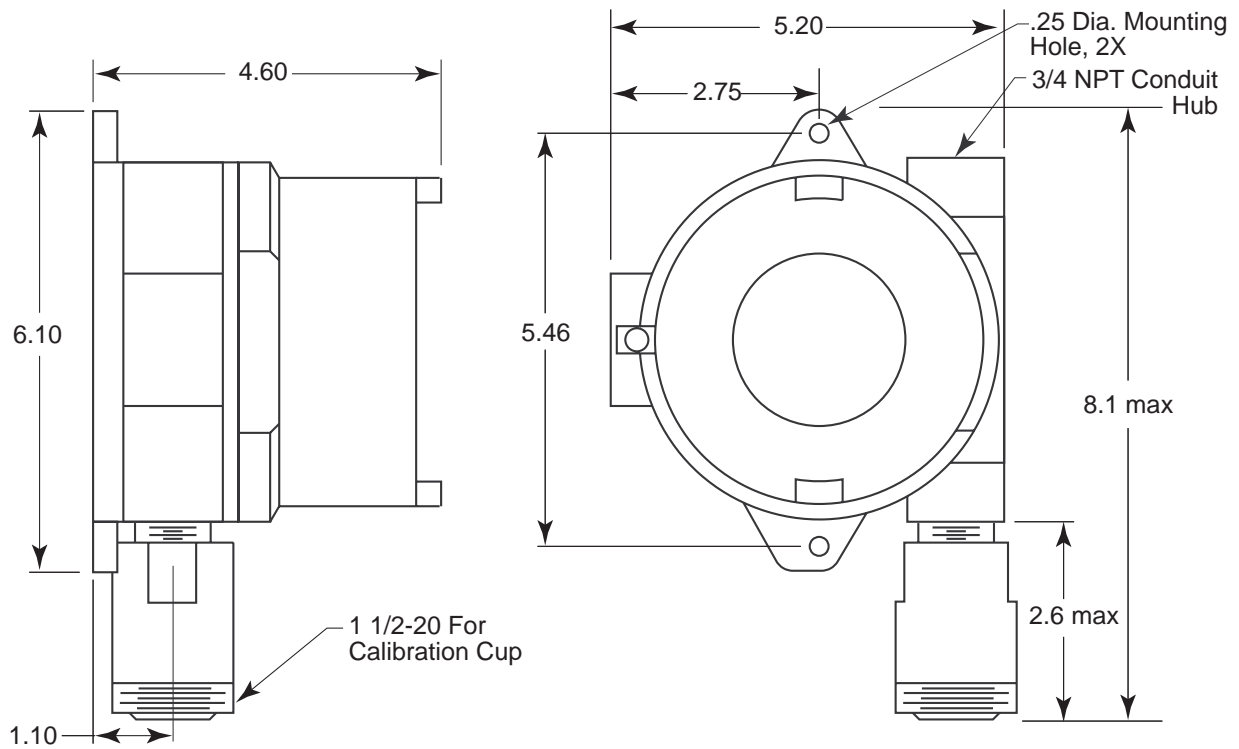


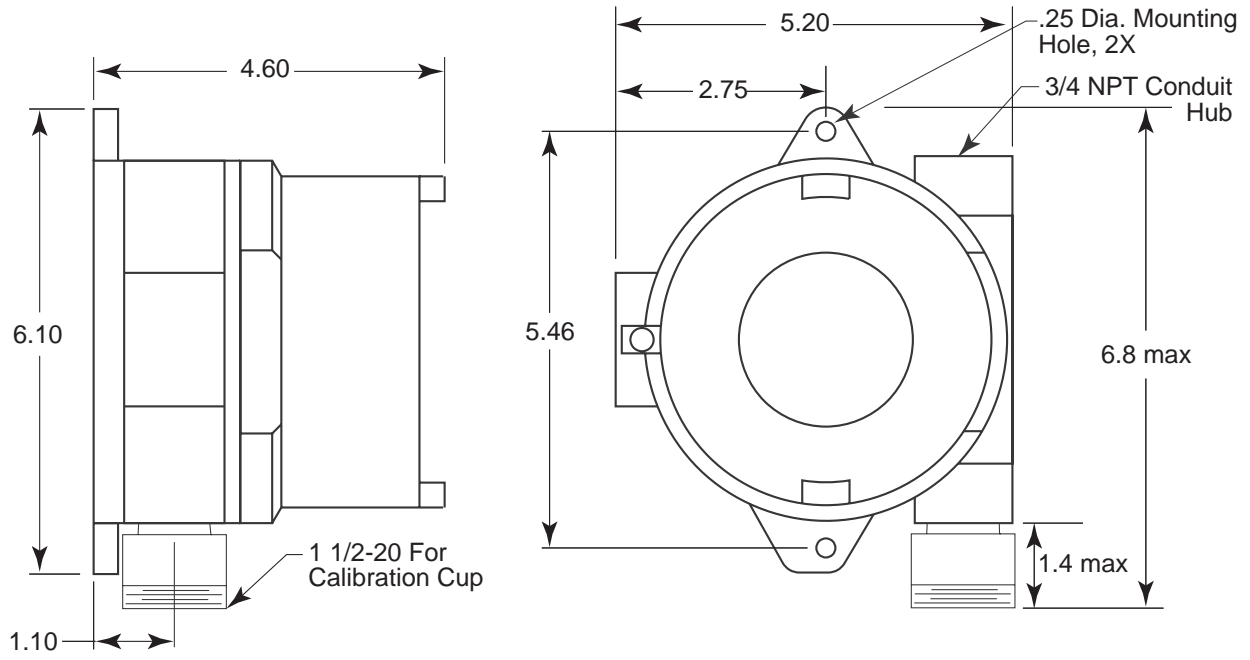
Figure 8: Outline & Mounting Dimensions, Catalytic LEL



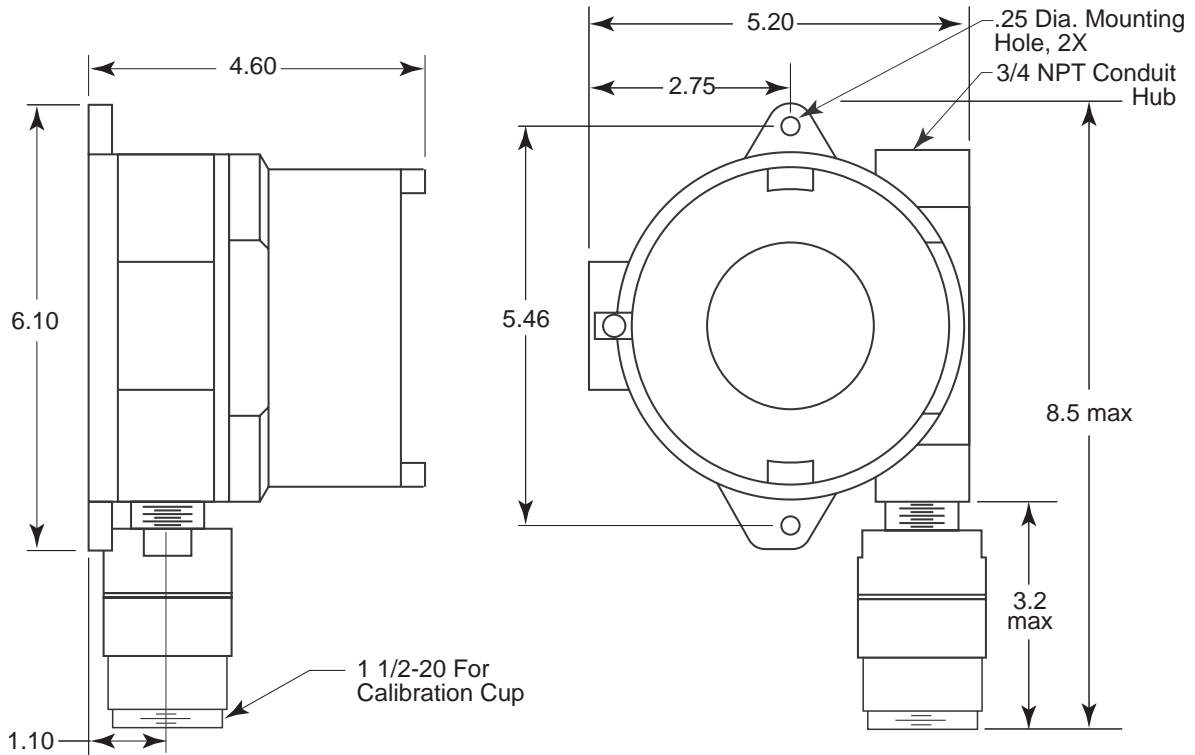
**Figure 9: Outline & Mounting Dimensions, IR Combustible & CO<sub>2</sub>**



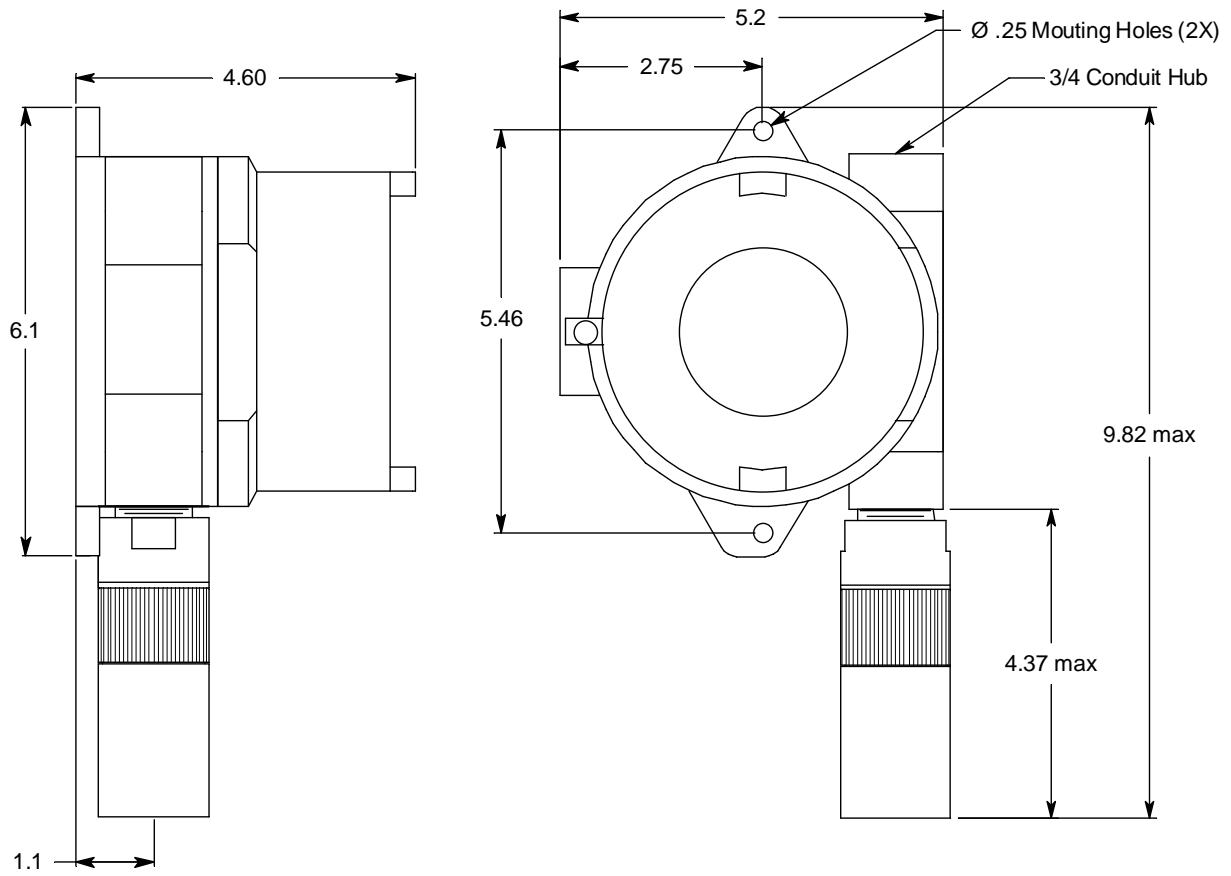
**Figure 10: Outline & Mounting Dimensions, Oxygen, Partial Pressure Type**



**Figure 11: Outline & Mounting Dimensions, Oxygen, Capillary Type**



**Figure 12: Outline & Mounting Dimensions, CSA Type H<sub>2</sub>S, CO, and Oxygen**



**Figure 13: Outline & Mounting Dimensions, ESM-01 Toxic**

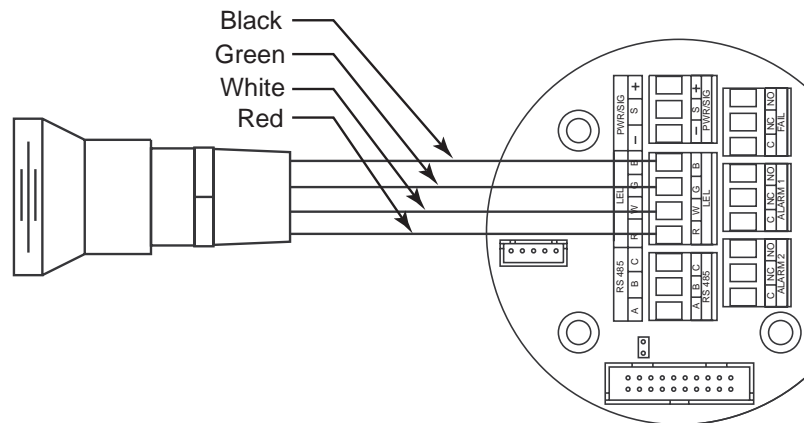
## Wiring the M2 Transmitter

**WARNING:** Always verify that the power source is OFF before making any wiring connections.

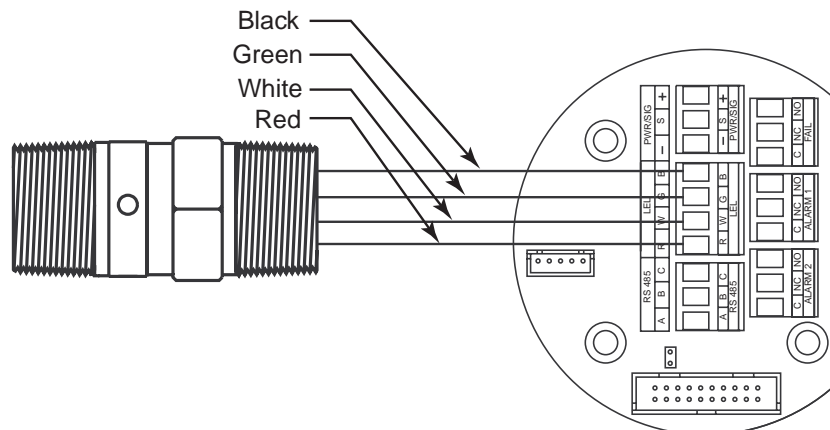
1. Remove the junction box cover.
2. Grasp the control PCB by its edges.
3. Gently pull until the control PCB is pulled away from the banana jacks. Take care not to pull too hard and damage the cable which connects the control and terminal PCB's.
4. Let the control PCB hang by the cable. The terminal strips are now visible on the terminal PCB. The control PCB may be left hanging while wiring is done. If desired, the control PCB may be disconnected from the cable and set aside while wiring.
5. The detector leads are factory wired. Verify that the detector leads are wired to the detector terminal strip as shown in the applicable figure below:

- Catalytic LEL/Combustible IR/CO<sub>2</sub> Detectors

The wiring for these types of detectors is the same. Red wire to terminal labelled LEL R, white wire to terminal labelled LEL W, green wire to terminal labelled LEL G, black wire to terminal labelled LEL B.

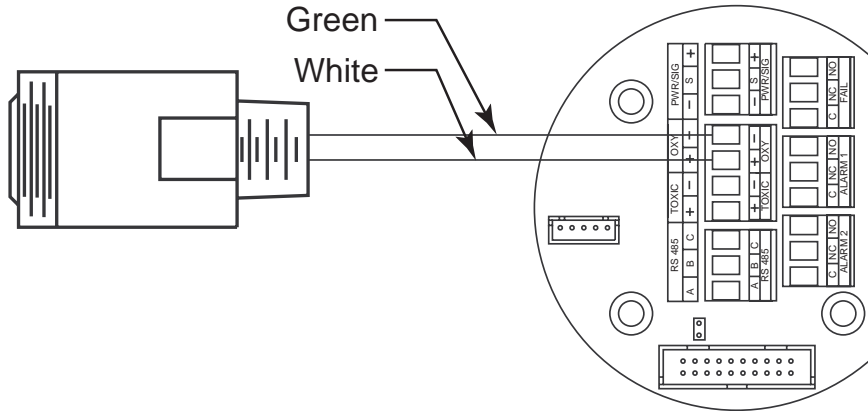


**Figure 14: Catalytic LEL Detector Wiring**

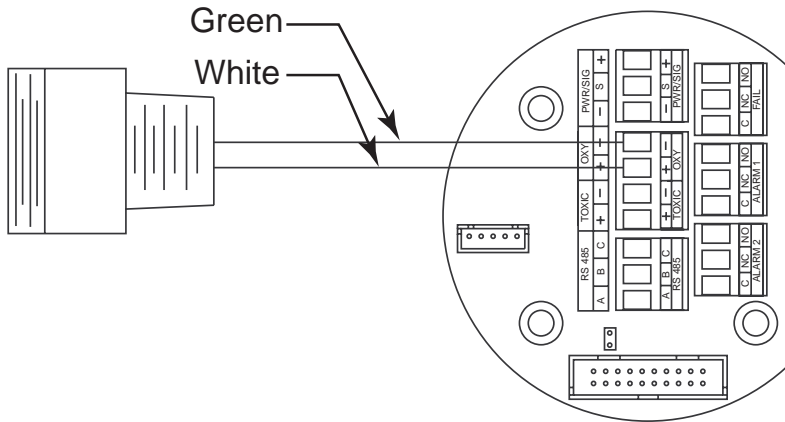


**Figure 15: Combustible IR/CO<sub>2</sub> Detector Wiring**

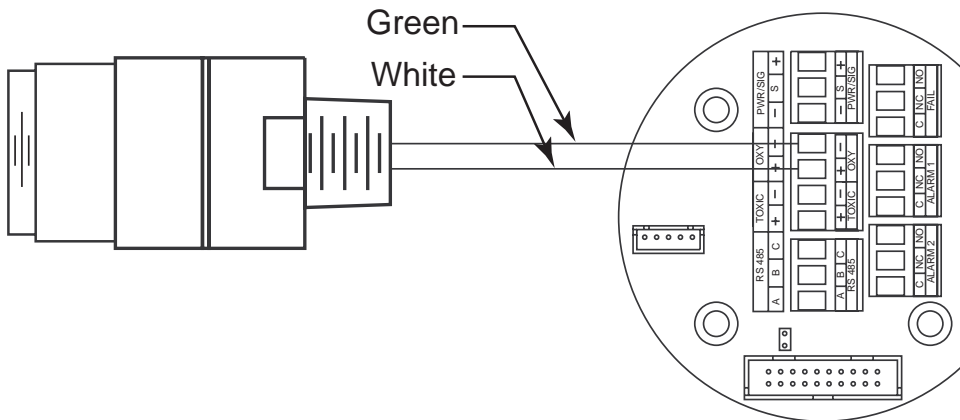
- Oxygen Detector, Partial Pressure, Capillary Type, and CSA Capillary Type  
The wiring for all the oxygen detectors is the same. White wire to terminal labelled OXY +, green wire to terminal labelled OXY -.



**Figure 16: Partial Pressure Oxygen Detector Wiring**



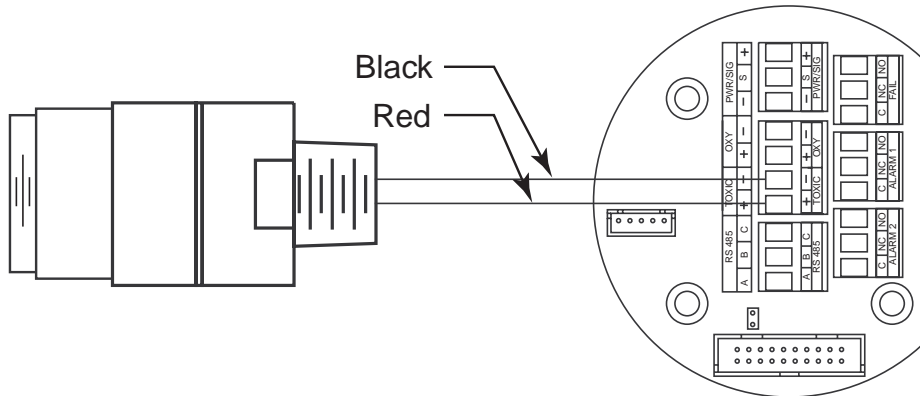
**Figure 17: Capillary Oxygen Detector Wiring**



**Figure 18: CSA Capillary Type Oxygen Detector Wiring**

- CO or H<sub>2</sub>S gas detector.

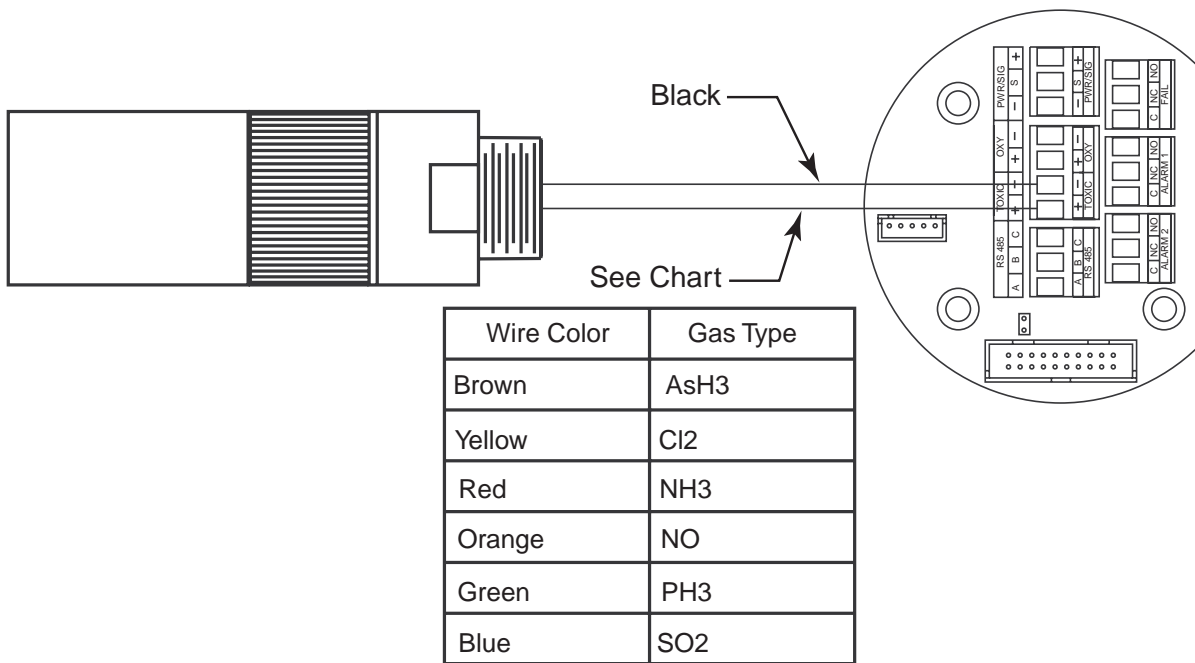
Red wire to terminal labeled TOXIC +, black wire to terminal labelled TOXIC -.



**Figure 19: H2S/CO Detector Wiring**

- ESM-01 Toxic Detectors

The ESM-01 toxic detectors have one black wire and one color coded wire. Connect the color coded wire (see chart below) to the terminal labelled TOXIC + and the black wire to the terminal labelled TOXIC -.



**Figure 20: ESM-01 Toxic Detector Wiring**

6. To gain access to a plug-in terminal strip for wiring, pull it out of its socket by grasping the wall between two terminal positions with needle nose pliers and pulling. Be careful not to exert too much force on the wall to avoid damage to the terminal strip. The detector terminal strip and the alarm 1 relay terminal strip may be removed by grasping them with your fingers if the adjacent terminal strips have been removed.

---

**WARNING:** *If the M2 is installed in a hazardous location, use appropriately rated conduit, conduit fittings, and appropriate construction technique that complies with the local electrical code.*  
*In addition, use appropriately rated conduit, conduit fittings, and appropriate construction technique to maintain the NEMA 4 environmental rating of the junction box and avoid water entering the junction box at the conduit hubs.*

---

7. Guide multi conductor shielded cable or cables or wires in conduit through the top conduit hub of the junction box. The number of cables or wires needed will depend on whether the M2 is wired to a gas monitoring controller or just to power, whether any relays are used, and whether the Modbus output is used. Use the following recommendations to determine how to wire the M2:
  - If Modbus connections will not be used and only the PWR/SIG connections will be used, use a two or three conductor shielded cable or two or three wires in conduit for connections to the power/signal terminal strip depending on whether or not the signal (S) terminal is used. The S terminal has a 4 - 20 mA output, but if you do not need to monitor this signal and do not connect to the S terminal to access this signal, the M2 will still function completely.

**Table 4: Wire Size for PWR/SIG Connections**

<b>Max Distance to Controller w/ 18 Gauge Wire</b>	<b>Max Distance to Controller w/16 Gauge Wire</b>	<b>Max Distance to Controller w/14 Gauge Wire</b>
2,500 ft.	5,000 ft.	8,000 ft.

- If the PWR/SIG connections and one or more relays are used, route the connections to the M2 in conduit. Use shielded cable in the conduit for the PWR/SIG connections and unshielded cable or individual wires for the relay connections. Make sure any wire or cable used for relay wiring is appropriately rated for the power that it will carry.

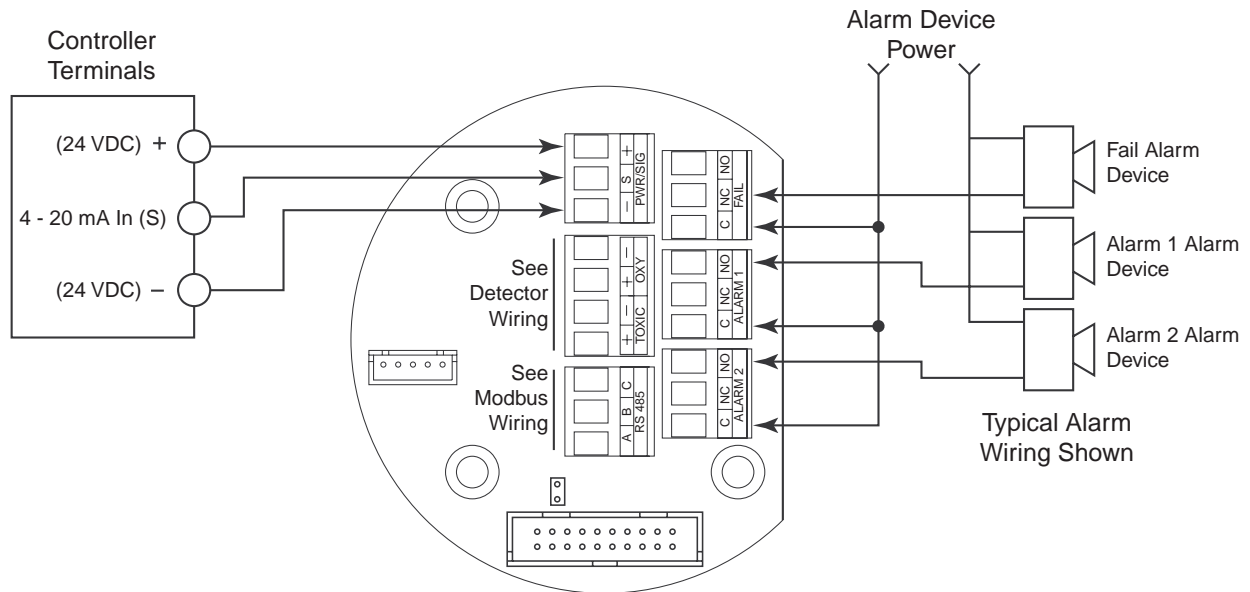
---

**NOTE:** If shielded cable is used for the PWR/SIG connections, leave the cable shield's drain wire insulated and disconnected at the M2. You will connect the opposite end of the cable's drain wire at the controller or device.

---

- If the M2 will be wired into a Modbus network, see "Chapter 8: RS-485 Modbus Output" on page 52.

See Figure 21 below for field wiring connections to the M2.



**Figure 21:Wiring the M2 to a Controller and Alarm Devices**

8. Re-install the control PCB (and ribbon cable if necessary). Be sure the ribbon cable is routed down below the control PCB so it will not be damaged by the cover when it is screwed back on.
9. Secure the junction box cover to the junction box.
10. Make controller, device, and relay connections as appropriate. If shielded cable is used for the PWR/SIG connections, connect the cable shield's drain wire to an available chassis ground at the gas monitoring controller, recording device, or programmable controller.

---

## Start Up

### Introducing Incoming Power

1. Complete the installation procedures described earlier in this manual.
2. Verify that all wiring connections are correct and secure.
3. Turn on the incoming power.
4. If necessary, turn on the controller or other monitoring device that is connected to the M2.
5. The LCD display will indicate the firmware version when the M2 is first powered up and will then count down a one minute warm-up period before normal operation begins. During normal operation, the display will indicate the target gas and current gas reading. Verify that the display is indicating the target gas and current gas reading after the warm-up period is complete and normal operation begins.

METHANE 0 %LEL
-------------------

---

**NOTE:** Allow the M2's detector to warm up for 15 minutes before you continue with the next section, "Adjusting the Fresh Air Reading."

---

### Adjusting the Fresh Air Reading

When the M2 is shipped from RKI Instruments, Inc. it is factory calibrated. If a full calibration is desired at startup, See "Calibration, Combustible Gas, CO<sub>2</sub>, and Toxic Versions" on page 42 or "Calibration, Oxygen Version" on page 46.

Verify that the M2 is in a fresh air environment (environment known to be free of the target gas and combustible or toxic gas vapors and of normal oxygen content, 20.9%).

---

**CAUTION:** *If you suspect the presence of combustible gas, CO<sub>2</sub>, toxic gas, or that the oxygen content is not normal in the monitoring environment, use the calibration kit and the zero air calibration cylinder to introduce "fresh air" to the detector and verify an accurate fresh air setting. See the "Calibration, Combustible Gas, CO<sub>2</sub>, and Toxic Versions" on page 42 or "Calibration, Oxygen Version" on page 46 for instructions on how to use a zero air cylinder when performing a fresh air adjustment.*

---

### Non-Intrusive Fresh Air Signal Adjustment

If the M2 is installed in a classified area and non-intrusive zero adjustment is required, follow the instructions below, **but do not remove the junction box cover**. Use the magnetic wand accessory to actuate the magnetic switches instead of pushing the control switch buttons. To actuate a magnetic switch and perform the same operation as pressing a control switch button, touch the magnet in the end of the magnetic wand to the M2's glass cover directly over the magnetic switch you wish to actuate. Touching the glass and removing the wand is the same as pressing and releasing a button. Touching the glass and keeping the wand in place is the same as pressing and holding a button.

---

**WARNING:** *The M2 is not an active gas monitoring device during the fresh air adjustment procedure. The 4-20 mA output signal will “freeze” at 3.5 mA for a toxic, combustible gas, or CO<sub>2</sub> M2, or at 17.4 mA for an oxygen M2, and all relays will remain in their non-alarm state while the M2 is in Calibration Mode. The output signal will not indicate current readings and the relays will not resume operating normally until the M2 is in normal operation again.*

---

---

**NOTE:** While in the calibration program, if there is no switch activity for the calibration time-out period the unit will return to normal operation. The factory set time-out is 15 minutes. If you want a different time-out period, see “Viewing & Changing M2 Parameters” on page 32 for instructions to change the calibration time-out.

---

### ***Combustible Gas, CO<sub>2</sub>, and Toxic Versions, Adjusting the Fresh Air Reading***

1. While in normal operation, press and hold the UP/YES button for 5 seconds to enter Calibration Mode. Release the button when the following screen appears.

Calib? YES/NO
------------------

2. Press and release the UP/YES button to continue. The display will indicate the target gas and **CAL Mode** for a few seconds before showing **FreshAir Adjust?**.
3. Press and release the UP/YES button. **ENTER** will alternate with **FreshAir** on the top display line and the current gas reading will be on the bottom display line.
4. Press and release the ENTER button. The M2 will perform a zero operation and the display will indicate **SPAN w/Cal Gas?**.
5. Press and release the DOWN/NO button. The display will indicate **Leaving CAL Mode** and the M2 will return to normal operation.

### ***Oxygen Version, Adjusting the Fresh Air Reading***

1. While in normal operation, press and hold the UP/YES button for 5 seconds to enter Calibration Mode. Release the button when the following screen appears.

Calib? YES/NO
------------------

2. Press and release the UP/YES button to continue. The display will indicate **OXYGEN CAL Mode** for a few seconds before showing **FreshAir Adjust?**.
3. Press and release the UP/YES button. **ENTER** will alternate with **FreshAir** on the top display line and the current oxygen reading will be on the bottom display line.
4. Press and release the ENTER button. The M2 will perform a span operation and then display will indicate **ZERO w/Cal Gas?**.
5. Press and release the DOWN/NO button. The display will indicate **Leaving CAL Mode** and the M2 will return to normal operation.

# Chapter 4: Operation

---

## Overview

This chapter describes the M2 in normal operation. This chapter also describes the M2 in alarm 1, alarm 2, and fail conditions and suggests response to these conditions.

---

## Normal Operation

Normal operation is defined as follows:

- The start-up procedure is complete.
- The M2 is not indicating an alarm 1, alarm 2, or fail condition.
- The M2 is not in Calibration, Configuration, or Gas Type modes.

During normal operation, the M2 simultaneously displays the current gas reading, unit of measure, and target gas. The example below illustrates a typical combustible gas M2.

METHANE 0 %LEL
-------------------

---

## Information Screen

The Information Screen displays the M2's operating voltage and firmware and hardware information. To display the Information Screen, do the following:

1. Press and hold the DOWN/NO button for 3 seconds. The Information Screen will appear.

24.2V v4.5L 2A
-------------------

2. Continue holding the DOWN/NO button to keep the Information Screen on the display. The top line indicates the operating voltage that is connected to the M2. The second line indicates the firmware that is running, version 4.4L in this example, and the M2's hardware version, version 2A in this example. This information may be useful if you need to contact the factory with questions about the M2.
3. Release the DOWN/NO button when you are done viewing the Information Screen. The display will return to the normal operation screen within a couple of seconds.

---

## 4 - 20 mA Signal Output Operation

The output at the S terminal of the power/signal terminal strip is a 4 - 20 mA signal that corresponds to the detection range of the M2. During normal operation, this signal tracks the gas concentration on the LCD.

There are several circumstances where the signal output will not track the display reading but will behave as follows:

- When the M2 is in its warm-up period, the signal output will be fixed at 4 mA (zero) for all gas types except oxygen. For oxygen types, the output will be fixed at 17.4 mA (20.9% oxygen) while the M2 is in warm-up.
- When the M2's gas type is changed, the M2 will enter Configuration Mode for you to verify the parameter settings. When you exit Configuration Mode, the display will indicate **NEEDS CALIBRATION** and will continue to indicate this until Calibration Mode is entered and a calibration is performed. In this situation, the signal output will be fixed at 3.5 mA for LEL and toxic versions and 17.4 mA for oxygen versions from the time Gas Type Mode is entered until the M2 is calibrated and returns to normal operation.
- If you enter Calibration Mode, Configuration Mode, Gas Type Mode, or Modbus Mode, the signal output will be fixed at 3.5 mA for combustible gas, CO<sub>2</sub>, and toxic versions and 17.4 mA for oxygen versions until the M2 returns to normal operation.
- If the M2's input power decreases below 18.5 volts so that the M2 is in a low power alarm, the signal output is fixed below 2.4 mA until the low power alarm is cleared.
- If the M2 goes into a fail condition, the signal output is fixed below 2.4 mA until the fail alarm is cleared.

---

## Alarm Indications

---

**NOTE:** The M2 includes alarm on and alarm off delay settings for alarm 1 and alarm 2. The alarm indications described in this section operate according to the factory set alarm settings. See Table 6 on page 33 for all the factory settings.

---

**Table 5: Visual and Audible Alarm Indications**

Condition	Cause	Visual Indication(s)
Alarm 1 <sup>1</sup>	Increasing (decreasing for O <sub>2</sub> ) gas reading at or above the alarm 1 setpoint	<ul style="list-style-type: none"><li>• A1 LED is on</li><li>• Gas reading alternates with <b>ALARM-1</b> message</li></ul>
Alarm 2 <sup>1</sup>	Increasing gas reading at or above the alarm 2 setpoint	<ul style="list-style-type: none"><li>• A2 LED is on</li><li>• Gas reading alternates with <b>ALARM-2</b> message</li></ul>
Fail	<ul style="list-style-type: none"><li>• Disconnected or misconnected detector wiring</li><li>• Display reading at -10% of full scale or lower</li><li>• Defective components</li></ul>	<ul style="list-style-type: none"><li>• F LED is on</li><li>• <b>FAIL</b> message replaces gas reading</li></ul>

**Table 5: Visual and Audible Alarm Indications**

Condition	Cause	Visual Indication(s)
Low Power	DC power source less than 18.5 volts.	<ul style="list-style-type: none"> <li>• F LED is on</li> <li>• <b>LowPower</b> message and actual voltage of incoming DC power</li> </ul>
<p>* <sup>1</sup><i>If the M2 is in both an alarm 1 and an alarm 2 condition, both alarm LEDs are on and the display alternates between the gas reading and the ALMS 1&amp;2 message.</i></p>		

---

**NOTE:** You can select normally energized (N. EN) or normally de-energized (N. DE-EN) alarm 1 and alarm 2 relay settings in Configuration Mode. The following sections describe the standard factory setting for these relays which is N. DE-EN.

The fail relay is factory set as N. EN and is not user-adjustable.

---

## Alarm 1 Condition

### *Alarm 1 condition indications*

When the gas reading reaches the alarm 1 setpoint, the M2 senses an alarm 1 condition. The M2 alerts you to an alarm 1 condition as follows:

- The A1 LED turns on.
- The gas reading alternates with the **ALARM-1** message.
- The alarm 1 relay energizes.

### *Responding to an alarm 1 condition*

1. Follow your established procedure for a low level combustible or toxic gas condition or a decreasing oxygen concentration condition.
2. After the gas reading falls below (above for oxygen) the alarm 1 setpoint, press the ENTER button to reset the alarm 1 circuit. Resetting the alarm 1 circuit turns off the A1 LED, resets the LCD, and de-energizes the alarm 1 relay.

---

**NOTE:** If the ENTER button is pressed while the M2 is in an alarm 1 condition, the A1 LED will flash but all other indications will remain unchanged.

You cannot de-energize the alarm 1 relay until the gas reading falls below (above for oxygen) the alarm 1 setpoint.

---

## Alarm 2 Condition

### *Alarm 2 condition indications*

When the gas reading reaches the alarm 2 setpoint, the M2 senses an alarm 2 condition. The M2 alerts you to an alarm 2 condition as follows:

- The A2 LED turns on.
- The gas reading alternates with the **ALARM-2** message.
- The alarm 2 relay energizes.

---

**NOTE:** If the M2 is in both an alarm 1 and alarm 2 condition, both the A1 and A2 LEDs will be on, the gas reading will alternate with the **ALMS 1&2** message, and both alarm relays will energize.

---

### ***Responding to an alarm 2 condition***

1. Follow your established procedure for a high level combustible or toxic gas condition or an increasing oxygen concentration condition.
2. After the gas reading falls below the alarm 2 setpoint, press the ENTER button to reset the alarm circuit. Resetting the alarm circuit turns off the A2 light, resets the LCD, and de-energizes the alarm 2 relay.

---

**NOTE:** If the ENTER button is pressed while the M2 is in an alarm 2 condition, the A2 LED will flash but all other indications will remain unchanged.

You cannot de-energize the alarm 2 relay until the gas reading falls below the alarm 2 setpoint.

---

## **Fail Condition**

### ***Fail condition indications***

The M2 indicates a fail condition for any of the following:

- The detector wiring is disconnected or incorrectly connected.
- The display reading is -10% of full scale or lower.

When the M2 senses a fail condition, it alerts you as follows:

- The F LED turns on.
- The gas reading is replaced by the **FAIL** message.
- The fail relay de-energizes.

### ***Responding to a fail condition***

1. Verify that the detector wiring is correctly and securely connected.
2. If the M2 has a replaceable plug-in sensor, verify that the replaceable plug-in sensor in the detector housing is properly installed.

## **Low Power Alarm**

### ***Low power alarm indications***

The M2 senses a low power condition when the DC power source is 18.5 volts or less.

---

**WARNING:** *While in a low power condition, the M2 is not an active gas monitor.*

---

When the M2 senses a low power condition, it alerts you as follows:

- The F LED turns on.
- The message **LowPower** is indicated on the top line of the LCD and the input voltage is displayed on the bottom line of the LCD.
- The fail relay de-energizes.

---

**NOTE:** The low power alarm cannot be cleared using the ENTER button.

---

When the increases voltage increases to 19.0 volts, the low power alarm is cleared and the M2 will begin its warm-up sequence.

***Responding to a low power condition***

1. Determine and correct the cause of the low power condition.
2. When the input power increases above 19.0 volts, the M2 will begin its warm-up sequence.
3. Verify that the M2 enters normal operation after its warm-up sequence. If necessary, perform a fresh air adjustment. See “Adjusting the Fresh Air Reading” on page 25.

# Chapter 5: Configuration Mode

---

## Overview

This chapter describes how to view and change M2 parameters using Configuration Mode. It is accessed using the program buttons.

Configuration Mode includes a 5-minute time-out feature. If you do not press a control button for 5 minutes, the M2 automatically returns to normal operation.

---

**NOTE:** If the M2 returns to normal operation because of a time-out, it enters a warm-up period just as it does when it is first turned on.

If you are installing a new M2, it has been setup at the factory. Use Configuration Mode only if you want to change the M2's setup. If you want to change the detector type see "Chapter 6: Gas Type Mode" on page 35.

---

---

## Viewing & Changing M2 Parameters

1. While in normal operation, simultaneously press and hold the UP/YES and ENTER buttons for 5 seconds to enter Configuration Mode. Release the buttons when the following screen appears.

Enter  
Config?

2. If you want to exit Configuration Mode, press and release the DOWN/NO button and the M2 will return to normal operation.

If you want to continue in Configuration Mode, press and release the UP/YES button. The target gas and the full scale will be displayed for a few seconds before the first adjustable parameter, the alarm 1 setpoint, is displayed.

3. If you want to change the currently displayed parameter, use the UP/YES and DOWN/NO buttons to adjust it to the desired setting, then press ENTER to continue to the next parameter.

If the currently displayed parameter is OK, press the ENTER button to proceed to the next parameter.

Table 6 lists the M2 parameters you can set. Table 6 also lists the factory set value for each parameter.

**Table 6: Configuration Parameters**

<b>Parameter (Factory Set Value)</b>	<b>Description</b>
ALARM-1 (level) (See "M2 Specifications" on page 6)	The gas reading at which the M2 initiates an alarm 1 condition.
ALARM-1 (activation) (Decrease for oxygen M2, Increase for all other types)	Indicates if the alarm 1 circuit is activated by gas readings increasing ( <b>Increase</b> ) or decreasing ( <b>Decrease</b> ) to the ALARM-1 Level.
ALARM-1 (relay action) (N. DE-EN)	If set as <b>N. DE-EN</b> , the alarm 1 relay is de-energized in normal operation and energizes when an alarm 1 condition is initiated. If set as <b>N. EN</b> , the alarm 1 relay is energized in normal operation and de-energizes when an alarm 1 condition is initiated.
ALARM-1 (relay reset) (LATCH)	If set as <b>LATCH</b> , you must press the ENTER button to reset the alarm 1 circuit after the alarm 1 condition passes. If set as <b>SELF-RST</b> , the M2 automatically resets the alarm 1 circuit after the alarm 1 condition passes.
A1 OnDy (alarm 1 on delay) (1 secs)	The amount of time the M2 delays activation of the alarm 1 circuit once an alarm 1 condition is initiated. It is settable in 1 second increments from 0 - 60 seconds, in 1 minute increments from 1 - 15 minutes, and in 15 minute increments from 15 - 60 minutes.
A1 OffDy (alarm 1 off delay) (0 sec.)	The amount of time the M2 delays turning off the alarm 1 circuit once an alarm 1 condition passes. This parameter appears only if the alarm 1 relay reset setting is set to <b>SELF--RST</b> . It is settable in 1 second increments from 0 - 60 seconds, in 1 minute increments from 1 - 15 minutes, and in 15 minute increments from 15 - 60 minutes.
ALARM-2 (level) (See "M2 Specifications" on page 6)	The gas reading at which the M2 initiates an alarm 2 condition.
ALARM-2 (activation) ( Increase for all types)	Indicates if the alarm 2 circuit is activated by gas readings increasing ( <b>Increase</b> ) or decreasing ( <b>Decrease</b> ) to the ALARM-1 Level.
ALARM-2 (relay action) (N. DE-EN)	If set as <b>N. DE-EN</b> , the alarm 2 relay is de-energized in normal operation and energizes when an alarm 2 condition is initiated. If set as <b>N. EN</b> , the alarm 2 relay is energized in normal operation and de-energizes when an alarm 2 condition is initiated.
ALARM-2 (relay reset) (LATCH)	If set as <b>LATCH</b> , you must press the ENTER button to reset the alarm 2 circuit after the alarm 2 condition passes. If set as <b>SELF-RST</b> , the M2 automatically resets the alarm 2 circuit after the alarm 2 condition passes.
A2 OnDy (alarm 2 on delay) (1 secs)	The amount of time the M2 delays activation of the alarm 2 circuit once an alarm 2 condition is initiated. It is settable in 1 second increments from 0 - 60 seconds, in 1 minute increments from 1 - 15 minutes, and in 15 minute increments from 15 - 60 minutes.
A2 OffDy (alarm 2 off delay) (0 sec.)	The amount of time the M2 delays turning off the alarm 2 circuit once an alarm 2 condition passes. This parameter appears only if the alarm 2 relay reset setting is set to <b>SELF-RST</b> . It is settable in 1 second increments from 0 - 60 seconds, in 1 minute increments from 1 - 15 minutes, and in 15 minute increments from 15 - 60 minutes.

**Table 6: Configuration Parameters (Continued)**

<b>Parameter (Factory Set Value)</b>	<b>Description</b>
ZeroSupp (0.5% <b>oxygen</b> for oxygen types, 2% of the <b>detection range</b> in terms of the detection units for all other types)	The zero suppression feature helps prevent “jumpy” readings near the fresh air reading. For example, if the zero suppression setting for a combustible LEL detector is <b>2.0% LEL</b> , the M2 will display a reading of 0% LEL for gas readings from -2% LEL to 2% LEL. It is settable from 0 to 6% of the detection range.
FILTER (5 secs)	The filter feature helps “smooth out” jumpy or noisy signals from the detector. You can set the filter from 0 seconds to 60 seconds in 5 seconds increments. The displayed gas reading is the average reading over the previous time period defined by the filter setting. So if the filter is set to 5 seconds, the displayed gas reading is the average over the past 5 seconds.
CAL Time (15 mins)	The calibration time-out sets the amount of time after the last button push while in Calibration Mode that the M2 will wait before returning to normal operation. If the calibration time-out is set to <b>15 mins</b> , then M2 will return to normal operation automatically 15 minutes after the last button push.

4. When you have scrolled through all the adjustable parameters, **SAVE IT? YES/NO** appears on the display.
5. If you do not wish to save the adjustments and want to exit Configuration Mode, press and release the DOWN/NO button. The **DO OVER? YES/NO** message will display. Press and release the DOWN/NO button. The **ABORT? YES/NO** message will display. Press the UP/YES button to return to normal operation.

If you wish to change some of the adjustments made, press and release the DOWN/NO button. The **DO OVER? YES/NO** message will display. Press and release the UP/YES button. The **Re-do Config** message will display and the M2 will return to the first adjustable parameter. Go back to step 3 and continue.

If you wish to save the adjustments made, press and release the UP/YES button. **Config Saved** is indicated on the display for a few seconds and the M2 returns to normal operation.

# Chapter 6: Gas Type Mode

---

## Overview

This chapter describes how to use Gas Type Mode to select the M2's gas type. The gas type determines the target gas and detection range. The combustible gas/CO<sub>2</sub> and toxic/oxygen M2s have a different terminal PCB and run on different firmware. Your M2 will only have gas type choices available that it can support.

Gas Type Mode includes a 5-minute time-out feature. If you do not press a button for 5 minutes, the M2 automatically returns to normal operation.

---

**NOTE:** If the M2 enters normal operation because of a program time-out, it enters a warm-up period just as it does when it is first turned on.

---

---

## Selecting the Gas Type

1. While in normal operation or during the warm-up sequence, press and hold the UP/YES and DOWN/NO buttons for five seconds. Release them when the following screen appears.

Select  
GasType?

2. If you want to exit Gas Type Mode, press and release the DOWN/NO button. The display will indicate **NO CHANGE** and the M2 will return to normal operation.  
If you want to continue in Gas Type Mode, press and release the UP/YES button. The top display line will indicate **GasType?** and the bottom display line will indicate the target gas choice.
3. Use the UP/YES or DOWN/NO button to scroll through the choices of target gas. Table 7 and Table 8 below list the choices of target gas for the M2.

**Table 7: Combustible Gas/CO<sub>2</sub> Gas Types**

Gas Type Choices	Detection Range
HC	0 - 100% LEL
iBUTANE	0 - 100% LEL
PROPANE	0 - 100% LEL
HEXANE	0 - 100% LEL
HYDROGEN	0 - 100% LEL
METHANE	0 - 100% Volume
METHANE	0 - 100% LEL

**Table 7: Combustible Gas/CO<sub>2</sub> Gas Types**

<b>Gas Type Choices</b>	<b>Detection Range</b>
CO <sub>2</sub>	0 - 5,000 ppm
CO <sub>2</sub>	0 - 2,000 ppm
CO <sub>2</sub>	0 - 5% volume

**Table 8: Toxic/Oxygen Gas Types**

<b>Gas Type Choices</b>	<b>Detection Range</b>
H <sub>2</sub> S	0 - 100 ppm
CO	0 - 300 ppm
OXYGEN	0 - 25.0%
SiH <sub>4</sub>	0 - 15.0 ppm
Si <sub>2</sub> H <sub>6</sub>	0 - 15.0 ppm
PH <sub>3</sub>	0 - 1.00 ppm
O <sub>3</sub>	0 - 1.00 ppm
NO	0 - 100 ppm
HCN	0 - 30.0 ppm
HCL	15.0 ppm
H <sub>2</sub> SE	5.00 ppm
GEH <sub>4</sub>	1.50 ppm
F <sub>2</sub>	0 - 3.00 ppm
CLO <sub>2</sub>	0 - 1.00 ppm
B <sub>2</sub> H <sub>6</sub>	0 - 5.00 ppm
ASH <sub>3</sub>	0 - 1.50 ppm
SO <sub>2</sub>	0 - 6.00 ppm
NH <sub>3</sub>	0 - 75.0 ppm
CL <sub>2</sub>	0 - 3.00 ppm
NO	0 - 100 ppm

---

**NOTE:** Consult factory for availability of detectors for toxic M2 types not listed in “M2 Specifications” on page 6.

---

4. When the desired target gas is on the display, press and release the ENTER button. The display will ask **SAVE IT? YES/NO**.
5. To discard the gas type change, press and release the DOWN/NO button. The display will ask **DO OVER? YES/NO**. Press the DOWN/NO button. The display will ask **ABORT? YES/NO**. Press the UP/YES button. The M2 will return to normal operating without changing the gas type.  
  
To save the gas type, press and release the UP/YES button. The display will indicate **Gas Type Updated**, the display will indicate the target gas and the detection range for a few seconds, and then the M2 will enter Configuration Mode automatically so that the parameter settings in Configuration Mode can be verified or changed.
6. While in Configuration Mode press and release the ENTER button to accept the displayed parameter setting and move to the next one. Use the UP/YES and DOWN/NO buttons to adjust a setting. See “Chapter 5: Configuration Mode” on page 32 for a complete description of Configuration Mode.
7. When you have reviewed and accepted the last item in Configuration Mode by pressing the ENTER button, display will ask **SAVE IT? YES/NO**.
8. To save the configuration settings, press and release the UP/YES button. The display will indicate **Config Saved** and the M2 will begin its warm-up sequence.  
  
To discard the settings and review them again, press the DOWN/NO button. The display will ask **DO OVER? YES/NO**. Press the UP/YES button and the display will indicate **Re-do Config**, then display the target gas and the detection range for a few seconds before returning to Configuration Mode. Repeat steps 6 - 8 until the settings are as desired.
9. After the M2 completes its warm-up sequence, the display will indicate **CAL NEEDED**. Since the gas type has been changed, a successful calibration must be performed before the M2 can enter normal operation.
10. Press and release the UP/YES button to enter Calibration Mode. Normally, you must hold the UP/YES button for 5 seconds to enter Calibration Mode, but since a calibration is required, only a momentary push is needed to enter Calibration Mode after changing the gas type.
11. See “Calibration, Combustible Gas, CO<sub>2</sub>, and Toxic Versions” on page 42 or “Calibration, Oxygen Version” on page 46 for calibration instructions.

---

**NOTE:** When calibrating an M2 after changing the gas type, the M2 will not ask if you want to calibrate, or whether you want to perform a fresh air adjustment, span adjustment or zero adjustment. Since a complete calibration is required, the calibration sequence will proceed without asking if you want to perform certain operations.

---

# Chapter 7: Maintenance

---

## Overview

This chapter describes procedures for performing preventive maintenance, troubleshooting, calibrating the M2, and replacing field replaceable parts. It includes separate procedures for calibrating the combustible gas/CO<sub>2</sub>/toxic and oxygen versions of the M2.

---

## Preventive Maintenance

This section describes a recommended preventive maintenance schedule to ensure the optimum performance of the M2. It includes daily, monthly, and quarterly procedures.

### Daily

Verify a display reading of zero (20.9% for an oxygen M2). Investigate significant changes in the reading.

### Monthly

This procedure describes a test to verify that the M2 responds properly to the target gas.

---

**NOTE:** Performing a response test on the M2 may cause alarms. If you do not want external alarms to actuate, disable any external alarms during the response test to avoid unwanted external alarm indications.

---

---

**NOTE:** The following procedure assumes the use of a calibration kit which includes a calibration gas cylinder, a fixed flow regulator with an on/off knob, a calibration cup for the detector, and a short piece of sample tubing to connect the regulator to the calibration cup.

---

1. Disable all external alarms if external alarm indications are not desired during the response test.
2. Connect the calibration kit sample tubing to the calibration cup hose barb.
3. Screw the calibration cup onto the detector.

---

**NOTE:** For an ESM-01 detector, you must unscrew the removable splashguard from the detector housing cap so you can push the appropriate calibration cup onto the ESM-01 sensor. Make sure to use the correct calibration cup for the sensor being used. There is a Cl<sub>2</sub> type calibration cup for a Cl<sub>2</sub> sensor, an NH<sub>3</sub> type calibration cup for an NH<sub>3</sub> sensor, and a general type (usually labelled SO<sub>2</sub>) calibration cup for all other ESM-01 sensors.

---

4. Connect the fixed flow regulator to the calibration cup using the sample tubing.

---

**NOTE:** When applying gas to an NH<sub>3</sub> ESM-01, the 0.25 LPM flowrate regulator must be used. All other M2s require a 0.5 LPM flowrate regulator.

---

5. Screw the calibration gas cylinder into (onto for an H<sub>2</sub>S cylinder) the fixed flow regulator.
6. Turn the regulator knob counterclockwise to open the regulator.
7. Allow calibration gas to flow for one minute.
8. Verify that the display reading is within  $\pm 20\%$  of the gas concentration.

---

**NOTE:** If the reading is not within  $\pm 20\%$  of the gas concentration, calibrate the M2 as described in “Calibration, Combustible Gas, CO<sub>2</sub>, and Toxic Versions” on page 42 or “Calibration, Oxygen Version” on page 46.

---

9. Turn the regulator knob clockwise to close the regulator.
10. Unscrew the calibration gas cylinder from the fixed flow regulator and unscrew the calibration cup from the detector.  
For an ESM-01 detector, pull the calibration cup off the ESM-01 sensor and screw the splashguard back onto the detector housing cap.
11. If external alarms have been disabled, enable them when the display returns to a normal fresh air reading.
12. Store the components of the calibration kit in a safe place.

### **Quarterly**

Calibrate M2s that do not have an IR detector as described in “Calibration, Combustible Gas, CO<sub>2</sub>, and Toxic Versions” on page 42 or “Calibration, Oxygen Version” on page 46. See “Calibration Frequency” on page 42 for a discussion of calibration frequency guidelines.

### **Bianually**

Calibrate M2s that have an IR detector as described in “Calibration, Combustible Gas, CO<sub>2</sub>, and Toxic Versions” on page 42. See “Calibration Frequency” on page 42 for a discussion of calibration frequency guidelines.

## Troubleshooting

The troubleshooting guide describes symptoms, probable causes, and recommended action for problems you may encounter with the M2

**NOTE:** This troubleshooting guide describes M2 problems only. If the M2 is connected to a controller, see the controller operator’s manual for problems you may encounter with the controller.

**Table 9: Troubleshooting the Combustible Gas Detector**

Condition	Symptom(s)	Probable Causes	Recommended Action
No Power	The display backlight is off and the display screen is blank.	The power wiring is disconnected or misconnected. The display cable is disconnected or misconnected.	Verify that the wiring to the power source or controller is correct and secure. Verify that the ribbon cable connecting the terminal PCB to the control PCB is securely installed. This ribbon cable plugs into a connector on the top edge of the control PCB and on the bottom of the terminal PCB. If the power difficulties continue, contact RKI for further instruction.
Frequent or Suspect Alarms	The M2 alerts you to frequent or suspect alarms while the fresh air readings remain on zero (20.9 for oxygen).	The M2 is experiencing false readings due to RFI or EMI. The detector wiring is disconnected, misconnected, or intermittent.	Verify that the M2 wiring is properly shielded. See “Wiring the M2 Transmitter” on page 20. Verify that the detector wiring is correct and secure. Increase the alarm on delay setting in Configuration Mode. If the frequent or suspect alarm difficulties continue, contact RKI for further instruction.
Flickering Display	The display reading flickers often.	The M2 is experiencing false readings due to RFI or EMI. The noise filter setting is too low. The zero suppression setting is too low. The display screen is malfunctioning.	Verify that the M2 wiring is properly shielded. See “Wiring the M2 Transmitter” on page 20. Verify that the detector wiring is correct and secure. Increase the filter setting in Configuration Mode. Increase the zero suppression setting in Configuration Mode. If the display difficulties continue, contact RKI for further instruction.

Table 9: Troubleshooting the Combustible Gas Detector (Continued)

Condition	Symptom(s)	Probable Causes	Recommended Action
Fail Condition	<ul style="list-style-type: none"> <li>• M2 indicates a fail condition.</li> <li>• Controller indicates a fail condition</li> </ul>	<ul style="list-style-type: none"> <li>• The detector wiring to the terminal PCB is disconnected or misconnected.</li> <li>• The wiring from the M2 to the controller is disconnected or misconnected.</li> <li>• The detector fresh air signal is low enough to cause a fail condition.</li> <li>• The detector is malfunctioning.</li> <li>• The terminal or display PCB is malfunctioning.</li> </ul>	<ol style="list-style-type: none"> <li>1. Verify that the detector wiring is correct and secure.</li> <li>2. Verify that the wiring between the M2 and the controller is correct and secure.</li> <li>3. Calibrate the M2.</li> <li>4. If the fail condition continues, replace the detector.</li> <li>5. If the fail condition continues, contact RKI for further instruction.</li> </ol>
Slow or No Response/ Difficult or Unable to Calibrate	<ul style="list-style-type: none"> <li>• M2 responds slowly or does not respond to response test.</li> <li>• Unable to successfully set the fresh air or span (zero for oxygen) reading during calibration.</li> <li>• M2 requires frequent calibration.</li> </ul> <p><i>Note: See "Calibration Frequency" on page 42 for calibration frequency guidelines.</i></p>	<ul style="list-style-type: none"> <li>• The calibration cylinder is low, out-dated, or defective.</li> <li>• The detector is malfunctioning.</li> <li>• The terminal PCB is malfunctioning.</li> </ul>	<ol style="list-style-type: none"> <li>1. Verify that the calibration cylinder contains an adequate supply of a fresh test sample.</li> <li>2. If the calibration/response difficulties continue, replace the detector.</li> <li>3. If the calibration/response difficulties continue, contact RKI for further instruction.</li> </ol>

---

## Calibration Frequency

Some M2s have IR (infrared) type detectors, such as an M2 for CO<sub>2</sub> or an LEL M2 with an IR detector. Most of the M2s do not have an IR detector. For example, an H<sub>2</sub>S M2 has an electrochemical detector and some of the combustible M2s use catalytic detectors. The M2s that use IR detectors typically need less frequent calibration as is discussed below. See Table 1, “M2 Specifications,” on page 6 to see which M2s are IR versions.

Although there is no particular calibration frequency that is correct for all applications, a calibration frequency of every 3 to 6 months for M2s that do not have an IR detector and every 6 to 12 months for M2s that have an IR detector is adequate for most M2 applications. Unless experience in a particular application dictates otherwise, RKI Instruments, Inc. recommends a calibration frequency of every 3 months for M2s that do not have an IR detector and every 6 months for M2s that have an IR detector.

If an application is not very demanding, for example detection in a clean, temperature controlled environment where the toxic or combustible target gas is not normally present, and calibration adjustments are minimal at calibration, then a calibration frequency of every 6 months for a non-IR M2 or 12 months for an IR M2 is adequate.

If an application is very demanding, for example if a combustible or toxic gas is present often and in significant concentrations or the environment is not well controlled, then more frequent calibration than every 3 months for non-IR M2 or every 6 months for an IR M2 may be necessary. For combustible gas detection with an M2 that uses a catalytic detector, if potential catalyst poisons are known or likely to be present, more frequent calibration than every 3 months will be necessary.

---

## Calibration, Combustible Gas, CO<sub>2</sub>, and Toxic Versions

This section describes how to calibrate the combustible gas, CO<sub>2</sub>, and toxic gas versions of the M2. It includes procedures to prepare for calibration, enter Calibration Mode, adjust the fresh air (zero) setting, adjust the span setting, and return to normal operation. See the next section, “Calibration, Oxygen Version” for instructions to calibrate an oxygen M2.

---

**WARNING:** *The M2 is not an active gas monitoring device during the calibration procedure. The 4-20 mA output signal will “freeze” at 3.5 mA and all relays will remain in their non-alarm state while the M2 is in Calibration Mode. The output signal will not indicate current readings and the relays will not resume operating normally until the M2 is in normal operation again.*

---

### Preparing for Calibration

---

**NOTE:** The following procedure assumes the use of a calibration kit which includes a calibration gas cylinder, a zero air cylinder, a fixed flow regulator with an on/off knob, a calibration cup for the appropriate sensor, and a short piece of sample tubing to connect the regulator to the calibration cup.

---

---

**NOTE:** While in the calibration program, if there is no switch activity for the calibration time-out period the unit will return to normal operation. See “Viewing & Changing M2 Parameters” on page 32 for instructions to set the calibration time-out.

---

---

**NOTE:** The following procedure assumes that the target gas is present in a high enough concentration to affect the fresh air (zero) reading. If a fresh air environment can be verified, applying zero air to the detector is not necessary when setting the zero (span for oxygen) reading.

---

1. Connect the calibration kit sample tubing to the calibration cup hose barb.
2. Screw the calibration cup onto the detector.

---

**NOTE:** For an ESM-01 detector, you must unscrew the removable splashguard from the detector housing cap so you can push the appropriate calibration cup onto the ESM-01 sensor. Make sure to use the correct calibration cup for the sensor being used. There is a Cl<sub>2</sub> type calibration cup for a Cl<sub>2</sub> sensor, an NH<sub>3</sub> type calibration cup for an NH<sub>3</sub> sensor, and a general type (usually labelled SO<sub>2</sub>) calibration cup for all other ESM-01 sensors.

---

3. Connect the fixed flow regulator to the calibration cup using the sample tubing.

---

**NOTE:** When calibrating an NH<sub>3</sub> ESM-01, the 0.25 LPM flowrate regulator must be used. All other M2s require a 0.5 LPM flowrate regulator.

---

### **Non-Intrusive Calibration**

If the M2 is installed in a classified area and non-intrusive calibration is required, follow the instructions below, but do not remove the junction box cover. Use the magnetic wand accessory to actuate the magnetic switches instead of pushing the control switch buttons. To actuate a magnetic switch and perform the same operation as pressing a control switch button, touch the magnet in the end of the magnetic wand to the M2's glass cover directly above the magnetic switch you wish to actuate. Touching the glass and removing the wand is the same as pressing and releasing a button. Touching the glass and keeping the wand in place is the same as pressing and holding a button.

### **Calibration Gas Response Memory Feature**

The M2 has the capability to “remember” the detector's response to the calibration gas after the gas is removed from the detector during the fresh air and span adjustment procedure. This feature enables one person to perform calibration if the detector is mounted remotely from the M2. When zero air is applied to the M2 during a fresh air adjustment, the M2 will freeze the display reading at the lowest response and the M2 will continue to display this reading and retain it in its memory until the fresh air adjustment procedure is completed. When calibration gas is applied to the M2 during a span adjustment, the M2 will freeze the display reading at the highest response to the calibration gas. The calibration gas can then be removed and the M2 will continue to display this reading and retain it in its memory until the span adjustment procedure is completed.

## Adjusting the Fresh Air Reading

1. While in normal operation, press and hold the UP/YES button for 5 seconds to enter Calibration Mode. Release the button when the following screen appears.

Calib? YES/NO
------------------

2. If you want to continue with calibration, press and release the UP/YES button. The display will indicate the target gas and **CAL Mode** for a few seconds before showing **FreshAir Adjust?**.

If you want to exit Calibration Mode, press and release the DOWN/NO button. The M2 will indicate **Leaving CAL Mode** and the M2 return to normal operation.

3. To continue with adjusting the fresh air reading, press and release the UP/YES button. **ENTER** will alternate with **FreshAir** on the top display line and the current gas reading will be on the bottom display line.

To skip adjusting the fresh air reading, press and release the DOWN/NO button. The display will indicate **SPAN w/Cal Gas?**. Skip to the next section, "Adjusting the Span Setting".

4. Screw the zero air cylinder into the fixed flow regulator.
5. Turn the regulator knob counterclockwise to open the regulator.
6. Allow zero air to flow for two minutes. If there was gas present causing a reading on the M2, the reading should decrease and stabilize after two minutes.
7. Turn the regulator knob clockwise to close the regulator.
8. Unscrew the zero air cylinder from the fixed flow regulator leaving the calibration cup on the detector. The M2 will continue to display the minimum gas response on the display and retain the response level in its memory.
9. Press and release the ENTER button. The M2 will perform a fresh air adjustment and the display will indicate **SPAN w/Cal Gas?**.

---

**NOTE:** If the fresh air adjustment fails, see "Troubleshooting" on page 40 for recommended actions.

---

## Adjusting the Span Setting

1. If you want to continue with adjusting the span setting, press and release the UP/YES button. **APPLY** will alternate with **SPAN Gas** on the top display line and the current gas reading will be on the bottom display line.

If you want to skip adjusting the span reading, press and release the DOWN/NO button. The display will indicate **Leaving Cal Mode** and the M2 will return to normal operation.

2. Screw the calibration gas cylinder into (onto for an H<sub>2</sub>S cylinder) the fixed flow regulator.
3. Turn the regulator knob counterclockwise to open the regulator.
4. Allow calibration gas to flow for two minutes. The gas reading should be stable after two minutes.
5. Turn the regulator knob clockwise to close it.

6. Unscrew the calibration gas cylinder from the fixed flow regulator and unscrew the calibration cup from the detector. For an ESM-01 detector, pull the calibration cup off of the ESM-01 sensor and screw the splashguard back onto the detector housing cap. The M2 will continue to display the maximum gas response on the display and retain the response level in its memory.
7. Adjust the gas reading up or down to match the calibration gas cylinder concentration by using the UP/YES and DOWN/NO buttons, then press and release the ENTER button.
8. The M2 will perform a span operation. The display will indicate **SPAN Gas PASS** for a few seconds, then indicate **SPAN Gas SAVED** before indicating **Leaving CAL Mode** for a few seconds.

---

**NOTE:** If the span adjustment fails, see “Troubleshooting” on page 40 for recommended actions.

---

9. The display will now alternate between the normal operation screen and the message **REMOVE CAL GAS** for 1 minute. If the calibration gas has not been removed from the detector, remove it now to avoid unwanted alarms.  
  
During this 1 minute period, the signal output will remain fixed at 3.5 mA and the relays will remain in their non-alarm state to avoid unwanted alarms while the calibration gas clears from the detector. At the end of the 1 minute period, the **REMOVE CAL GAS** message will stop appearing and the M2 will return to normal operation.
10. Store the components of the calibration kit in a safe place.

---

## Calibration, Oxygen Version

This section describes how to calibrate the oxygen version of the M2. It includes procedures to prepare for calibration, enter Calibration Mode, set the fresh air (span) reading, set the zero reading, and return to normal operation.

---

**WARNING:** *The M2 is not an active gas monitoring device during the calibration procedure. The 4-20 mA output signal will “freeze” at 17.4 mA and all relays will remain in their non-alarm state while the M2 in Calibration Mode. The output signal will not indicate current readings and the relays will not resume operating normally until the M2 is in normal operation again.*

---

### Preparing for Calibration

---

**NOTE:** The following procedure assumes the use of a calibration kit which includes a zero air (20.9% oxygen) calibration cylinder to set the fresh air reading, a 100% nitrogen (0% oxygen) calibration gas cylinder to set the zero reading, a fixed flow regulator with an on/off knob, a calibration cup, and a short piece of sample tubing to connect the regulator to the calibration cup. A cylinder with up to an 18% oxygen concentration may be used instead of a 100% nitrogen cylinder to set the zero reading.

---

---

**NOTE:** While in calibration mode, if there is no switch activity for the calibration time-out period the unit will return to normal operation. See “Viewing & Changing M2 Parameters” on page 32 for instructions to set the calibration time-out.

---

---

**NOTE:** The following procedure assumes that the oxygen concentration in the calibration area is not normal, 20.9%, but is oxygen deficient. If a fresh air environment can be verified, applying zero air to the detector is not necessary when adjusting the fresh air (span) setting.

---

1. Connect the calibration kit sample tubing to the calibration cup hose barb.
2. Screw the calibration cup onto the detector.
3. Connect the fixed flow regulator to the calibration cup using the sample tubing.

### Non-Intrusive Calibration

If the M2 is installed in a classified area and non-intrusive calibration is required, follow the instructions below, but do not remove the junction box cover. Use the magnetic wand accessory to actuate the magnetic switches instead of pushing the control switch buttons. To actuate a magnetic switch and perform the same operation as pressing a control switch button, touch the magnet in the end of the magnetic wand to the M2's glass cover directly above the magnetic switch you wish to actuate. Touching the glass and removing the wand is the same as pressing and releasing a button. Touching the glass and keeping the wand in place is the same as pressing and holding a button.

## Calibration Gas Response Memory Feature

The M2 has the capability to “remember” the detector’s response to the calibration gas after the gas is removed from the detector during the fresh air or zero adjustment procedure. This feature enables one person to perform calibration if the detector is mounted remotely from the M2. When zero air is applied to the M2 during a fresh air adjustment, the M2 will freeze the display reading at the highest response and the M2 will continue to display this reading and retain it in its memory until the fresh air adjustment procedure is completed. When calibration gas is applied to the M2 during a zero adjustment, the M2 will freeze the display reading at the lowest response to the calibration gas. The calibration gas can then be removed and the M2 will continue to display this reading and retain it in its memory until the zero adjustment procedure is completed.

### Adjusting the Fresh Air Setting

1. While in normal operation, press and hold the UP/YES button for 5 seconds to enter Calibration Mode. Release the button when the following screen appears.

Calib? YES/NO
------------------

2. If you want to continue with calibration, press and release the UP/YES button to continue. The display will indicate **OXYGEN CAL Mode** for a few seconds before showing **FreshAir Adjust?**.  
If you want to exit Calibration Mode, press and release the DOWN/NO button. The M2 will indicate **Leaving CAL Mode** and the M2 return to normal operation.
3. To continue with adjusting the fresh air (span) reading, press and release the UP/YES button. **ENTER** will alternate with **FreshAir** on the top display line and the current oxygen reading will be on the bottom display line.  
To skip adjusting the fresh air reading, press and release the DOWN/NO button. The display will indicate **ZERO w/Cal Gas?**. Skip to the next section, “Adjusting the Zero Setting”.
4. Screw the zero air cylinder into the fixed flow regulator.
5. Turn the regulator knob counterclockwise to open the regulator.
6. Allow zero air to flow for 2 minutes. If the oxygen concentration in the area is less than 20.9, the reading should stabilize after 2 minutes.
7. Turn the regulator knob clockwise to close the regulator.
8. Unscrew the zero air cylinder from the fixed flow regulator leaving the calibration cup on the detector. The M2 will continue to display the maximum gas response on the display and retain the response level in its memory.
9. Press and release the ENTER button. The M2 will perform a fresh air adjustment and the display will indicate **ZERO w/Cal Gas?**.

---

**NOTE:** If the fresh air adjustment fails, see “Troubleshooting” on page 40 for recommended actions.

---

## Adjusting the Zero Setting

1. If you want to continue with adjusting the zero setting, press and release the UP/YES button. **APPLY** will alternate with **ZERO Gas** on the top display line and the current oxygen reading will be on the bottom display line.

If you want to skip adjusting the zero reading, press and release the DOWN/NO button. The display will indicate **Leaving Cal Mode** and the M2 will return to normal operation.

2. Screw the 100% nitrogen gas cylinder into the fixed flow regulator.
3. Turn the regulator knob counterclockwise to open the regulator.
4. Allow gas to flow for 2 minutes. The gas reading should be stable after 2 minutes.
5. Turn the regulator knob clockwise to close the regulator.
6. Unscrew the nitrogen cylinder from the fixed flow regulator and unscrew the calibration cup from the detector. The M2 will continue to display the minimum gas response on the display and retain the response level in its memory.
7. Adjust the oxygen reading up or down to match the 100% nitrogen cylinder oxygen concentration of 0 by using the UP/YES and DOWN/NO buttons.

---

**NOTE:** If a cylinder other than a 100% nitrogen (0% oxygen) cylinder is used to set the zero reading, such as a cylinder with 12% oxygen, set the zero reading to match the cylinder's oxygen concentration.

---

8. Press and release the ENTER button. The M2 will perform a zero operation. The display will indicate **ZERO Gas PASS** for a few seconds, then indicate **ZERO Gas SAVED** before indicating **Leaving CAL Mode** for a few seconds.

---

**NOTE:** If the zero adjustment fails, see "Troubleshooting" on page 40 for recommended actions.

---

9. The display will now alternate between the normal operation screen and the message **REMOVE CAL GAS** for 1 minute. If the calibration gas has not been removed from the detector remove it now to avoid unwanted alarms.

During this 1 minute period, the signal output will remain fixed at 17.4 mA and the relays will remain in their non-alarm state to avoid unwanted alarms while the calibration gas clears from the detector. At the end of the 1 minute period, the **REMOVE CAL GAS** message will stop appearing and the M2 will return to normal operation.

10. Store the components of the calibration kit in a safe place.

---

## Replacing Components of the M2

### Replacing the Gas Detector

---

**NOTE:** For M2 versions that do not have a replaceable plug-in sensor, or if you determine that it is necessary to replace the entire detector, use the procedure in this section to change the entire detector. For M2 versions that include a replaceable plug-in sensor, see the appropriate instructions in the sections that follow this one to replace the plug-in sensor.

---

1. Turn off or disconnect power to the M2.
2. Remove the junction box cover.
3. Grasp the control PCB by its edges.
4. Gently pull until the control PCB is pulled away from the banana jacks. Take care not to pull too hard and damage the cable which connects the control and terminal PCB's.
5. Let the control PCB hang by the cable. The terminal strips are now visible on the terminal PCB. The control PCB may be left hanging while wiring is done. If desired, the control PCB may be disconnected from the cable and set aside while wiring.
6. Remove the detector terminal strip from its socket.
7. Disconnect the detector leads from the detector terminal strip. Note the position of the color-coded leads as you remove them.
8. Unscrew the detector from the junction box.
9. Guide the replacement detector leads through the bottom conduit hub of the junction box, then screw the mounting threads of the detector into the conduit hub.
10. Connect the detector leads to the detector terminal strip as follows:
  - Catalytic Combustible Gas Detector, IR Combustible Gas Detector, and IR CO<sub>2</sub> Detector  
Red wire to terminal labelled LEL RED, white to terminal labelled LEL WHT, green wire to terminal labelled LEL GRN, black wire to terminal labelled LEL BLK.
  - CO or H<sub>2</sub>S gas detector.  
Red wire to terminal labeled TOXIC +, black wire to terminal labelled TOXIC -.
  - ESM-01 Gas Detector  
Color coded wire to terminal labeled TOXIC +, black wire to terminal labelled TOXIC -. See Figure 20, "ESM-01 Toxic Detector Wiring" on page 22 for the wire color coding.
  - Oxygen gas detector.  
Green wire to terminal labelled OXY +, white wire to terminal labelled OXY -.
11. Re-install the detector terminal strip into its socket.
12. Re-install the control PCB (and ribbon cable if necessary). Be sure the ribbon cable is routed down below the control PCB so it will not be damaged by the cover when it is screwed back on.
13. Secure the junction box cover to the junction box.

14. Turn on or reconnect power to the M2.

---

**NOTE:** Allow the replacement detector to warm up for 15 minutes before you continue with the next step.

---

15. Calibrate the replacement detector as described in “Calibration, Combustible Gas, CO<sub>2</sub>, and Toxic Versions” on page 42 or “Calibration, Oxygen Version” on page 46.

### Replacing the CO or H<sub>2</sub>S Plug-in Sensor

1. Turn off or disconnect power to the M2.
2. Unscrew the detector cap from the housing body. Make sure not to lose the cap gasket. See Figure 3 or Figure 4 for an illustration of the CO or H<sub>2</sub>S detectors.
3. Unplug and remove the sensor.

---

**NOTE:** The CO sensor has a charcoal disk filter held onto it by a rubber retaining boot. When replacing a CO sensor, remove this filter and boot from the old sensor. RKI instruments recommends replacing the charcoal disk filter whenever a CO sensor is replaced. Re-install the charcoal disk filter and retaining boot before continuing.

---

4. Carefully match the replacement sensor’s male pins with the 4-socket pattern in the top section and plug it in.
5. Make sure the cap gasket is in place and screw the detector cap back onto the housing body.
6. Turn on or reconnect power to the M2.

---

**CAUTION:** Allow the replacement sensor to warm up for 15 minutes before you continue with the next step.

---

7. Calibrate the detector as described in “Calibration, Combustible Gas, CO<sub>2</sub>, and Toxic Versions” on page 42.

### Replacing the CO Sensor Charcoal Filter

The charcoal filter is used to scrub out interfering gasses from the environment being monitored, such as H<sub>2</sub>S and certain hydrocarbons. If you are experiencing unexplained upscale readings on a CO M2, the charcoal filter may be saturated and no longer scrubbing out interfering gases and it may be necessary to change the charcoal filter.

1. Turn off or disconnect power to the M2.
2. Unscrew the detector housing cap from the housing body. Make sure not to lose the cap gasket. See Figure 3 for an illustration of the CO detector.
3. Remove the rubber retaining boot with the charcoal filter disk from the sensor.
4. Replace the charcoal filter disk in the rubber retaining boot and install the boot onto the sensor.
5. Make sure that the cap gasket is in place and screw the detector cap back onto the housing body.
6. Turn on or reconnect power to the M2.

## Replacing a CSA Type Oxygen Plug-in Sensor

1. Turn off or disconnect power to the M2.
2. Unscrew the detector cap from the top section. Take care not to lose the cap gasket. See Figure 2 for an illustration of the oxygen detector.
3. Unplug and remove the sensor.
4. Carefully match the replacement sensor's male pins with the 2-socket pattern in the top section and plug it in.
5. Make sure the cap gasket is in place and screw the detector cap back on to the detector housing.
6. Turn on or reconnect power to the M2.

---

**NOTE:** Allow the replacement sensor to warm up for 15 minutes before you continue with the next step.

---

Calibrate the detector as described in "Calibration, Combustible Gas, CO<sub>2</sub>, and Toxic Versions" on page 42

## Replacing an ESM-01 Plug-in Sensor

1. Turn off or disconnect power to the M2.
2. Unscrew the detector cap from the detector housing body. Take care not to lose the cap gasket. If the splashguard begins to unscrew from the detector cap, make sure to remove the detector cap also. See Figure 2 for an illustration of the ESM-01 detector.
3. Unplug and remove the sensor.
4. Carefully match the replacement sensor's plug with the socket in the housing body and plug it in.

---

**WARNING:** *The ESM-01 detectors cannot be changed from one type to another. Replace the plug-in sensor only with the same type of ESM-01 sensor.*

---

5. Make sure the cap gasket is in place and screw the detector cap back onto the housing body. If the splash guard was unscrewed from the detector cap, screw it back onto the detector cap.
6. Turn on or reconnect power to the M2.

---

**NOTE:** Allow the replacement sensor to warm up for 15 minutes before you continue with the next step.

---

Calibrate the detector as described in "Calibration, Combustible Gas, CO<sub>2</sub>, and Toxic Versions" on page 42

# Chapter 8: RS-485 Modbus Output

---

## Overview

This chapter describes the M2's RS-485 Modbus output and how to configure the M2 to make use of it. It also discusses how to wire the M2 into a Modbus system.

The M2 provides an RS-485 serial communications interface. It is a Modbus Slave Device, supporting 2-wire RS-485 Modbus RTU serial communications.

---

## Wiring the M2 in a Modbus System

The M2 is a 2-wire Modbus RTU device. When wiring the M2 into a Modbus system, adhere to standard Modbus wiring practices per the Modbus Over Serial Line Specification and Implementation Guide V1.0 or later. This document can be found online at [www.modbus.org/specs.php](http://www.modbus.org/specs.php).

The Modbus protocol supports a maximum of 247 unique slave addresses (1-247). The M2's line driver provides for up to 32 M2s to be connected together without the need for a repeater. Figure 24 & Figure 25 below illustrate typical M2 wiring configurations. If more than 32 M2s need to be connected together, RS-485 repeater(s) should be used such that no more than 32 M2s reside on any given network segment.

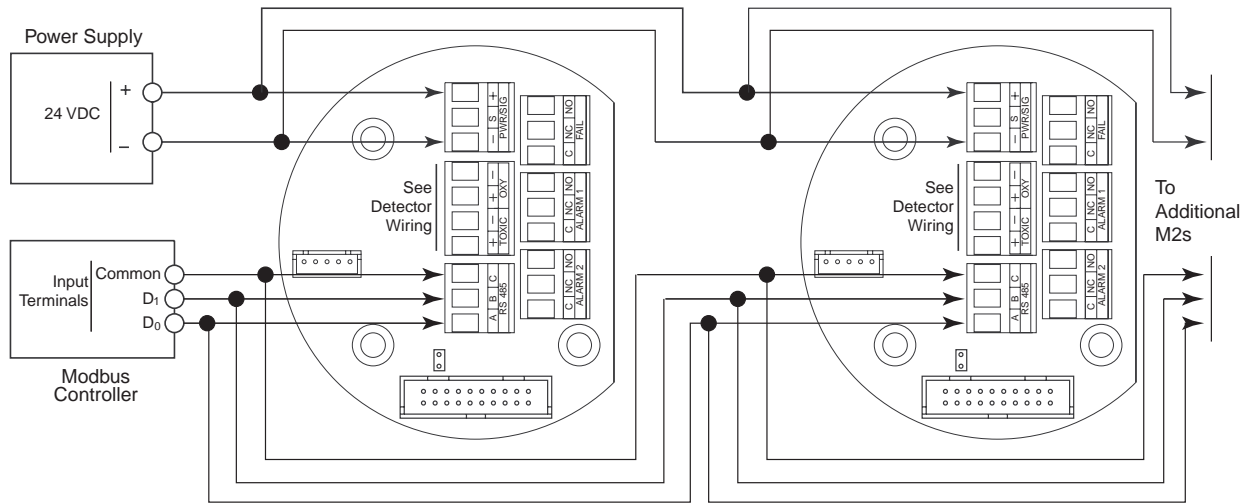
The MODBUS terminal strip is located on the terminal PCB (See Figure 6). The following signals are available at the Modbus terminal strip:

**Table 10: Modbus Terminal Strip Signals**

<b>Modbus Terminal Label (RS-485 Name)</b>	<b>Modbus Signal Name</b>
A	D0
B	D1
C	Common

### Recommended Modbus Wiring

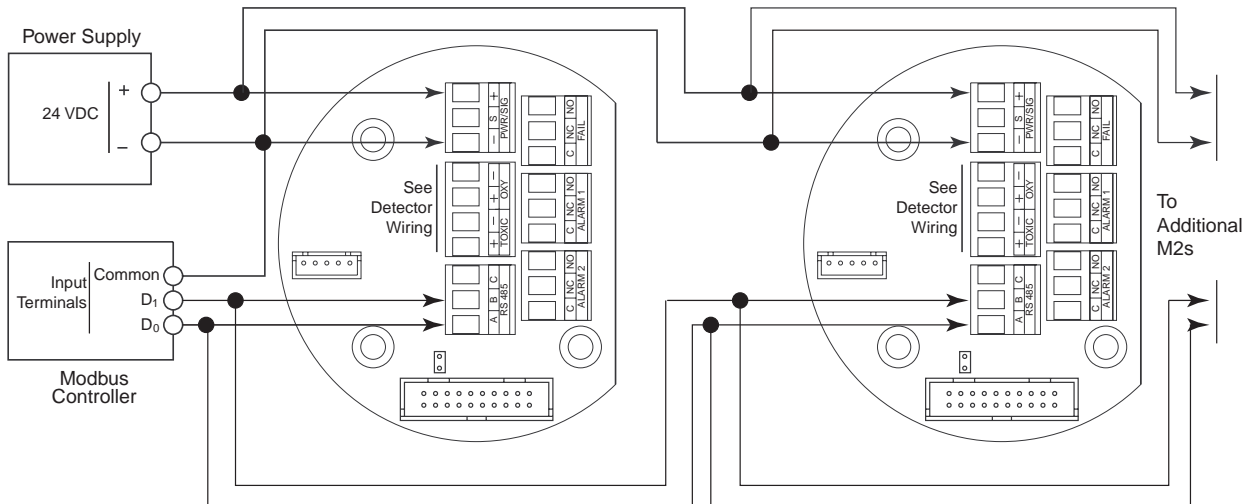
The recommended Modbus wiring for the M2 is illustrated in Figure 22 below. In this configuration, 5 wires are used for the wiring with the M2. Figure 22 also illustrates typical alarm device wiring.



**Figure 22: Recommended Modbus Wiring**

### Alternate Modbus Wiring For Existing Installations

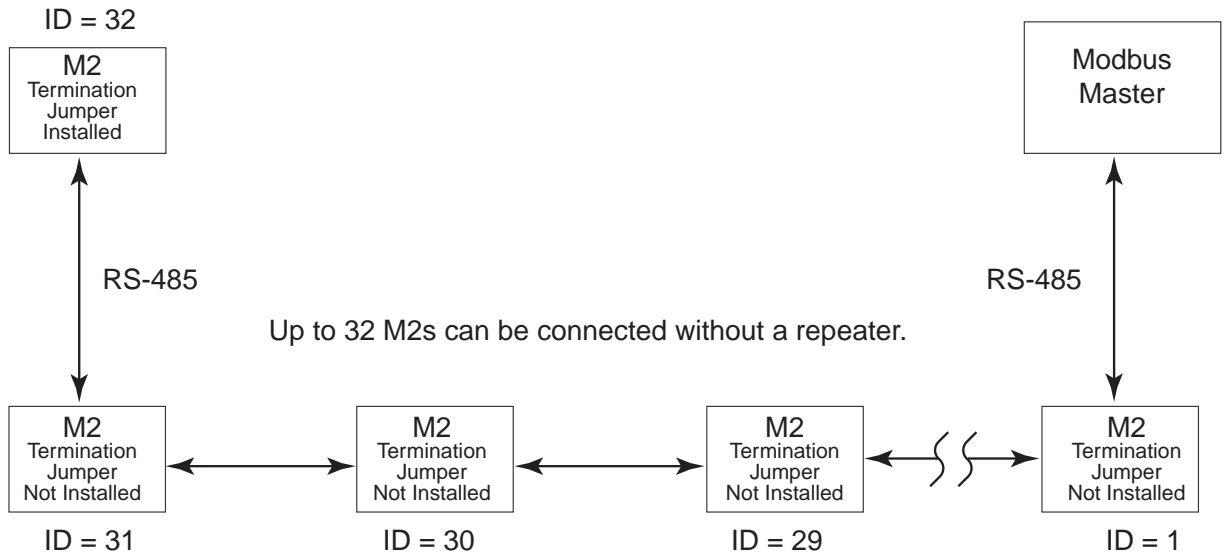
Although the wiring shown in Figure 22 is recommended, it is possible to wire the M2 into a Modbus system with only 4 wires in situations where a pre-existing system is being replaced and wiring is already in place. This should only be done if wiring for a system that is being replaced is already installed and it is not practical to run another wire. See Figure 23 below for this wiring configuration. In this configuration, the wire between the “C” terminal on the M2 and the Common terminal on the Modbus controller is omitted. Instead, the Common terminal on the Modbus controller is connected to the “-” of the 24 VDC power supply.



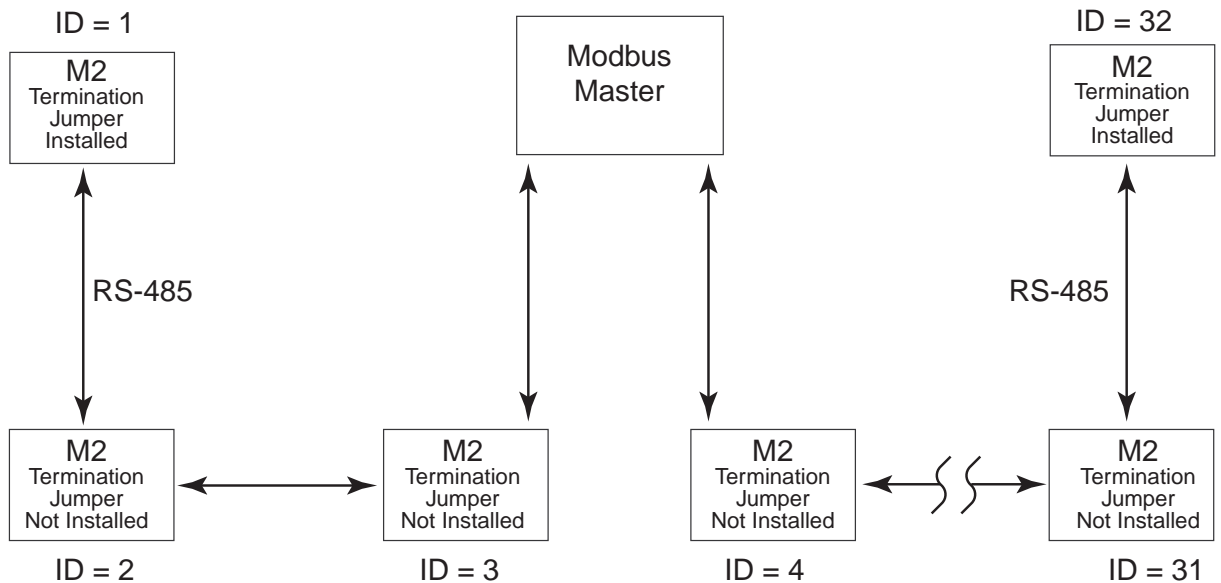
**Figure 23: Alternate Modbus Wiring**

## Termination Jumper

The M2 includes a 2-pin termination header (see Figure 6) that is used when the M2 is used in a Modbus system. Every M2 is supplied with a termination jumper (a jumper block) installed onto this header. If the M2 is not used in a Modbus system, this jumper has no function. When the M2 is installed in a Modbus system, this jumper must be installed in an M2 that is at the end of a Modbus line. Any M2 in a Modbus system that is not at the end of a line must have the termination jumper removed (see Figure 24 & Figure 25 below).



**Figure 24: Multiple M2s in a Daisy Chain Configuration**



Up to 32 M2s can be connected without a repeater.

**Figure 25: Multiple M2s in a Two Branch Configuration**

---

## Using the M2 in a 4-wire Modbus System

Although the M2 is a 2-wire Modbus RTU device, it can be used with a 4-wire Modbus controller if the system wiring is modified as follows:

- Connect the controller's TxD0 and RxD0 wires together and use this connection as the 2-wire Modbus D0 signal.
- Connect the controller's TxD1 and RxD1 wires together and use this connection as the 2-wire Modbus D1 signal.
- Connect these D0 and D1 signals and the common wire from the controller to the 2-wire Modbus Network of M2s.

---

## Modbus Mode

Modbus Mode allows you to configure various parameters relating to the Modbus setup of the M2. Modbus Mode includes a 5-minute time-out feature. If you do not press a control button for 5 minutes, the M2 automatically returns to normal operation.

---

**NOTE:** If the M2 returns to normal operation because of a time-out, it enters a warm-up period just as it does when it is first turned on.

---

1. While in normal operation, simultaneously press and hold the DOWN/NO and ENTER buttons for 5 seconds to enter Modbus Mode. Release the buttons when the following screen appears.

Set Up  
Modbus?

2. To exit Modbus Mode, press and release the DOWN/NO button. The M2 will return to normal operation.  
  
To continue in Modbus Mode, press and release the UP/YES button. The current ENABLED/DISABLED setting will appear.
3. If you want to change the currently displayed parameter, use the UP/YES and DOWN/NO buttons to adjust it to the desired setting, then press ENTER to continue to the next parameter.

If the currently displayed parameter setting is OK, press the ENTER button to proceed to the next parameter.

Table 11 lists the M2 Modbus Mode parameters you can set. Table 11 also lists the factory set value for each parameter.

**Table 11: Configuration Parameters**

Modbus Mode Parameter	Available Settings & Description
Enabled/Disabled	Can be set to ENABLED or DISABLED (factory setting). Enables or disables the Modbus output.
Slave ID	The Slave ID can be set to values from 1 (factory setting) to 247.  The M2 will only receive messages from the Master which are addressed to this Slave ID (except for broadcast messages which are received by all slaves)
Baud Rate	Can be set to 1200, 2400, 4800, 9600 (factory setting), 14440, & 19200
Parity	EVEN (factory setting), ODD, NONE
Response Delay	The response delay can be set from 0 (factory setting) to 20 mS.  This is an optional additional delay inserted by the M2 prior to returning a response message to the Master. It may be helpful in some installations where the Master's preparedness to receive responses might be delayed.

4. When you have scrolled through all the adjustable parameters, **SAVE IT? YES/NO** appears on the display.
5. If you do not wish to save the adjustments, press and release the **DOWN/NO** button. The **DO OVER? YES/NO** message will display. Press and release the **DOWN/NO** button. The **ABORT? YES/NO** message will display. Press the **UP/YES** button to return to normal operation.

If you wish to change some of the adjustments made, press and release the **DOWN/NO** button. The **DO OVER? YES/NO** message will display. Press and release the **UP/YES** button. The **Re-do MB Setup** message will display and the M2 will return to the first adjustable parameter. Go back to step 3 and continue.

If you want to save the adjustments made, press and release the **UP/YES** button. **Modbus Saved** is indicated on the display for a few seconds and the M2 returns to normal operation.

---

**NOTE:** All M2s on a Modbus network must be configured with the same baud rate and parity, and each M2 must have a unique slave ID. For an M2 to participate on a network, the **ENABLED/DISABLED** setting must be set to **ENABLE**.

---

## Supported Modbus Functions

The M2 supports Function Code 03, Read Holding Registers. There are a total of 22 registers available to be read via this Function Code. The register assignments detailed below were implemented in M2 firmware version 4.1. Please see revision A of the M2 manual if you have an M2 with a firmware version previous to 4.1.

### Registers 1 - 3

The format (bit & field assignments) for registers 1 - 3 is shown below in Table 12 - Table 14.

**Table 12: Register 1, Numerical Reading with Sign & Decimal Point Bit & Field Assignments**

Bit(s)	Value & Field
[15]	<u>Sign of Reading</u> 0 = Positive 1 = Negative
[14:13]	<u>Format of Reading</u> 0 = XXX (no decimal point) 1 = XX.X 2 = X.XX 3 = .XXX
[12:0]	Numerical value of display reading (8000 max)

**Table 13: Register 2, Operating State, Alarms & Relays Bit & Field Assignments**

Bit(s)	Value
[15:12]	<u>Operating State</u> 0 = Undefined 1 = Initialization 2 = Normal 3 = Warm-up 4 = Fail 5 = Calibration 6 = Post-Calibration 7 = Low Power 8 = Setup
[11:9]	Unused spare bits always read as 0's
[8]	<u>Fail Status</u> 0 = Fail Not Asserted 1 = Fail Asserted

**Table 13: Register 2, Operating State, Alarms & Relays Bit & Field Assignments (Continued)**

Bit(s)	Value
[7:6]	<u>Alarm 2 Status</u> 0 = No Alarm 1 = Unacknowledged Alarm 2 = Acknowledged Alarm 3 = Unused Code
[5:4]	<u>Alarm 1 Status</u> 0 = No Alarm 1 = Unacknowledged Alarm 2 = Acknowledged Alarm 3 = Unused Code
[3]	<u>Overscale Status</u> 0 = Not Overscale 1 = Overscale
[2]	<u>Fail Relay Status</u> 0 = Not Energized 1 = Energized
[1]	<u>Alarm 2 Relay Status</u> 0 = Not Energized 1 = Energized
[0]	<u>Alarm 1 Relay Status</u> 0 = Not Energized 1 = Energized

**Table 14: Register 3, Supply Voltage Bit & Field Assignments**

Bit(s)	Value & Field
[15:9]	Unused, always read as 0
[8:0]	Supply Voltage Reading, 0.1 volt per count

### Registers 4 - 11

The 16 bytes in these registers contain the same ASCII text information that is displayed on the M2's LCD (NULL Terminated).

### Register 12

Register 12 is the range (full scale readout).

### Register 13

Register 13 is the alarm 1 setpoint.

The decimal point location is the same as specified in Register 1.

## **Register 14**

Register 14 is the alarm 2 setpoint.

The decimal point location is the same as specified in Register 1.

## **Registers 15 - 19**

Registers 15 - 19 are the Gas Name ASCII String (NULL Terminated).

## **Registers 20 - 22**

Registers 20 - 22 are the Gas Units String (NULL Terminated).

## Parts List

Table 15 lists replacement parts and accessories for the M2 Transmitter.

**Table 15: Parts List**

Part Number	Description
06-1248RK	Calibration kit sample tubing (3/16 in. x 5/16 in.; specify length when ordering)
07-0033RK	Cap gasket, for CSA type CO and H <sub>2</sub> S detector
07-0125RK	Cap gasket, for ESM-01 detector
07-0203RK	Rubber retaining boot for charcoal filter
18-0405RK-01	Junction box w/o cover
18-0404RK	Junction box cover, with lens
33-7101RK	Charcoal filter disk
45-6132RK	Termination jumper
61-0140RK	LEL detector, catalytic type, UL version
61-0140RK-05	LEL detector, catalytic type, CSA version
61-0190RK-CH4	CH <sub>4</sub> LEL detector, IR type
61-0190RK-HC	HC LEL detector, IR type, propane calibration
61-0191RK-02	CO <sub>2</sub> detector, IR type, 0 - 5,000 ppm
61-0191RK-03	CO <sub>2</sub> detector, IR type, 0 - 5% volume
61-0192RK-CH4	CH <sub>4</sub> detector, IR type, 0 - 100% volume
65-1025RK	Plug-in oxygen sensor, for 65-2514RK
65-2300RK-ASH3	ESM-01 detector, 0 - 1.50 ppm arsine
65-2300RK-CL2	ESM-01 detector, 0 - 3.00 ppm chlorine
65-2300RK-NH3	ESM-01 detector, 0 - 75.0 ppm ammonia
65-2300RK-NO	ESM-01 detector, 0 - 100 ppm nitric oxide
65-2300RK-PH3	ESM-01 detector 0 - 1.00 ppm phosphine
65-2300RK-SO2	ESM-01 detector, 0 - 6.00 ppm sulphur dioxide
65-2423RK-05	H <sub>2</sub> S detector assembly, CSA version
65-2433RK-05	CO detector assembly, CSA version
65-2510RK	Oxygen detector, partial pressure type
65-2511RK	Oxygen detector, capillary type

**Table 15: Parts List**

<b>Part Number</b>	<b>Description</b>
65-2514RK	Oxygen detector, CSA version, capillary type
71-0107RK	<i>M2 Transmitter Operator's Manual (this document)</i>
81-0002RK-01	Calibration cylinder, 50% LEL hydrogen in air, 34 liter steel
81-0002RK-03	Calibration cylinder, 50% LEL hydrogen in air, 103 liter steel
81-0004RK-01	Calibration cylinder, 50% LEL propane in air, 34 liter steel
81-0004RK-03	Calibration cylinder, 50% LEL propane in air, 103 liter steel
81-0007RK-01	Calibration cylinder, 15% LEL hexane in air, 34 liter steel
81-0012RK-01	Calibration cylinder, 50% LEL methane in air, 34 liter steel
81-0012RK-03	Calibration cylinder, 50% LEL methane in air, 103 liter steel
81-0064RK-01	Calibration cylinder, CO, 50 ppm in air, 34 liter steel
81-0064RK-03	Calibration cylinder, CO, 50 ppm in air, 103 liter steel
81-0070RK-01	Calibration cylinder, CO <sub>2</sub> , 2,000 ppm in nitrogen, 34 liter steel
81-0070RK-03	Calibration cylinder, CO <sub>2</sub> , 2,000 ppm in nitrogen, 103 liter steel
81-0072RK-01	Calibration cylinder, CO <sub>2</sub> , 2.5% in nitrogen, 34 liter steel
81-0072RK-03	Calibration cylinder, CO <sub>2</sub> , 2.5% in nitrogen, 103 liter steel
81-0076RK-01	Zero air calibration cylinder, 34 liter steel
81-0076RK-03	Zero air calibration cylinder, 103 liter steel
81-0078RK-01	Calibration cylinder, 100% nitrogen, 34 liter steel (used for setting oxygen zero)
81-0078RK-03	Calibration cylinder, 100% nitrogen, 103 liter steel (used for setting oxygen zero)
81-0151RK-02	Calibration cylinder, H <sub>2</sub> S, 25 ppm in nitrogen, 58 liter aluminum
81-0151RK-04	Calibration cylinder, H <sub>2</sub> S, 25 ppm in nitrogen, 34 liter aluminum
81-0170RK-02	Calibration cylinder, 5 ppm SO <sub>2</sub> in nitrogen, 58 liter
81-0170RK-04	Calibration cylinder, 5 ppm SO <sub>2</sub> in nitrogen, 34 liter
81-0175RK-02	Calibration cylinder, 10 ppm NH <sub>3</sub> in nitrogen, 58 liter
81-0175RK-04	Calibration cylinder, 10 ppm NH <sub>3</sub> in nitrogen, 34 liter
81-0185RK-02	Calibration cylinder, 0.5 ppm PH <sub>3</sub> in nitrogen, 58 liter
81-0185RK-04	Calibration cylinder, 0.5 ppm PH <sub>3</sub> in nitrogen, 34 liter
81-0192RK-02	Calibration cylinder, 2 ppm Cl <sub>2</sub> in nitrogen, 58 liter

**Table 15: Parts List**

<b>Part Number</b>	<b>Description</b>
81-0192RK-04	Calibration cylinder, 2 ppm Cl <sub>2</sub> in nitrogen, 34 liter
81-1050RK	Regulator, with gauge and knob, 0.5 liter/minute continuous flow, for combustible gas, nitrogen, zero air, and CO cylinders.
81-1051RK	Regulator, with gauge and knob, 0.5 liter/minute continuous flow, for H <sub>2</sub> S cylinder
81-1051RK-25	Regulator, fixed flow, w/gauge & knob, 0.25 LPM, for 34 liter aluminum/58 liter/103 liter cylinder <b>(Used to calibrate NH<sub>3</sub> ESM-01 M2 only)</b>
81-1103RK	Calibration cup, for 3/4" NPT IR detectors, combustible gas and CO <sub>2</sub>
81-1117RK	Calibration cup, for catalytic LEL, CO, H <sub>2</sub> S, and oxygen detectors
81-1138RK	Calibration cup, general (SO <sub>2</sub> ), for ESM-01, use 0.5 LPM flow
81-1138RK-CL2	Calibration cup, for ESM-01 Cl <sub>2</sub> , use 0.5 LPM flow
81-1138RK-NH3	Calibration cup, for ESM-01 NH <sub>3</sub> , use 0.25 LPM flow
81-1190RK	Splashguard, for ESM-01 detector cap
ES-1531-CO	CO sensor, plug-in
ES-1537-H2S	H <sub>2</sub> S sensor, plug-in
ESM-015-NO	ESM-01 plug-in sensor, 0 - 100 ppm nitric oxide
ESM-01DH-ASH3	ESM-01 plug-in sensor, 0 - 1.50 ppm arsine
ESM-01DH-D-SO2	ESM-01 plug-in sensor, 0 - 6.00 ppm sulphur dioxide, diffusion type only
ESM-0DH-PH3	ESM-01 plug-in sensor, 0 - 1.00 ppm phosphine
ESM-01R-D-NH3	ESM-01 plug-in sensor, 0 - 75.0 ppm ammonia, diffusion type only
ESM-K01-D-CL2	ESM-01 plug-in sensor, 0 - 3.00 ppm chlorine, diffusion type only
NC-6234-01	Hydrogen specific LEL detector, catalytic type, UL version
NC-6234-05	Hydrogen specific LEL detector, catalytic type, CSA version

## Appendix A: Control Button Quick Reference Guide

The M2's control buttons allow access to operational modes, resetting of alarms, and display of the Information Screen. Table 16 shows which button combinations perform these functions and which parameters are available for adjustment while in the operational modes. While in these modes, display prompts showing a "?" require you to respond by pressing either the UP/YES (for yes) or DOWN/NO (for no) button. To change parameter settings, use the UP/YES and DOWN/NO buttons to get the desired setting, then press and release the ENTER button to accept the setting.

**Table 16: Control Button Quick Reference Chart**

<b>Mode Entered or Function Performed</b>	<b>Button Combination</b>	<b>Adjustable or Viewable Parameters</b>
Alarm Reset	Press and Release ENTER	n/a
Show Information Screen	Press and Hold DOWN/NO	<ul style="list-style-type: none"> <li>• Input Voltage</li> <li>• M2 Version/Revision Information</li> </ul>
Calibration Mode	Press and Hold UP/YES for 5 seconds	<ul style="list-style-type: none"> <li>• Fresh Air Adjust</li> <li>• Span (or Zero for Oxygen) Adjust with Calibration Gas</li> </ul>
Configuration Mode	Press and Hold UP/YES & ENTER for 5 seconds	<ul style="list-style-type: none"> <li>• Alarm Levels</li> <li>• Increasing or Decreasing Alarms</li> <li>• Normally Energized or Normally De-energized Relays</li> <li>• Latching or Self-resetting Alarms</li> <li>• Alarm On Delay</li> <li>• Alarm Off Delay (if self-resetting)</li> <li>• Zero Suppression</li> <li>• Noise Filter</li> <li>• Calibration Time-out Period</li> </ul>
Gas Type Mode	Press and Hold UP/YES and DOWN/NO for 5 seconds	Gas Type
Modbus Mode	Press and Hold DOWN/NO and ENTER for 5 seconds	<ul style="list-style-type: none"> <li>• Enable or Disable Modbus</li> <li>• Slave ID</li> <li>• Baud Rate</li> <li>• Parity</li> <li>• Response Delay</li> </ul>