



## Passport<sup>®</sup> PID II Organic Vapor Monitor

### User's Manual

#### **WARNING**

THIS MANUAL MUST BE CAREFULLY READ AND FOLLOWED BY ALL PERSONS WHO HAVE OR WILL HAVE THE RESPONSIBILITY FOR USING OR SERVICING THE PRODUCT. Like any piece of complex equipment, the product will perform as designed only if it is used and serviced in accordance with the manufacturer's instructions. OTHERWISE IT COULD FAIL TO PERFORM AS DESIGNED AND PERSONS WHO RELY ON THIS PRODUCT FOR THEIR SAFETY COULD SUSTAIN SEVERE PERSONAL INJURY OR DEATH.

The warranties made by Mine Safety Appliances Company with respect to the product are voided if the product is not used and serviced in accordance with the instructions in this manual. Please protect yourself and others by following them. We encourage our customers to write or call regarding this equipment prior to use, or for any additional information relative to use or repairs.

#### **CAUTION**

For safety reasons this equipment must be operated by qualified personnel only.

In the US, contact your nearest stocking location by dialing toll-free, 1-800-MSA-2222.

To contact MSA International, dial 1-412-967-3000 or 1-800-MSA-7777.

© MINE SAFETY APPLIANCES COMPANY 2000

Manufactured by  
MSA INSTRUMENT DIVISION  
P.O. Box 427, Pittsburgh, Pennsylvania 15230  
(L) Rev. 6

815253

---

# Contents

<b>Section 1. General Information .....</b>	<b>1-1</b>
1.1. Certifications .....	1-1
Intrinsic Safety .....	1-1
1.2. Theory and Definitions .....	1-1
PID Theory .....	1-1
Calculating Concentration.....	1-1
<i>Zero gas</i> .....	1-2
<i>Span gas</i> .....	1-2
Response Factors.....	1-3
Calculating a Response Factor.....	1-3
Calculating Exposures.....	1-4
Threshold Limit Values (TLV).....	1-4
<i>TLV-Time Weighted Average (TWA)</i> .....	1-5
<i>TLV-Short Term Exposure Limit (STEL)</i> .....	1-5
<i>TLV-Ceiling (TLV-C)</i> .....	1-6
<b>Section 2. Safety Information.....</b>	<b>2-1</b>
2.1. Warnings.....	2-1
2.2. Cautions .....	2-3
<b>Section 3. Using Your Monitor .....</b>	<b>3-1</b>
3.1. Physical Description .....	3-1
PID Lamp, Inlet & Outlet Ports .....	3-2
3.2. Instrument Manual .....	3-3
International Icons .....	3-3

3.3.	Instrument Software .....	3-4
	Display Page .....	3-4
	Instrument Configuration .....	3-5
	Power Saving Mode .....	3-5
3.4.	Preparing for Startup .....	3-6
	Probe Assembly.....	3-6
	Connecting the Probe .....	3-6
	Installing the Battery Pack .....	3-7
	Self-Test Messages.....	3-8
	Set Date and Time.....	3-9
	Changing the Date and Time.....	3-9
3.5.	Instrument Startup.....	3-11
	Fresh Air Setup .....	3-13
	Perform a Fresh Air Setup.....	3-13
	Bypass Fresh Air Setup .....	3-13
3.6.	Checking the Pump Module.....	3-14
3.7.	Calibration Check.....	3-14
3.8.	Exposure Page .....	3-15
	<i>Time-out Feature</i> .....	3-15
	Normal Exposure Page .....	3-15
	<i>Available Buttons</i> .....	3-15
	<i>Analog Bar Graph Display</i> .....	3-16
	Alarmed Exposure Page .....	3-16
3.9.	Concentration Alarms.....	3-17
	Resetting a Concentration Alarm.....	3-18
3.10.	System Alarms .....	3-18

---

BATT System Alarm.....	3-20
Resetting a BATT System Alarm .....	3-20
BATTERY SHUTDOWN System Alarm.....	3-20
LAMP System Alarm .....	3-21
Resetting a LAMP System Alarm.....	3-21
PUMP System Alarm .....	3-21
Resetting a PUMP System Alarm .....	3-21
3.11. Sample Gas Page .....	3-22
3.12. Battery Condition Page.....	3-23
Battery System Alarm .....	3-23
3.13. Date and Time Page .....	3-24
3.14. Peak Reading Page .....	3-24
Resetting the Peak Reading .....	3-25
3.15. Short Term Exposure Limit (STEL) Page .....	3-26
STEL Alarm .....	3-27
Acknowledging a STEL Alarm .....	3-27
Resetting a STEL Period .....	3-27
3.16. TWA Page.....	3-29
TWA Alarm.....	3-29
Acknowledging a TWA Alarm.....	3-30
Resetting a TWA Period.....	3-30
3.17. Open User Setup Page .....	3-31
Starting Setup Mode.....	3-31
3.18. Instrument Shut Down.....	3-32
Battery Pack Removal .....	3-33
3.19. Recharging Nickel-Cadmium (Ni-Cd) Battery Packs .....	3-33

<b>Section 4. Defining the Setup Parameters .....</b>	<b>4-1</b>
4.1. Setup Mode Display Pages.....	4-1
4.2. Select Sample Gas .....	4-1
Changing the Sample Gas .....	4-1
4.3. Select Label.....	4-2
Changing the Storage Label .....	4-3
4.4. Select Warning Level .....	4-4
Changing the Warning Level .....	4-4
4.5. Select Alarm Level .....	4-5
Changing the Alarm Level .....	4-5
4.6. Select STEL Level.....	4-6
Changing the STEL Level.....	4-6
4.7. Select TWA Level .....	4-7
Changing the TWA Level .....	4-8
<b>Section 5. Calibrating .....</b>	<b>5-1</b>
5.1. Calibration .....	5-1
Calibration Equipment .....	5-1
5.2. Calibration Check.....	5-2
5.3. Calibration Procedure.....	5-2
Initiate Calibration .....	5-2
Select the Calibration Gas .....	5-5
Applying Zero Gas .....	5-6
Applying the Span Gas.....	5-7
<b>Section 6. Cleaning &amp; Routine Care.....</b>	<b>6-1</b>
6.1. Storage .....	6-1
6.2. Shipping.....	6-1
6.3. Technical Support .....	6-2

6.4. Quick Tab Troubleshooting Guide .....	6-3
6.5. Maintenance & Technical Procedures .....	6-4
Removing and Cleaning the PID Lamp .....	6-4
Pump Module Replacement .....	6-6
Pump Board Replacement .....	6-7
Pump & Drive Replacement .....	6-7
Pump Motor Replacement .....	6-8
Rebuilding the Pump & Drive .....	6-8
Main Board Replacement .....	6-9
Display Module Replacement .....	6-11
<b>Section 7. Appendices.....</b>	<b>7-1</b>
Appendix A: Response Factor Table .....	7-1
Appendix B: Additional Response Factors .....	7-3
Appendix C: Specifications.....	7-5
Appendix D: Options and Accessories .....	7-6
Appendix E: Ionization Potentials.....	7-9

## List of Figures

Figure 1-1. Calibrated Response Curve .....	1-2
Figure 3-1. Passport PID II Organic Vapor Monitor.....	3-1
Figure 3-2. Sample Inlet and Data Port.....	3-2
Figure 3-3. Exposure Display Page .....	3-4
Figure 3-4. Sequence of Display Pages.....	3-5
Figure 3-5. Attaching the Sample Line .....	3-6
Figure 3-6. Installing a Water Trap Filter .....	3-7
Figure 3-7. Installing the Battery Pack.....	3-7
Figure 3-8. Operating System Software Version.....	3-8
Figure 3-9. Self-Test Display Page.....	3-8
Figure 3-10. Date and Time Display Page.....	3-9
Figure 3-11. Date and Time Selection Page .....	3-10
Figure 3-12. Startup Sequence .....	3-12
Figure 3-13. Exposure Page .....	3-16
Figure 3-14. Alarmed Exposure Display – Concentration Alarm.....	3-17
Figure 3-15. Alarmed Exposure Display-Lamp System Alarm .....	3-19
Figure 3-16. Sample Gas Page .....	3-23
Figure 3-17. Battery Voltage Page .....	3-23
Figure 3-18. Date and Time Page.....	3-24
Figure 3-19. Peak Reading Page .....	3-25
Figure 3-20. Resetting the Peak Reading.....	3-26
Figure 3-21. STEL Page .....	3-27
Figure 3-22. Resetting a STEL Alarm.....	3-28
Figure 3-23. TWA Page.....	3-29
Figure 3-24. Resetting a TWA Alarm .....	3-31

Figure 3-25. Open User Setup Page .....	3-32
Figure 3-26. Power Down Page.....	3-32
Figure 3-27. Battery Pack Removal.....	3-33
Figure 3-28. Single Unit MSA Omega Ni-Cd Charger Accessory .....	3-34
Figure 4-1. Selecting the Sample Gas .....	4-2
Figure 4-2. Selecting a Storage Label.....	4-3
Figure 4-3. Selecting the Warning Level.....	4-5
Figure 4-4. Selecting the Alarm Level .....	4-6
Figure 4-5. Selecting the STEL Level .....	4-7
Figure 4-6. Selecting the TWA Level.....	4-8
Figure 5-1. Calibration Equipment .....	5-1
Figure 5-2. Calibration Screen .....	5-3
Figure 5-3. Calibration Sequence.....	5-4
Figure 5-4. Calibration Gas Display Page .....	5-5
Figure 5-5. Apply Zero Gas Display Page .....	5-6
Figure 5-6. Apply Span Gas Display Page.....	5-7
Figure 5-7. Adjusting the Span Gas Concentration .....	5-8
Figure 6-1. Cleaning the PID Lamp .....	6-5
Figure 6-2. Removing Debris from the PID Lamp.....	6-5
Figure 6-3. Removing the Chassis.....	6-10
Figure 6-4. Location of Mounting Screws & Power Connector .....	6-10

## List of Tables

Table 3-1. International Icons .....	3-3
Table 3-2. Status Message & Concentration Alarm Indicated.....	3-18
Table 3-3. Status Message and System Alarm Indicated.....	3-19
Table 3-4. Status Messages and Battery Condition Indicated.....	3-24
Table 3-5. Status Messages and Peak Reading Condition Indicated....	3-25
Table 3-6. Status Messages and STEL Condition Indicated.....	3-27
Table 3-7. Status Messages and TWA Condition Indicated .....	3-29

## **Section 1. General Information**

### **1.1. Certifications**

#### *Intrinsic Safety*

The Passport PID II Organic Vapor Monitor is listed to the Underwriters Laboratories Standard for Safety UL 913, as an Intrinsically Safe Apparatus approved for use in Class I, Division I, Groups A, B, C, D; Class II Division I, Groups E, F, G and Class III, Hazardous Locations when used in accordance with the Passport PID II Instruction Manual. (Listing number: E112042.)

### **1.2. Theory and Definitions**

To support the safe and effective operation of the Passport PID II Organic Vapor Monitor, MSA believes operators should have a working knowledge of how the instrument functions, not just how to make it work. The information presented in this section supplements the hands-on operational instruction provided in the rest of the manual.

#### *PID Theory*

In a photoionization detector (PID), sample gas is pumped through a small chamber illuminated by an ultraviolet lamp. Substances in the sample gas with ionization potentials less than or equal to the energy of the ultraviolet light are ionized. An electric field set up within the chamber forces the freed electrons to a collector pin that directs the current to the instrument's amplifier. This current is called the detector response. The software interprets and reports the detector response as a concentration.

#### *Calculating Concentration*

There is a relationship between the detector current and concentration. This response can be expressed as a straight line on a graph, where only two points are necessary to define that line. These two points are defined by determining the detector response to reference gases of known concentration. The reference gases are called zero gas and span gas.

By plotting the detector response to reference gases of known concentration, the software generates a curve where the slope of that curve represents the calibrated response per unit concentration.

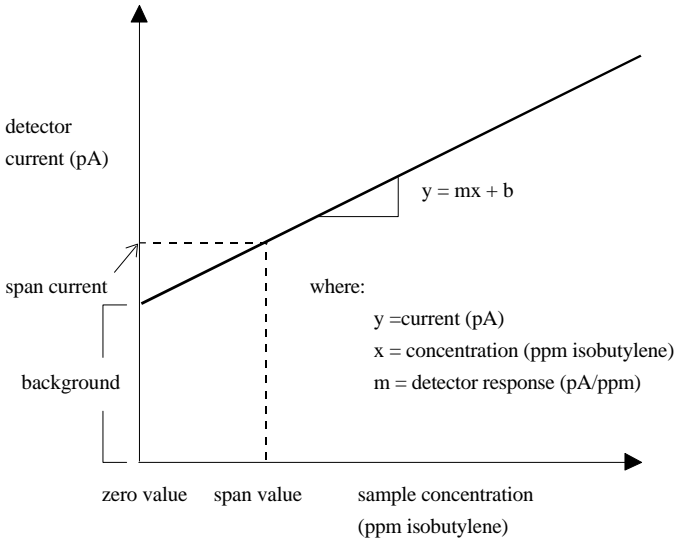

**Figure 1-1. Calibrated Response Curve**

### *Zero gas*

Zero gas is a reference gas used during calibration to zero the instrument. When a zero gas with no hydrocarbon content is introduced to the monitor, the detector will still respond with a small signal. This signal is a result of background ionization. During calibration, zero gas is applied to quantify the background ionization current.

*Zero Gas Recommendations:* The preferred zero gas is hydrocarbon-free air. However, for applications where you are only interested in concentration changes relative to a reference ambient environment, fresh air can be used as the zero gas. When background gas is present, MSA recommends using hydrocarbon-free air to zero the unit. Zeroing the monitor with hydrocarbon-free air reduces the background count, improves response, and decreases the stabilization time required to span the instrument.

### *Span gas*

Span gas is a reference gas used during calibration to determine the slope (response per unit concentration) of the calibrated response curve.

*Span gas Recommendation:* MSA strongly recommends that the span gas used during calibration be well within the concentration range you expect to encounter in the survey area.

### **Response Factors**

When a compound is ionized by a photoionization detector, it yields a current. This response is a characteristic property of the specific compound influenced by its molecular structure. The slope of the response curve (defined in picoamperes per ppm) is different for different chemicals. To properly report the concentration for a given sample gas, the Passport PID II Monitor uses response factors.

The response factor is defined as the ratio of the detector response for isobutylene to the detector response for the sample gas. Response factors to a wide range of substances have been determined experimentally. These response factors are programmed into the instrument. Note that the calibrated response curve, and all programmed response factors are relative to isobutylene. (Isobutylene has a response factor of one.)

The response factor is a multiplier that compensates for the difference between the response of the sample gas and the response of isobutylene. Whenever the monitor detects a signal, it uses the response factor for that chemical to convert the signal to an isobutylene equivalent response. During calibration, this calculation is performed to define the calibrated response curve. When sampling, the isobutylene equivalent response is then multiplied by the response factor for the specific sample gas to calculate the concentration.

If the response factor is known, you can use a monitor calibrated on isobutylene to calculate the actual concentration of a target gas.

For example:

An operator is using a monitor that has been calibrated on isobutylene. The sample gas is set to isobutylene. While using this instrument to sample for hydrogen sulfide ( $\text{H}_2\text{S}$ ), the display reads 100 ppm. Since the response factor for hydrogen sulfide is 6.25, then the actual concentration of hydrogen sulfide is:

$$\text{Actual Hydrogen Sulfide Concentration} = 6.25 \times 100 \text{ ppm} = 625 \text{ ppm.}$$

### **Calculating a Response Factor**

To determine a response factor for a target chemical, perform the following simple procedure:

1. Calibrate the Passport PID II Monitor using isobutylene as the span gas.

2. On the monitor, set the sample gas name to isobutylene.
3. Apply a known concentration of the target chemical to the monitor and note the concentration reported in the display.
4. The response factor for the target chemical relative to isobutylene is:

$$RF_{target\ gas} = \frac{\text{Actual known concentration}}{\text{Concentration reported by instrument}} = 0.55$$

For example:

A monitor is calibrated on isobutylene, and has isobutylene defined as the sample gas. When sampling 110 ppm of benzene in air, the instrument reports a concentration of 200 ppm. In this example, the response factor for benzene relative to isobutylene would be:

$$RF_{benz} = \frac{110\text{ ppm known conc. benzene}}{200\text{ ppm reported}} = 0.55$$

When surveying, if benzene is selected as the sample gas in the Sample Gas page, the instrument would use this response factor to calculate the concentration.

If a chemical has a response factor between zero and one, the monitor has a higher detector response for this chemical than isobutylene. If the response factor is greater than one, the monitor has a lower detector response for this chemical than isobutylene.

## ***Calculating Exposures***

During operation, the monitor detects and calculates the total concentration of photoionizable species in the sample stream at one second intervals. The exposure for each minute of operation is obtained by averaging the one second values. The resulting unit is called a “ppm minute”. The sum of the ppm minute values for a specified time period is then used to calculate your accumulated exposure.

## ***Threshold Limit Values***

The Passport PID II Monitor is designed to detect TWA, STEL and Ceiling alarms as defined by the 1995-1996 Threshold Limit Values for Chemical substances and Physical Agents and Biological Exposure Indices obtained from the Occupational Safety and Health Administration (OSHA) and developed by the American Conference of Governmental Industrial Hygienists (ACGIH.) These definitions are presented below for your reference.

### **Threshold Limit Value-Time Weighted Average (TWA)**

The time-weighted average concentration for a normal 8-hour workday and a 40-hour workweek, to which nearly all workers may be repeatedly exposed, day after day, without adverse effect.

The TWA value reported by the Passport PID Monitor is calculated as:

$$TWA \text{ value} = \frac{(\text{Accumulated minute exposures})(\text{ppm minutes})}{480 \text{ min.}}$$

where:

480 minutes = 8 hours.

Since the TWA calculation always divides by eight hours, the TWA reported on the monitor is a predictive average. For example, if the TWA reading is 11.5 ppm after 7.5 hours, the calculation assumes that you will be exposed to zero ppm for the next 30 minutes. Consider:

$$11.5 \text{ ppm} = \frac{(\text{Average concentration})(450 \text{ min.})}{480 \text{ min.}}$$

In this example, if you wished to solve for the average concentration, then:

$$\text{Ave. concentration for 7.5 hours} = 11.5 \text{ ppm} \cdot \frac{480 \text{ min.}}{450 \text{ min.}} = 12.27 \text{ ppm}$$

### **Threshold Limit Value-Short Term Exposure Limit (STEL)**

The concentration to which workers can be exposed continuously for a short period of time without suffering from 1) irritation, 2) chronic or irreversible tissue damage or 3) narcosis of sufficient degree to increase the likelihood of accidental injury, impair self rescue or materially reduce work efficiency, and provided that daily TLV-TWA is not exceeded. It is not a separate independent exposure limit; rather, it supplements the time weighted average (TWA) limit where there are recognized acute effects from a substance whose toxic effects are primarily of a chronic nature. STELs are recommended only where toxic levels have been reported from high short-term exposures in either humans or animals.

A STEL is defined as a 15-minute TWA exposure that should not be exceeded at any time during a workday even if the 8-hour TWA is within the TLV-TWA. Exposures above the TLV-TWA up to the STEL should not be longer than 15 minutes and should not occur

more than 4 times per day. There should be at least 60 minutes between successive exposures in this range. An averaging period other than 15 minutes may be recommended when this is warranted by observed biological effects.

The STEL value reported by the Passport PID II Monitor is calculated as:

$$STEL\ Value = \frac{\text{Sum of previous minute exposures (ppm minutes)}}{15\ \text{minutes}}$$

For the first 15 minutes of sampling, the STEL is predictive then the STEL value is calculated as above.

### ***Threshold Limit Value-Ceiling (TLV-C)***

The concentration that should not be exceeded during any part of the working exposure.

## Section 2. Safety Information

### 2.1. Warnings

#### **WARNING**

- The Passport PID II Monitor contains a photoionization detector used to detect the presence and quantity of photoionizable species in the sample stream. The instrument must be used to detect only photoionizable gases. Toxic chemicals that cannot be ionized by the detector may be present; however, the Passport PID II Monitor will not detect these chemicals.
- The Passport PID II Monitor does not distinguish between individual chemicals. The reading displayed represents the concentration of all photoionizable species present in the sample. The instrument cannot be used to separate chemicals in a mixture. Care must be taken when interpreting the displayed concentration.
- Repair or alteration of the Passport PID II Monitor beyond the scope of these instructions by anyone other than a person authorized by MSA could cause the monitor to fail to perform as designed. When needed, use only genuine MSA replacement parts. Substitution of components can impair instrument performance, alter the intrinsic safety characteristics, or void agency approvals.
- Use the data port only with MSA approved accessories; otherwise, the intrinsic safety of the instrument may be impaired.
- Moisture, oxygen, and methane, among other compounds, will quench the PID signal causing the instrument to under report concentration readings. This consequence must be understood by personnel operating the instrument.
- When sampling with accessory sampling lines, use the shortest possible length to minimize the time needed to obtain a valid reading.

- When sampling over liquids, do not allow the tip of the sampling probe to touch the surface of the liquid. If liquids enter the instrument, internal damage can result. Further, the presence of liquid in the sample line can obstruct the flow of sample gas, causing the unit to generate inaccurate readings.
- Battery packs must be recharged in a non-hazardous location, free of combustible gases and vapors; otherwise, an explosion can occur.
- A daily calibration check is part of the routine setup procedure for this instrument. Failure to perform a daily calibration check and recalibrate if necessary, can adversely affect the accuracy of concentration readings.

**FAILURE TO FOLLOW THESE WARNINGS CAN  
RESULT IN SERIOUS PERSONAL INJURY OR DEATH.**

---

## 2.2. Cautions

### CAUTION

- Do not connect the sample inlet port to a pressurized gas line, as this will damage the internal pump.
- Do not use sampling lines of a combined length greater than 30 feet.
- Do not operate the monitor without a water trap filter in place. To protect the instrument, a water trap filter must be installed in either the sampling probe or the sample line.
- If you suspect that contaminants have been drawn into the monitor, replace the filters inside the sample probe and the pump module. Prior to operating the monitor, clean the lamp. Operating the instrument with a contaminated probe, lamp, or sample line can cause the monitor to generate inaccurate readings.
- Dispose of exhausted batteries in accordance with all applicable regulations.
- Use only the battery chargers listed in this manual. Use of other battery chargers can result in damage to the battery pack and the instrument.

## Section 3. Using Your Monitor

### 3.1. Physical Description

The Passport PID II Organic Vapor Monitor is a portable gas analyzer equipped with a photoionization detector. The user interface features a liquid crystal display used in conjunction with a three-button keypad. The alarm system consists of the alarm lights located on each side of the display and the alarm horn located between the ON/OFF and RESET buttons.



**Figure 3-1. Passport PID II Organic Vapor Monitor**

When monitoring in a noisy environment, the earphone accessory can be used to directly communicate audible alarms to the operator. The earphone jack is located beneath a protective plug on the side of the unit. A battery pack must be installed to operate the instrument. Alone, the battery pack can provide power for portable applications. Alternatively, the AC adapter/charger accessory can be used with a Type A, or B (heavy-duty) battery pack to power the instrument. The AC adapter plugs into the adapter jack located on the side of the battery pack. A belt-clip located on the bottom of the unit provides hands-free operation of the monitor.

## PID Lamp, Inlet & Outlet Ports

The PID lamp is located in the lamp chamber inside the body of the unit. The lamp chamber is sealed with a cap. To access the lamp for cleaning or maintenance, remove the lamp cap and slide the lamp out of the chamber.

The sample inlet port is located on the back of the instrument. When the instrument is surveying, the sample probe connects to the inlet port, routing gas to the detector manifold for analysis. The outlet vent is located at the center of the star-shaped aperture on top of the instrument.

A capped, RS-232 data port is found on the back of the unit next to the inlet port. Note that the data port is not enabled on the standard unit. The data port, and scanner accessories, are upgrade options for the Passport PID monitor that must be enabled at the factory. When enabled, the dataport provides communication between the monitor and the datalogging scanner accessory.

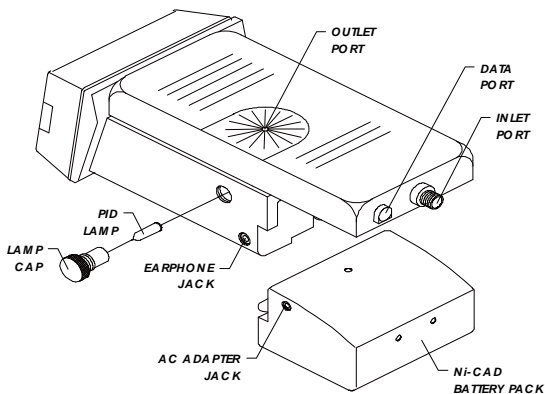

Figure 3-2. Sample Inlet and Data Port

### **! WARNING**



Use the data port only with MSA approved accessories; otherwise, the intrinsic safety of the instrument may be impaired. Failure to follow the above can result in serious personal injury or death.

## 3.2. Instrument Manual

The Passport PID II Monitor performs as designed only when used in accordance with the manufacturer's instructions presented in this manual. Protect yourself and others—use your manual. When used properly, the Passport PID II Monitor will detect the presence and total concentration of photoionizable species. Note that the monitor does not distinguish between individual gases. The reading displayed represents the total concentration of all photoionizable chemicals present in the sample.

### *International Icons*

This manual presents detailed instructions on how to operate the monitor, and perform user approved maintenance procedures. Instructions in the manual use button icons that correspond to the monitor's buttons to indicate which button must be pressed at that step in the procedure.

<b>Button Icon</b>	<b>Button Name</b>
	PAGE
	ON/OFF
	RESET

**Table 3-1. International Icons**

In the software, text sometimes appears on-screen over a button to indicate its function at that point in the software. In the manual, the on-screen text is also included in the instruction, bracketed by parentheses.

### 3.3. Instrument Software

#### Display Page

The monitor uses a software tree to support its monitoring features. The tree is organized into pages that display on the monitor's screen. Each display page supports the unique function provided by the software at that point in the software tree. The monitor's display is formatted so that important information in the Exposure page is presented clearly and consistently.

- **System Status Messages** for battery, lamp or pump alarms appear in the center of the top line of the screen.

- **Monitored Parameters** such as the current concentration, battery voltage and gas name, appear left justified on the top line of the screen.

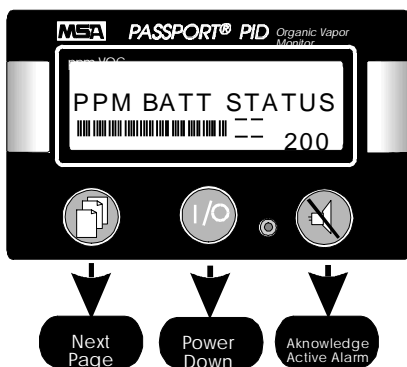

- **Status Messages** for concentration alarms appear right justified on the top line of the screen.

- A **Concentration Bar Graph** on the bottom line of the screen indicates the current concentration. Numbers to the right of the graph indicate the full scale response for the current range.

**Figure 3-3. Exposure Display Page**

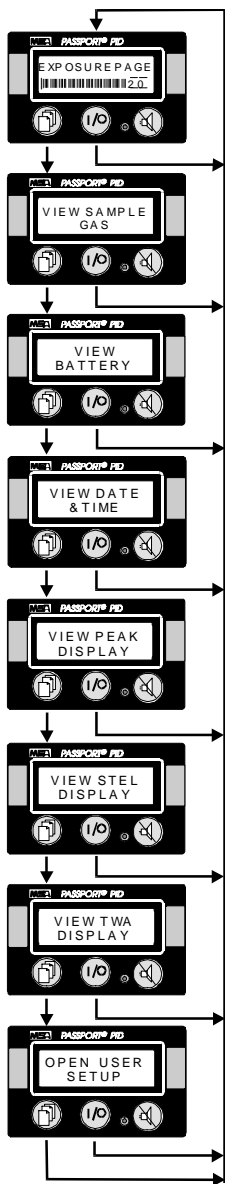

**Figure 3-4. Sequence of Display Pages**

## Instrument Configuration

**Factory Configuration:** When the monitor is shipped from the factory it is configured to sample at ten second intervals and supports all the features shown in figure 3-4.

**Changing the Configuration:** The configuration of the Passport PID II Monitor can be changed to support different applications by enabling or disabling its optional features. This is accomplished by using the Data Logging Software and Data Docking Module with your PC to change or disable the following items:

- Sampling interval (select a ten second interval or a one minute interval).
- Ceiling Alarm feature (ON or OFF)
- Peak Reading feature (ON or OFF)
- STEL Alarm feature (ON or OFF)
- TWA Alarm feature (ON or OFF)
- Data Labeling feature (ON or OFF)

When a feature is disabled, the display page that supports that feature is also turned off. No matter how the instrument is configured, pressing PAGE always opens the *next* display page enabled on the unit.

## Power Saving Mode

During operation, if the faceplate buttons are inactive for 60 seconds, the unit goes into power saving mode. In power saving mode, the display backlight shuts off to conserve battery life. Monitoring and alarm functions are not interrupted. Press any key to reactivate the display backlight.

### 3.4. Preparing for Startup

Prior to operation, the sampling probe must be assembled and attached to the monitor's inlet port, and the battery pack must be installed.

#### *Probe Assembly*

1. Grasp the cap and the base of the probe handle.

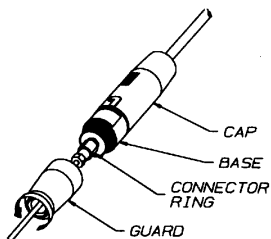

**Figure 3-5. Attaching the Sample Line**

2. Unscrew the lower guard section from the labeled base section.
3. Insert the male end of the sample line through the guard, and screw it into the exposed connector ring on the probe.
4. Screw the guard section back onto the base.
5. Push the cap section toward the base and turn it clockwise to disengage. Separate the cap from the base. Verify that a water trap filter is mounted on the wand as shown in figure 3-6.

#### **⚠ CAUTION**

**Do not operate the monitor without a water trap filter in place. To protect the instrument, a water trap filter must be installed in either the sampling probe or the sample line.**

To install a water trap filter, mount the water trap filter onto the wand as shown in figure 3-6, and reassemble the probe handle.

#### *Connecting the Probe*

1. Connect the quick connect on the sample line to the sample inlet port.

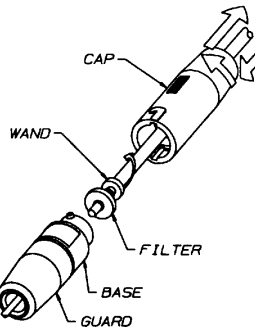

**Figure 3-6. Installing a Water Trap Filter**

### *Installing the Battery Pack*

1. Align the battery pack with the battery contact on the back of the monitor body as shown. Press the battery into the socket. Using a dime or a screwdriver, turn the “quarter-turn fastener” on the bottom of the instrument clockwise to secure the battery pack to the unit.

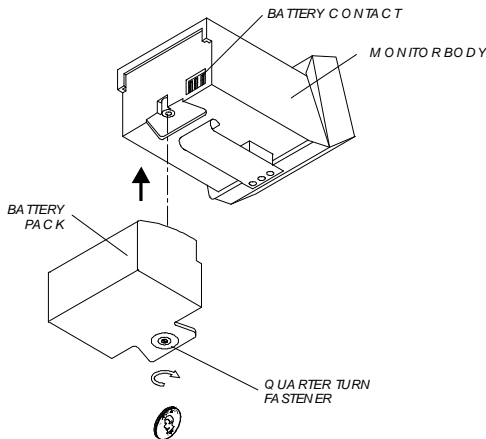

**Figure 3-7. Installing the Battery Pack**

2. When the battery is engaged, the display lights, and the revision level of the operating system software is reported on-screen. Note that the faceplate buttons are disabled while the unit reports its software version and runs self-diagnostic tests.

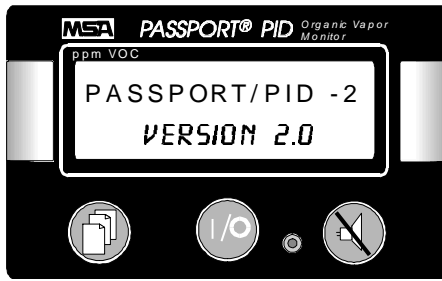

Figure 3-8. Operating System Software Version

**NOTE**

**If your unit does not seem to be operating correctly, be sure to have your software revision number handy before contacting a Service Technician.**

3. A brief system check follows. During this check, the alarm prompts are verified: the display flashes, the alarm horn sounds, and the alarm lights flash. Next, the prompt “SELF TEST: PLEASE WAIT” appears while the electronic components run self-diagnostic tests.



Figure 3-9. Self-Test Display Page

### Self-Test Messages

When the diagnostic tests are completed, the results of the diagnostic are displayed in an on-screen message:

“SELF TEST: ERROR”

This message indicates that the diagnostic tests were not successful, and the alarm sounds.

**NOTE**

If the prompt “SELF TEST: ERROR” appears, turn off the monitor and consult the Troubleshooting Guide found in Section 6, *Cleaning & Routine Care*. Do not use the instrument for protection.

“SELF TEST: OK”

This message indicates that the diagnostic tests were successful.

### Set Date and Time

Following the self-test, the unit reports the current time and date as recorded by the internal system clock.



**Figure 3-10. Date and Time Display Page**

If the date and time are accurate:



Press PAGE (OK) to avoid resetting the system clock.

The alarm sounds, “POWER OFF” displays for a few moments and the instrument shuts down automatically.

### Changing the Date and Time





If the date and time shown in the Date and Time display page are not correct:

1.  Press RESET (CHANGE) to reset the system clock.

This action opens a screen where the time and date can be adjusted. The time and date are divided into five fields, hour, minute, day, month and year. When the time and date selection page opens, the first field “HH” (hour) is highlighted.



**Figure 3-11. Date and Time Selection Page**

2.   Use the PAGE (↓↓) and RESET (↑↑) buttons to set the hour field.
3.  Press ON/OFF (NEXT) to tab to the next field.  
Repeat the procedure, setting the remaining fields as necessary. When the time and date are accurate, press NEXT. Pressing NEXT reopens the Time and Date page.
4.  Press PAGE (OK) to accept the displayed value.  
The alarm sounds, “POWER OFF” displays for a few moments and the instrument shuts down automatically.

### 3.5. Instrument Startup

1.  Press ON/OFF to turn the monitor on.

When the unit is turned on, the system software version number is reported on-screen. Next, the unit runs a brief diagnostic to verify that all systems are functioning properly.

#### NOTE

**If the prompt “SELF TEST: ERROR” appears, turn off the monitor and consult the Troubleshooting Guide found in Section 6, *Cleaning & Routine Care*. Do not use the instrument for protection.**

2. After the self-test is completed, the display reads:

“MEASURE POWER ON”

When this prompt is displayed, the alarm lights and display backlight flash, and the alarm horn sounds.

3. Next, the unit verifies its internal calculations and the status of the PID lamp. During this step the display reads:

“MEASURE PLEASE WAIT”

This final check can take up to thirty seconds to complete. Once this step is completed, the Fresh Air Setup screen opens automatically.

#### NOTE

**In Operational and Setup modes, the instrument is constantly monitoring the status of the PID lamp. If the lamp fails to light during startup, a LAMP system alarm will be issued. See *Resetting a LAMP System Alarm* on page 3-21 for more information about a lamp out alarm.**

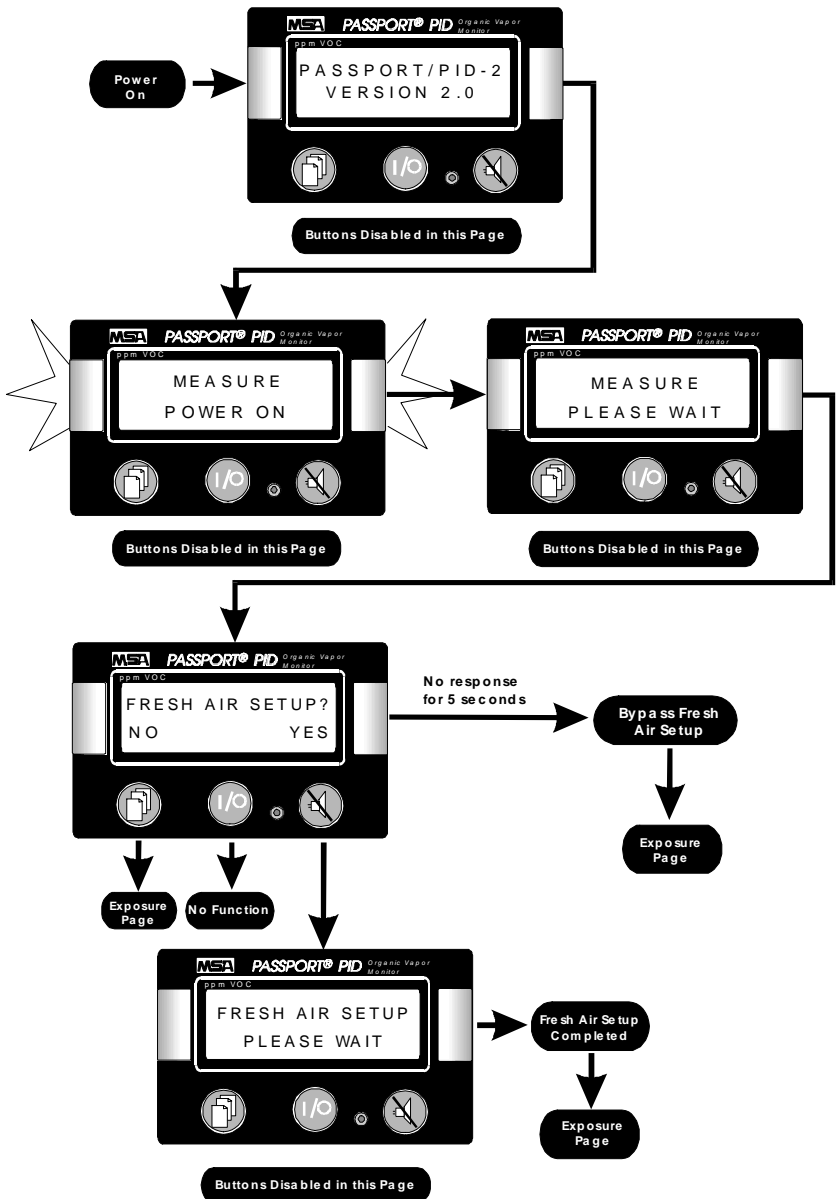

Figure 3-12. Startup Sequence

## Fresh Air Setup

The Fresh Air Setup option allows you to zero the instrument on ambient air.

### NOTE

**The Fresh Air Setup procedure is not a substitute for a complete calibration.**

From the Fresh Air Setup display page, you can initiate or bypass this option. If the unit does not receive a response to the “FRESH AIR SETUP?” query within 5 seconds, fresh air setup is bypassed and the Exposure page opens automatically.

### Perform a Fresh Air Setup



Press RESET (YES) in the Fresh Air Setup page to initiate a fresh air setup. The display responds:

“FRESH AIR SETUP  
PLEASE WAIT”

When the fresh air setup sequence is completed, the display opens the Exposure page automatically. If the fresh air setup cannot be completed, the alarm sounds and the display reports:

“FRESH AIR SETUP  
ERROR--CANCELED”

This message indicates that the fresh air setup attempt was not successful.

### NOTE

**If an ERROR prompt appears, turn off the monitor and consult the Troubleshooting Guide found in Section 6, *Cleaning & Routine Care*. Do not use the instrument for protection.**

### Bypass Fresh Air Setup



Press ON/OFF (NO) to bypass fresh air setup and open the Exposure display page.

### 3.6. Checking the Pump Module

After startup, verify that the pump module is operational:

1. If the unit is not already running, attach the battery and turn the monitor on.
2. Plug the free end of the sampling line or probe. The pump motor shuts down, and the PUMP alarm will sound.
3. Periodically, the pump will try to restart. However, the pump cannot restart until the sampling line is opened. Clear the obstruction in the line. The pump should restart automatically.
4. Press the RESET button to reset the pump alarm.

#### **WARNING**

**When the pump inlet/sample line/probe is blocked, the pump alarm must activate. If the alarm does not activate, there is a leak in the system.**

**Check the pump/sample line/probe for leaks; once the leak is fixed, recheck the pump alarm by blocking the flow. Do not use the repaired pump/sample line/probe unless the pump alarm activates when the flow is blocked. If the pump alarm does not activate, do not use the pump/sample line/probe as the flow of sample to the detector may be impaired or diluted. Inaccurate readings can result and injury or death can occur.**

---

### 3.7. Calibration Check

#### **WARNING**

**A daily calibration check is part of the routine setup procedure for this instrument. Failure to perform a daily calibration check and recalibrate if necessary can adversely affect the accuracy of concentration readings and result in serious personal injury or death.**

---

1. Be sure you are in a fresh air environment. Press ON/OFF to turn on the monitor.
2. When the Exposure page opens, read the concentration displayed on the Passport II PID Monitor.

If the displayed concentration is greater than zero, perform a Fresh Air Setup. Afterwards, verify that the concentration reading in the Exposure page is zero ppm.

3. Attach the regulator to the calibration tubing (diagrammed in figure 5-1).
4. Attach the regulator to the span gas bottle, and attach the calibration tubing to the sample inlet port on the monitor.
5. Open the valve on the regulator. Allow span gas to flow into the instrument for at least thirty seconds, so the unit has sufficient time to stabilize. Note the concentration reported by the monitor. The displayed concentration should be within 5% of the concentration stated on the bottle.

If the span gas reading is not within 5% of the concentration stated on the bottled standard, the Passport II PID Monitor must be calibrated before use.

### 3.8. Exposure Page

The Exposure display page is the monitoring screen where alarm notification takes place, and current concentration values are reported. The Exposure page has two states, **Normal** and **Alarmed**. When the monitor is “on” it continuously detects photoionizable species in the environment no matter what display page is shown. When an alarm condition is detected, the alarm prompts are initiated automatically. Concentration measurements made by the monitor are NOT dependent upon the display of a specific display page.

#### *Time-out Feature*

The Exposure display page is the surveying screen. Note that there is a thirty-second time-out feature associated with all display pages while the instrument is in Survey mode. This feature automatically resets the display to the Exposure page if the faceplate buttons are inactive for thirty seconds.

#### *Normal Exposure Page*

The Normal Exposure page displays the current concentration in the left corner of the screen and a concentration bar graph with range on the bottom line of the screen.

#### *Available Buttons*



Press PAGE to go to the next display page in the software.



Press ON/OFF and hold it down through the five-second countdown to turn off the instrument. If the button is released during the countdown, the shut off command is aborted and the display resets to the Exposure display page.

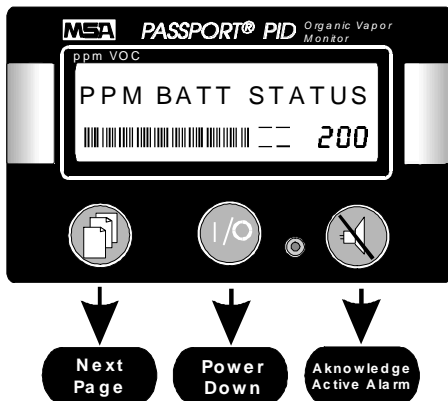

**Figure 3-13. Exposure Page**

### *Analog Bar Graph Display*

The current concentration is indicated by a bar graph displayed in the Exposure display page. The graph displays on the bottom line of the screen. When a concentration is detected, the appropriate area fills to indicate the current concentration.

The full-scale response value for the bar graph is displayed at the right edge of the graph. The bar graph scale is autoranging, and there are five possible values for the full-scale response: 2, 20, 200, 2,000 and 10,000 ppm. When the detected concentration approaches the extreme value for the current range, the graph moves to the next range. The full-scale response value updates automatically to accurately reflect the new concentration range.

### *Alarmed Exposure Page*

The Passport PID II Monitor continuously detects photoionizable species in the atmosphere or in a gas stream. When an alarm condition is detected, the Exposure page becomes “alarmed” and the alarm notification system activates, causing the alarm lights to flash and the alarm horn to sound.

### 3.9. Concentration Alarms

When the unit detects a concentration alarm condition:

- displayed concentration flashes
- alarm horn sounds
- alarm lights flash
- status message appears indicating which alarm threshold was violated.

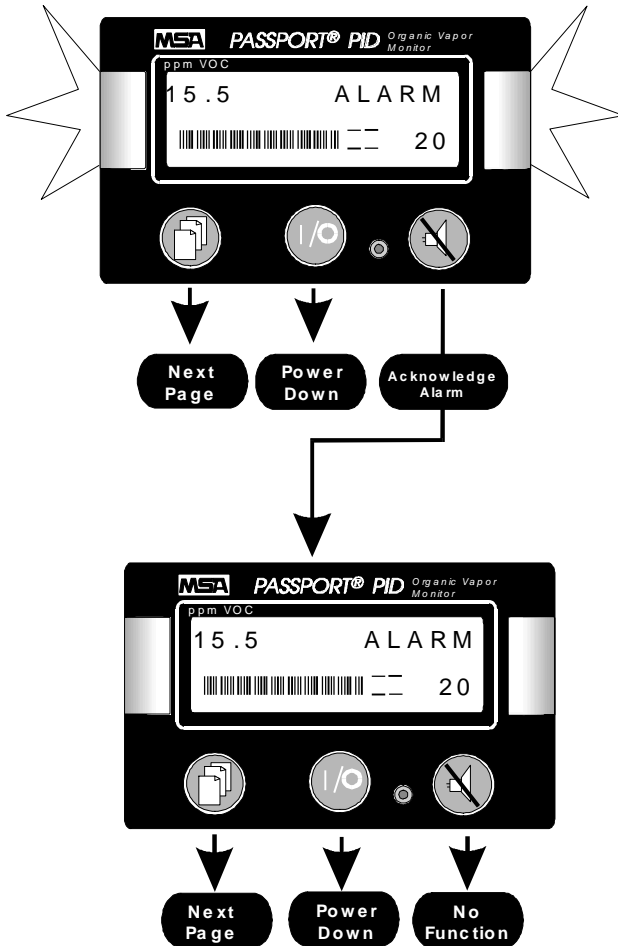

**Figure 3-14. Alarmed Exposure Display – Concentration Alarm**

Status Message	Concentration Alarm Condition
<b>WARN</b>	Indicates a warning level ceiling alarm.
<b>ALARM</b>	Indicates an alarm level ceiling alarm.
<b>STEL</b>	Indicates that the amount of gas detected by the monitor during the current period is greater than or equal to the STEL limit.
<b>TWA</b>	Indicates that the amount of gas detected by the monitor during the current period is greater than or equal to the TWA limit.

**Table 3-2. Status Message and Concentration Alarm Indicated**

### *Resetting a Concentration Alarm*



Press RESET to acknowledge an alarm.

When a concentration alarm is acknowledged, the alarm horn and flashing red lights cease, however, the status message stays on-screen. If the status message is:

“WARN” or “ALARM” Status message cannot be cleared. The status message remains on-screen until the alarm condition is no longer detected. If the alarm condition persists for more than one minute, the alarm notification (alarm lights, alarm horn) will resume.

“STEL” or “TWA” When a STEL or TWA alarm is acknowledged, the status message remains on-screen. The status message can only be cleared if the condition ceases or if the period (STEL, TWA) is reset. Reset the STEL alarm period in the STEL page. Reset the TWA alarm period in the TWA page. If the period is not reset within one minute, the alarm notification (alarm lights, & alarm horn) will resume.

### **3.10. System Alarms**

System alarms indicate that a low battery, obstructed pump or lamp out condition has been detected. When a system alarm occurs:

- alarm horn sounds
- alarm lights flash (pump and lamp alarms only)
- system status message appears indicating the current alarm.

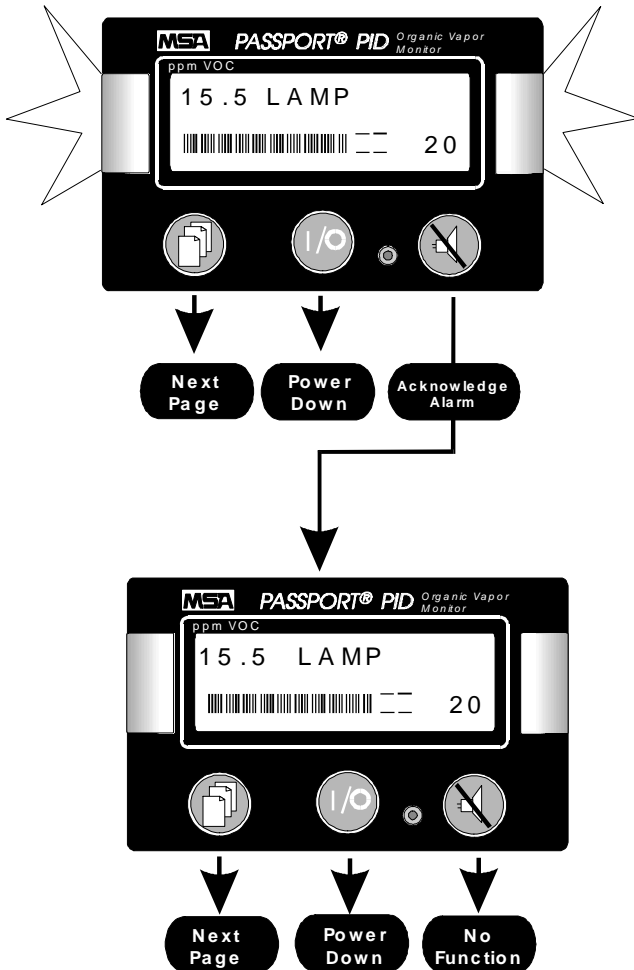

**Figure 3-15. Alarmed Exposure Display-Lamp System Alarm**

Status Message	System Alarm Condition
<b>BATT</b>	Indicates a low battery alarm.
<b>LAMP</b>	Indicates that the PID lamp is out.
<b>PUMP</b>	Indicates that the pump is obstructed.

**Table 3-3. Status Message and System Alarm Indicated**

## BATT System Alarm

If a low battery condition is detected, the alarm horn sounds, and the “BATT” system status message is displayed on-screen.

A BATT alarm indicates that the remaining voltage cannot support the unit for more than a few minutes of continuous operation. When this condition is reached, the status message in the Battery Condition page updates to “LOW” indicating a warning condition.

### Resetting a BATT System Alarm



Press RESET to acknowledge a BATT system alarm.

If the low battery condition is not corrected within one minute, the alarm horn will sound again. A persistent BATT alarm can be reset until the remaining voltage reaches the critical (BATTERY SHUTDOWN) alarm level.

### BATTERY SHUTDOWN System Alarm

When the remaining voltage reaches a critical level, the alarm horn sounds and the alarm lights are lit. The message:

“BATTERY SHUTDOWN”

displays on screen and the display page cannot be changed.

*This alarm cannot be reset.* Automatic shutdown will occur when the remaining voltage can no longer support the battery alarm function.

## WARNING

**If the BATTERY SHUTDOWN alarm sounds:**

- 1. Stop using the instrument, the monitor no longer has enough power to perform alarm functions.**
- 2. Leave the survey area immediately and turn off the instrument.**
- 3. Replace or recharge the battery pack before attempting to operate the unit.**

**Failure to follow this procedure when the BATTERY SHUTDOWN alarm sounds, can result in serious personal injury or death.**

---

## LAMP System Alarm

If the software detects that the lamp is not lit, the alarm horn sounds, the alarm lights flash, and the “LAMP” system status message is displayed on-screen.

### Resetting a LAMP System Alarm



Press RESET to acknowledge a LAMP system alarm.

When the LAMP alarm is acknowledged in the Alarmed Exposure page, the alarm horn and flashing red lights cease, however, the status message cannot be cleared.

If the lamp out condition is not corrected within one minute, the alarm notification (alarm lights & alarm horn) will resume. The alarm will reoccur every minute until the lamp is relit. Once the lamp is lit, the lamp alarm ceases automatically.

### **WARNING**

**If the LAMP alarm sounds:**

- 1. Stop using the instrument, the monitor can no longer detect volatile organic compounds.**
- 2. Leave the survey area immediately and turn off the instrument.**
- 3. Check the lamp cap. It should be finger-tight. (Do not over tighten.) If the lamp alarm persists, do not use the instrument; contact your MSA Service Technician.**

**Failure to follow this procedure when the LAMP alarm sounds can result in serious personal injury or death.**

## PUMP System Alarm

If a pump obstruction is detected, or the power to the pump is interrupted, the alarm horn sounds the alarm lights flash and the “PUMP” system status message is displayed on-screen.

### Resetting a PUMP System Alarm



1. Press RESET to acknowledge a PUMP system alarm.

When a PUMP alarm is acknowledged in the Alarmed Exposure page, the alarm horn and flashing red lights cease, however, the “PUMP” status message remains on-screen.

2. Correct the problem (clear blockage, check electrical connections).



3. Press RESET to clear the “PUMP” status message.

**! WARNING**

**If the PUMP alarm sounds:**

1. **Stop using the instrument, the monitor cannot detect volatile organic compounds if the inlet flow to the pump is obstructed.**
2. **Leave the survey area immediately and turn off the instrument.**
3. **Determine the status of the pump, by performing the following checks:**
  - **Remove the probe and turn on the instrument. If the pump alarm reoccurs, check the pump module filter, and replace if necessary.**
  - **If the pump alarm does not reoccur, check the water trap filter in the sample probe, and replace if necessary.**

**If the PUMP alarm persists, do not use the instrument; contact your Service Technician.**

**Failure to follow this procedure when the pump alarm sounds can result in serious personal injury or death.**

---

### 3.11. Sample Gas Page

The Sample Gas page displays the name of the selected sample gas. The sample gas selection cannot be changed from this screen. The sample gas can only be changed while in User Setup mode.

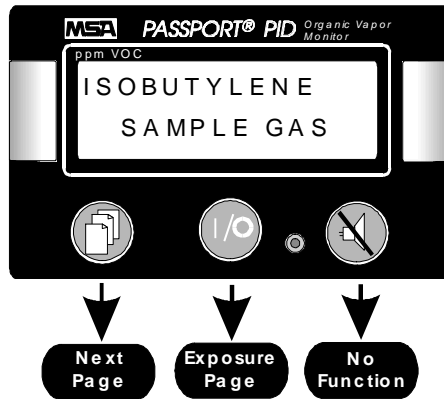

**Figure 3-16. Sample Gas Page**

### 3.12. Battery Condition Page

The Battery Condition page indicates the remaining battery voltage while in survey mode. The remaining battery voltage is a monitored system parameter, and cannot be changed in any screen.

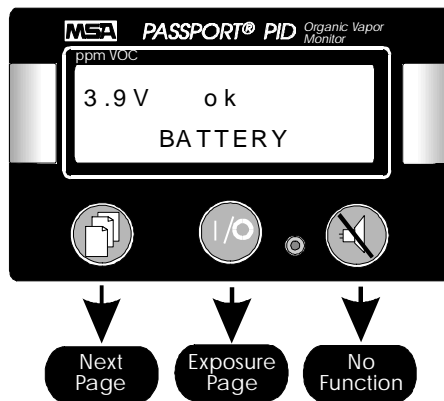

**Figure 3-17. Battery Voltage Page**

#### *Battery System Alarm*

If a battery alarm is active, a status message in the Battery Condition page indicates the current alarm level.

Status Message	Battery Condition
OK	Indicates remaining battery voltage is within an acceptable range.
LOW	Indicates the battery can only operate the unit for a few more minutes of continuous operation.

**Table 3-4. Status Messages and Battery Condition Indicated**

### 3.13. Date and Time Page

The Date and Time page displays the current time as reported by the internal system clock. The date and time can only be changed immediately after the battery is installed as described on page 3-7, or by using the Data Docking Module and Software accessory.

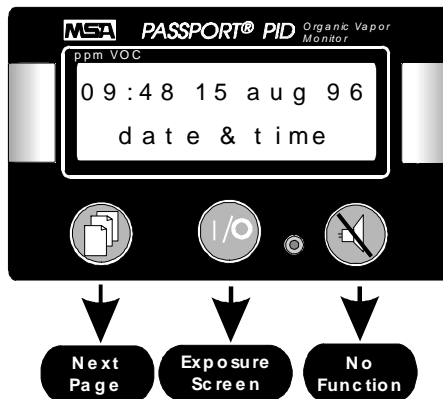
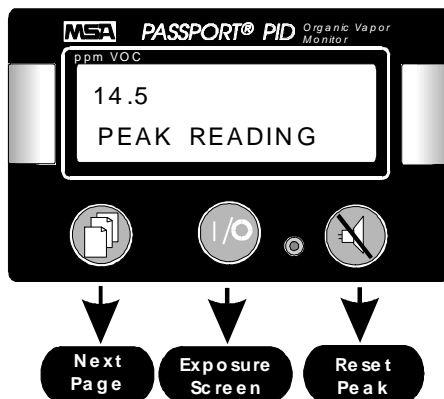

**Figure 3-18. Date and Time Page**

### 3.14. Peak Reading Page

The Peak Reading page indicates the highest concentration of gas detected by the monitor since it was turned on or since the peak reading was reset. The peak reading period can only be reset in the Peak Reading page.

If the Peak Reading feature is enabled (see *Instrument Configuration*, on page 3-5), when the peak reading concentration is greater than or equal to a ceiling alarm threshold (warning or alarm), a concentration alarm is initiated. Text indicating the alarm threshold violated (warning or alarm), will be displayed in the status message area of the Peak Reading page.



**Figure 3-19. Peak Reading Page**

Status Message	Peak Reading Condition
Blank	Indicates that the peak reading displayed is less than the current warning and alarm thresholds.
WARN	Indicates that the peak reading displayed is greater than or equal to the current warning threshold.
ALARM	Indicates that the peak reading displayed is greater than or equal to the current alarm threshold.

**Table 3-5. Status Messages and Peak Reading Condition Indicated**

### *Resetting the Peak Reading*



Press RESET to reset the peak reading to zero. (See figure 3-20.)

#### **NOTE**

**When you turn off the monitor, the peak reading for the current period is cleared from memory. The peak reading period is reset as part of the instrument startup sequence.**

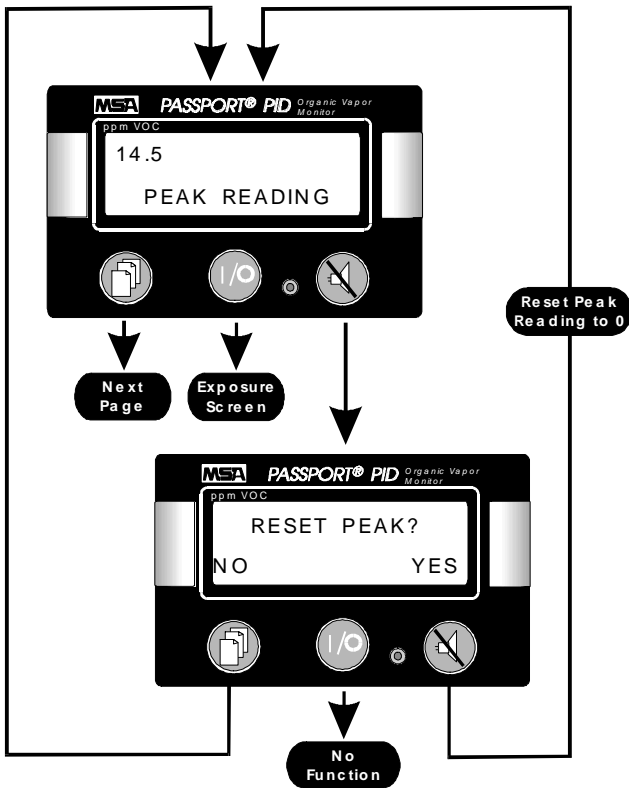

**Figure 3-20. Resetting the Peak Reading**

### 3.15. Short Term Exposure Limit (STEL) Page

A STEL reading is the average exposure over a 15-minute period. The STEL display page (figure 3-21), indicates the current STEL value, and the time elapsed since the current period began. Since the 15 minute STEL period is a rolling window, until 15 minutes have elapsed, the STEL reading is a true TWA for the time elapsed.

The STEL period is set to zero minutes as part of the startup sequence. It can also be reset manually. When the STEL period is reset, the unit begins collecting data for a new 15-minute period. Acknowledged STEL alarms must be reset in the STEL display page.



**Figure 3-21. STEL Page**

Status Message	STEL Condition
Blank	Indicates that the STEL displayed is less than the current STEL alarm threshold.
ALARM	Indicates that the STEL displayed is greater than or equal to the current STEL alarm threshold.

**Table 3-6. Status Messages and STEL Condition Indicated**

### STEL Alarm

If the STEL alarm is enabled (see *Instrument Configuration* on page 3-5), a STEL alarm occurs when the detected concentration is greater than or equal to the STEL alarm level. When a STEL alarm is active, the concentration shown in the upper left corner of the STEL display page flashes, and the Status Message updates to indicate an alarm condition.

### Acknowledging a STEL Alarm



Press RESET in the Alarmed Exposure page to acknowledge an active STEL alarm. The alarm horn and lights cease.

### Resetting a STEL Period

To completely clear an acknowledged alarm, you must reset the STEL period:



Press RESET in the STEL page. The display updates to

“RESET STEL?”

- Press RESET (YES) to start the running count for a new 15-minute STEL period.
- Press PAGE (NO) to avoid resetting the STEL period.

### NOTE

When you turn off the monitor, the STEL and running time for the current period are cleared from memory. The STEL period is reset automatically as part of the instrument startup sequence.

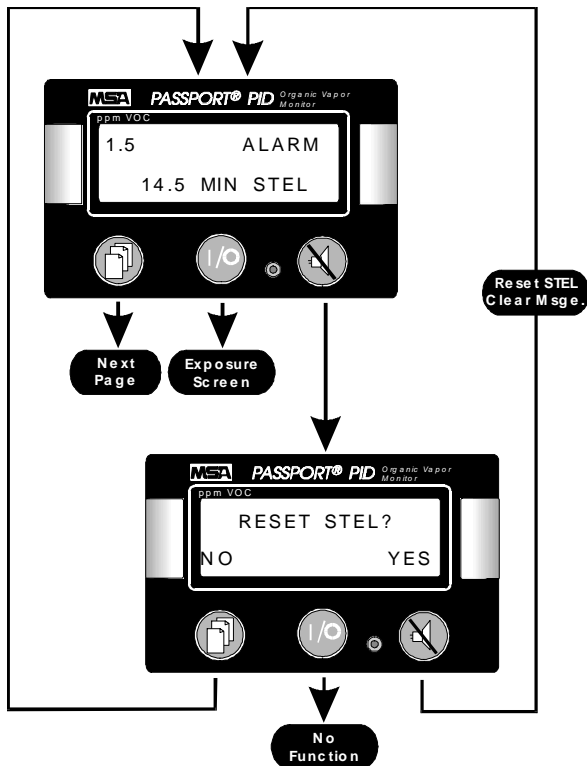
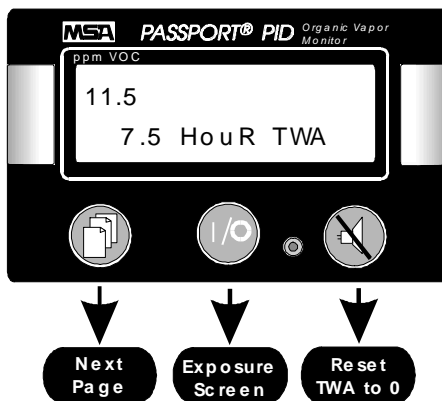

Figure 3-22. Resetting a STEL Alarm

### 3.16. TWA Page

A TWA reading is the average exposure over an 8-hour period. The TWA reading is a true predictive average, this means that the accumulated exposure is always divided by eight hours.

The TWA page indicates the current TWA concentration and time elapsed since the current period began. Acknowledged TWA alarms must be reset in this page.



**Figure 3-23. TWA Page**

Status Messages	TWA Condition
Blank	Indicates that the TWA displayed is less than the current TWA alarm threshold.
ALARM	Indicates that the TWA displayed is greater than or equal to the current TWA alarm threshold.

**Table 3-7. Status Messages and TWA Condition Indicated**

#### *TWA Alarm*

If the TWA alarm is enabled (see *Instrument Configuration* on page 3-5), a TWA alarm occurs when the average concentration of gas detected for the current TWA interval is greater than the eight hour TWA exposure limit. When a TWA alarm is active, the concentration shown in the upper left corner of the TWA display page flashes, and the Status Message updates to indicate an alarm condition.

## Acknowledging a TWA Alarm



Press RESET in the Alarmed Exposure page to acknowledge an active TWA alarm. The alarm horn and lights cease.

## Resetting a TWA Period

To completely clear an acknowledged alarm, you must reset the TWA period:



Press RESET in the TWA page. The display updates to  
“RESET TWA?”

- Press RESET (YES) to start the running count for a new eight hour TWA period.
- Press PAGE (NO) to avoid resetting the TWA period.

### **NOTE**

**The TWA period is not reset as part of the instrument startup sequence. When you turn off the monitor, the TWA and running time for the current period are stored in the monitor's memory. The stored running time and TWA are resumed during the next startup. To clear this information after a startup, reset the TWA period.**

---

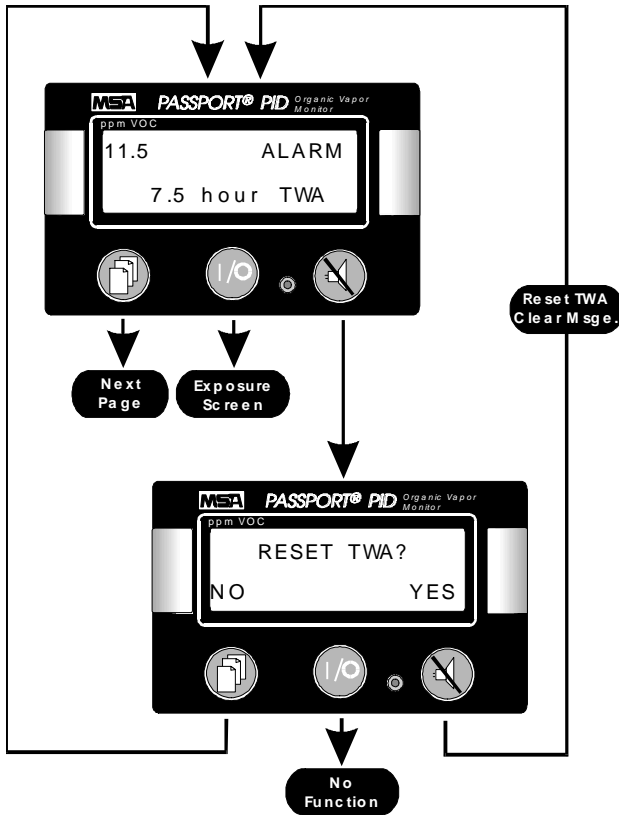

Figure 3-24. Resetting a TWA Alarm

### 3.17. Open User Setup Page

Buttons in the Setup page allow you to put the monitor into User Setup mode. User Setup mode allows you to walk-through the system parameter setup menus, and define the system parameters as necessary for the current application.

#### *Starting Setup Mode*



Press RESET (YES) to initiate User Setup mode.



**Figure 3-25. Open User Setup Page**

### 3.18. Instrument Shut Down



Press ON/OFF in the Exposure display page and hold it down through the five-second countdown to turn off the instrument.

If the button is released during the countdown, the shut off command is aborted and the display resets to the Exposure display page.

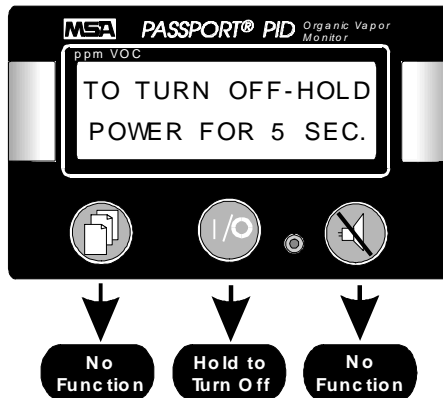

**Figure 3-26. Power Down Page**

## Battery Pack Removal

1. Turn the power off by pressing and holding the ON/OFF button through the five-second countdown.
2. "POWER OFF" appears in the display.
3. Turn the "quarter-turn fastener" on the bottom of the instrument in a counterclockwise direction.
4. Disengage the battery pack by sliding it down and away from the battery contacts as shown in figure 3-27.

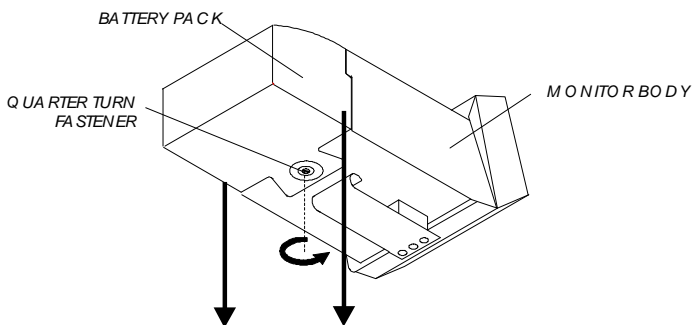

Figure 3-27. Battery Pack Removal

### 3.19 Recharging Nickel-Cadmium (Ni-Cd) Battery Packs

It is not necessary to remove the battery pack from the monitor to charge the battery. The battery pack can be charged alone or while installed on the unit.

1. Plug the charger into an appropriate power source.
2. If the battery pack is attached to the monitor, turn off the instrument.
3. Insert any MSA Omega charger plug into the jack on the battery pack.
4. Be sure the red operating light is on. If the operating light is not on, the battery pack is not being charged.
5. Allow the battery pack to charge undisturbed overnight.

When fully charged, the standard Type A, Ni-Cd battery pack will power the Passport PID II Monitor for eight hours of continuous use at 25<sup>o</sup> C.

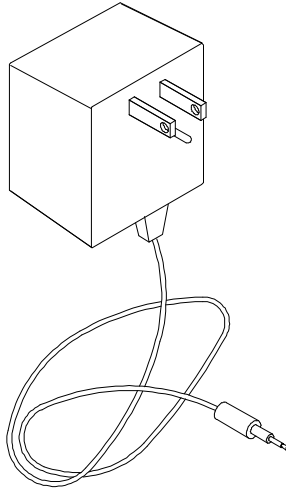

**Figure 3-28. Single Unit MSA Omega Ni-Cd Charger Accessory (U.S. Version)**

## Section 4. Defining the Setup Parameters

### 4.1 Setup Mode Display Pages

#### NOTE





Once you have entered User Setup mode, the display will not automatically return to the Exposure page. To return to the Exposure page from a setup screen, you must press the ON/OFF button. This will reset the monitor to survey mode and open the Exposure page.

### 4.2. Select Sample Gas

In User Setup Mode, the Select Sample Gas page indicates the current sample gas. From this page, you can select the desired gas name from an internal table of 69 gases. When a sample gas name is selected, the response factor associated with that gas is used for all subsequent concentration calculations in all screens.

The contents of the sample gas table are loaded into the unit at the factory. However, up to ten user-defined entries can be added to the sample gas table to support specific applications. These entries can be defined using a personal computer and the Passport Data Docking Module accessory. For assistance loading sample gas names and response factors into the monitor's sample gas table, refer to the *Datalogging Software Instructions* in the module kit.

#### Changing the Sample Gas

1.  Press RESET to change the sample gas. (If you do not wish to change the sample gas, press PAGE to go to the Select Label page.)
2.   Use the PAGE (↓) and RESET (↑) buttons to scroll through the table until the desired sample gas name is displayed.
3.  Press ON/OFF (OK) to enter the new selection.

Note that the sample gas name updates in the Select Sample Gas page. Once a new sample gas is selected, the instrument uses the response factor associated with that gas for all subsequent calculations. Previously stored data is not affected.

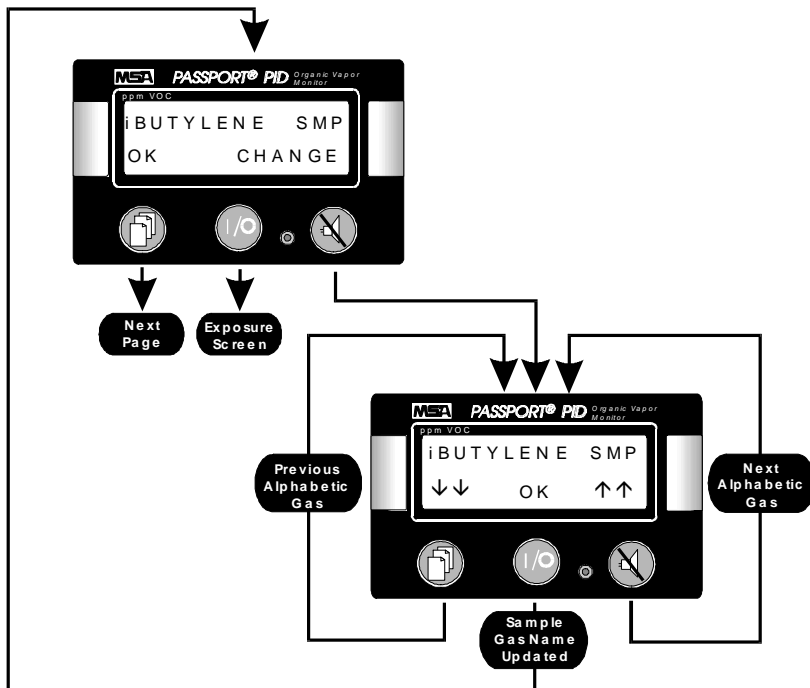

Figure 4-1. Selecting the Sample Gas

#### NOTE





Arrow Up and Arrow Down buttons scroll selections one selection per click or scroll continuously when the button is pressed and held down.

### 4.3. Select Label

The Select Label page supports the data labeling feature. Labels can be used to facilitate report generation by tagging events, or bodies of data. Using the Datalogging Software, stored data and any associated labels can be downloaded to a personal computer for detailed analysis.

Four thousand numeric labels (sequentially numbered 1 to 4000) are defined for the instrument. Once a label is selected, the instrument stores data under that label until it is changed. Previously stored data is not affected.

### Changing the Storage Label

1.  Press RESET to change the label. (If you do not wish to change the label, press PAGE to go to the Select Warning Level page.)
2.   Use the PAGE (↓) and RESET (↑) buttons to scroll through the list until the desired label is displayed.
3.  Press ON/OFF (OK) to enter the new selection.

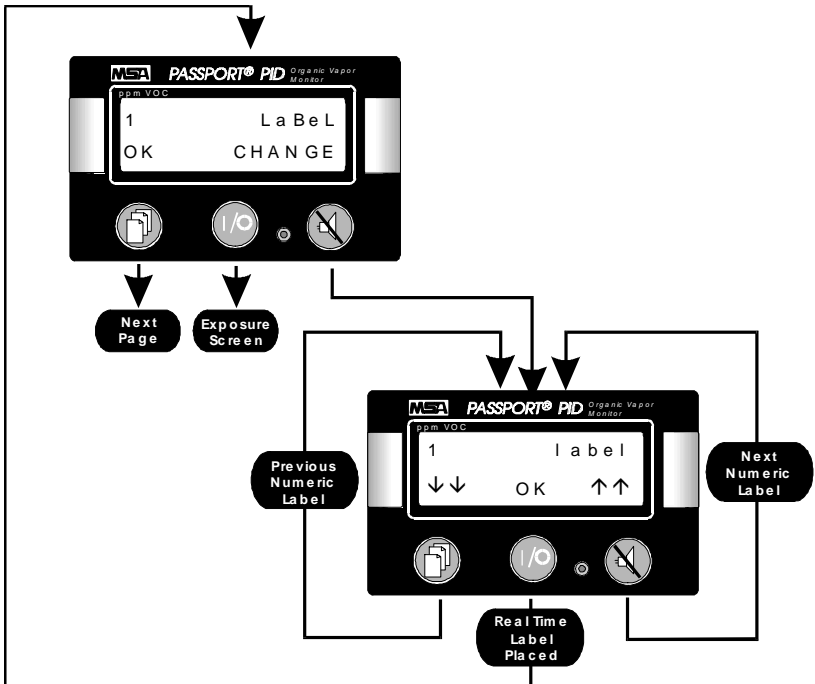





Figure 4-2. Selecting a Storage Label

## 4.4. Select Warning Level

From the Select Warning Level page, you can view or change the *warning* level threshold for the ceiling concentration alarm. The warning and alarm level thresholds represent two distinct levels of alarm.

### *Changing the Warning Level*

-  1. Press RESET to change the warning alarm level. (If you do not wish to change the warning alarm level, press PAGE to go to the Select Alarm Level page.)
-   2. Use the PAGE (↓) and RESET (↑) buttons to adjust the value until the desired warning level threshold is displayed.
-  3. Press ON/OFF (OK) to enter the new selection.  
If the ceiling alarm feature is turned on, the monitor will initiate an alarm whenever the current concentration is greater than or equal to the threshold value selected for the warning level alarm.

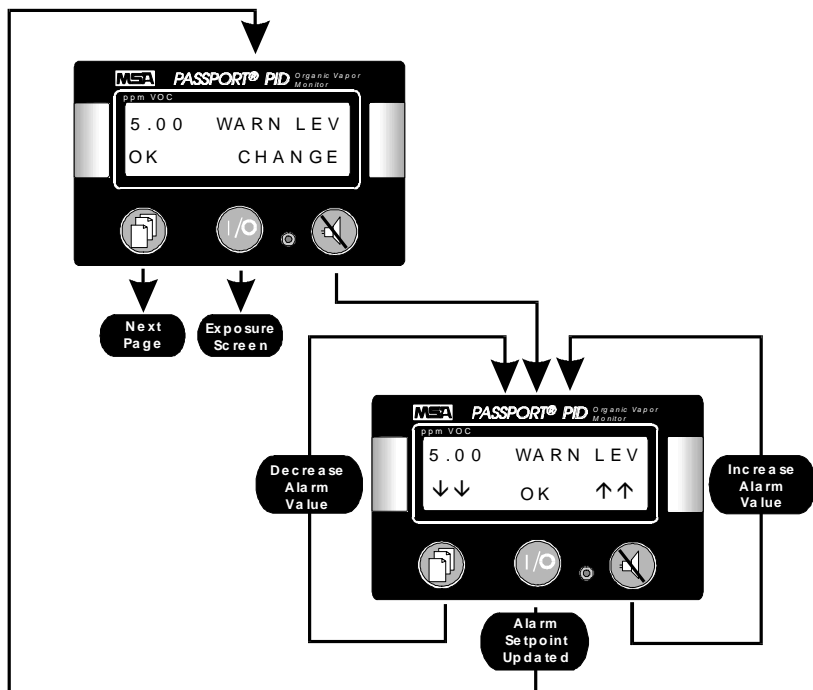





Figure 4-3. Selecting the Warning Level

#### 4.5. Select Alarm Level

From the Select Alarm Level page, you can view or change the *alarm* level threshold for the ceiling concentration alarm.

##### *Changing the Alarm Level*

1.  Press RESET to change the alarm level. (If you do not wish to change the alarm level, press PAGE to go to the Select STEL Level page.)
2.   Use the PAGE (↓↓) and RESET (↑↑) buttons to adjust the value until the desired alarm level threshold is displayed.
3.  Press ON/OFF (OK) to enter the new selection.

If the ceiling alarm feature is turned on, the monitor will initiate an alarm whenever the current concentration is greater than or equal to the threshold value selected for the alarm level.

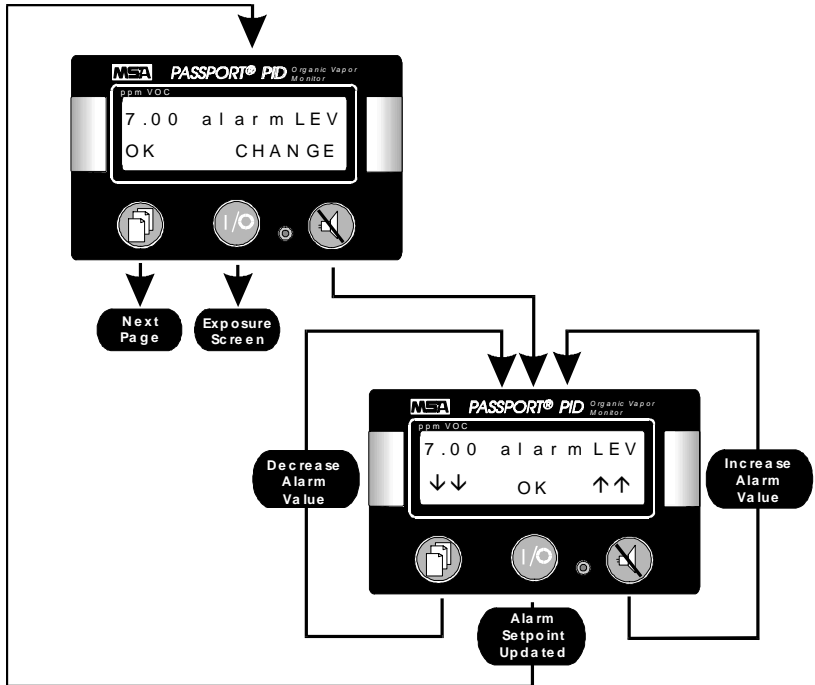





Figure 4-4. Selecting the Alarm Level

#### 4.6. Select STEL Level

From the Select STEL Level page, you can view or change the threshold concentration for the STEL alarm.

##### *Changing the STEL Level*

1.  Press RESET to change the STEL level. (If you do not wish to change the STEL level, press PAGE to go to the Select TWA Level page.)

2.   Use the PAGE (↓↓) and RESET (↑↑) buttons to adjust the value until the desired STEL alarm threshold concentration is displayed.
3.  Press ON/OFF (OK) to enter the new selection.

If the STEL feature is turned on, the monitor will initiate an alarm whenever the current STEL average is greater than or equal to the threshold value selected for the STEL alarm.

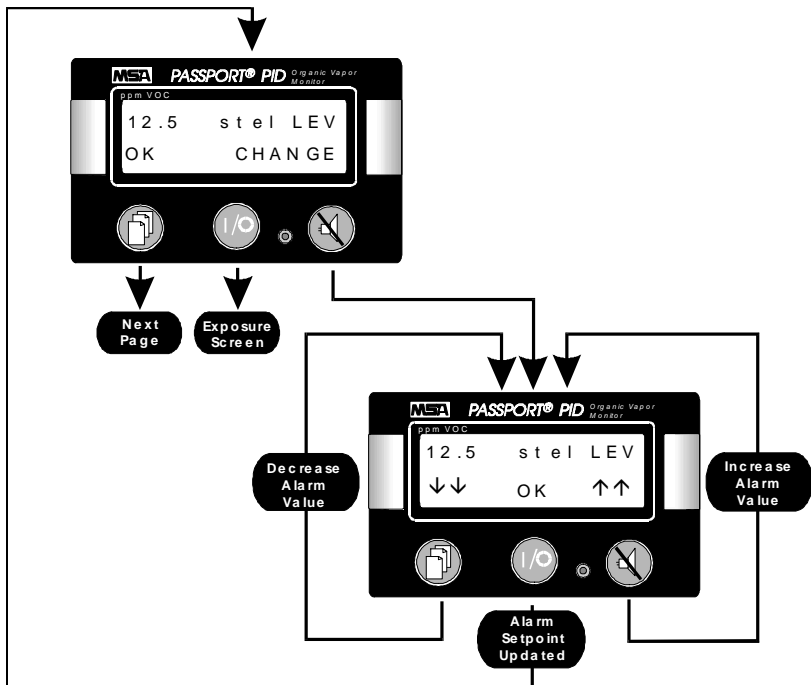





Figure 4-5. Selecting the STEL Level

#### 4.7. Select TWA Level

From the Select TWA Level page, you can view or change the alarm threshold concentration for the TWA alarm.

## Changing the TWA Level

-  Press **RESET** to change the TWA level. (If you do not wish to change the TWA level, press **PAGE** to exit Setup and return to the Exposure page.)
-   Use the **PAGE** ( $\downarrow\downarrow$ ) and **RESET** ( $\uparrow\uparrow$ ) buttons to adjust the value until the desired TWA alarm threshold concentration is displayed.
-  Press **ON/OFF (OK)** to enter the new selection.

If the TWA feature is turned on, the monitor will initiate an alarm whenever the current TWA average is greater than or equal to the threshold value selected for the TWA alarm.

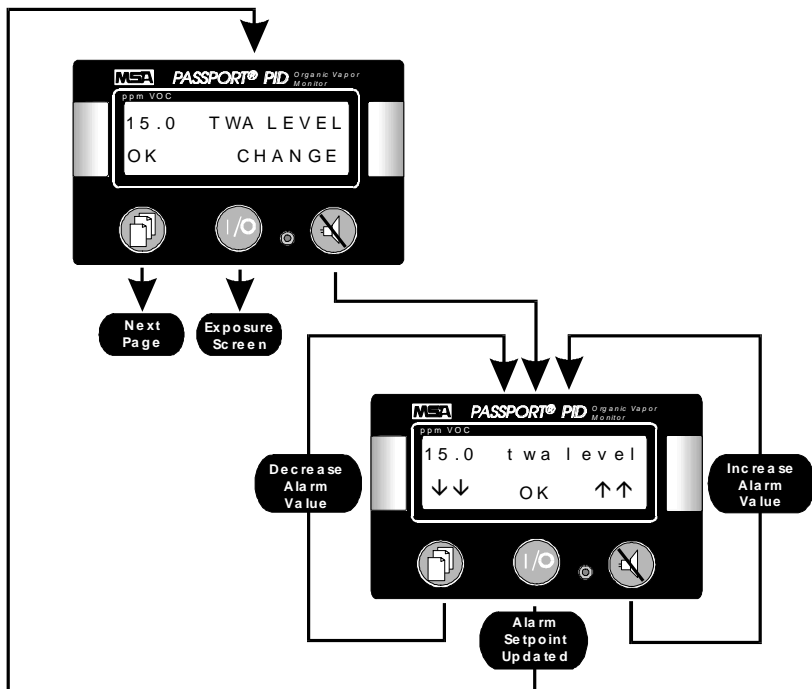

Figure 4-6. Selecting the TWA Level

## Section 5. Calibrating

### 5.1. Calibration

#### **⚠ WARNING**

- A daily calibration check is part of the routine setup procedure for this instrument. Failure to perform a daily calibration check and recalibrate if necessary can adversely affect the accuracy of concentration readings.
- Do not attempt to monitor atmospheric conditions with the unit in calibration mode. The Passport PID II Monitor cannot perform monitoring functions or issue exposure alarms while the calibration is being adjusted. To enable the alarm functions, the monitor must be in survey or setup mode.

**FAILURE TO FOLLOW THESE WARNINGS CAN RESULT IN SERIOUS PERSONAL INJURY OR DEATH.**

### *Calibration Equipment*

The monitor can be easily calibrated for any application using calibration gases of known concentration. To perform a calibration check or calibrate the monitor, you will need calibration tubing and a calibration regulator. Either of the configurations shown in figure 5-1 can be used for these procedures. You will also need bottled calibration standards. The standard span gas for the Passport PID II Monitor is 100 ppm of isobutylene in air.

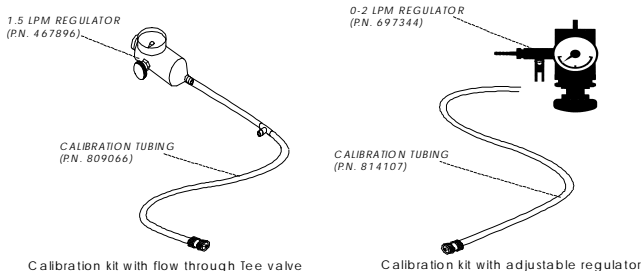

**Figure 5-1. Calibration Equipment**

## 5.2. Calibration Check

1. Be sure you are in a fresh air environment. Press ON/OFF to turn on the Passport PID II Monitor.
2. When the Exposure page opens, read the concentration displayed. If the concentration is greater than zero, perform a Fresh Air Setup. Following the Fresh Air Setup, check the display again to verify that the concentration reading in the Exposure page is zero ppm.
3. Attach the regulator to the calibration tubing as shown in figure 5-1.
4. Attach the regulator to the span gas bottle, and attach the calibration tubing to the sample inlet port on the monitor.
5. Open the valve on the regulator. Allow span gas to flow into the instrument for at least two minutes, so the unit has sufficient time to stabilize. Note the concentration reported by the monitor. The displayed concentration should be within 5% of the concentration stated on the bottle.

If the span gas reading is not within 5% of the concentration stated on the bottled standard, the Passport PID II Monitor must be calibrated before use.

### NOTE

**If the monitor fails a Calibration Check, the PID lamp may need to be cleaned. See subsection 6.5 Maintenance & Technical Procedures for detailed instructions on this procedure.**

---

## 5.3. Calibration Procedure

Figure 5-3 presents the sequence of display pages that support the calibration procedure. Each step in the diagram is documented in the following subsections.

### *Initiate Calibration*

1. If the instrument is running, turn the monitor off. Initiate calibration by simultaneously pressing and holding the PAGE and RESET buttons. While continuing to hold the PAGE and RESET buttons, press the ON/OFF button. Continue to hold the PAGE and RESET buttons until the instrument starts up and the display reads:

"CALIBRATE NOW?"



Figure 5-2. Calibration Screen

2.  Press RESET (YES) to continue. (To skip calibration, press PAGE (NO) and the monitor shuts off automatically.) After RESET (YES) is pressed, the screen displays the message:

“CALIBRATION PLEASE WAIT”

and the Select Calibration Gas page opens (fig. 5-4).

#### NOTE

If the lamp fails to light when the monitor is started in calibration mode, the message “CAL CANCELED LAMP ERROR” appears on-screen, and the unit shuts down. After shut down, check the lamp cap. It should be finger-tight, do not over tighten. Turn the unit on. If the lamp error message persists, turn the unit off, and contact an MSA authorized Service Technician.

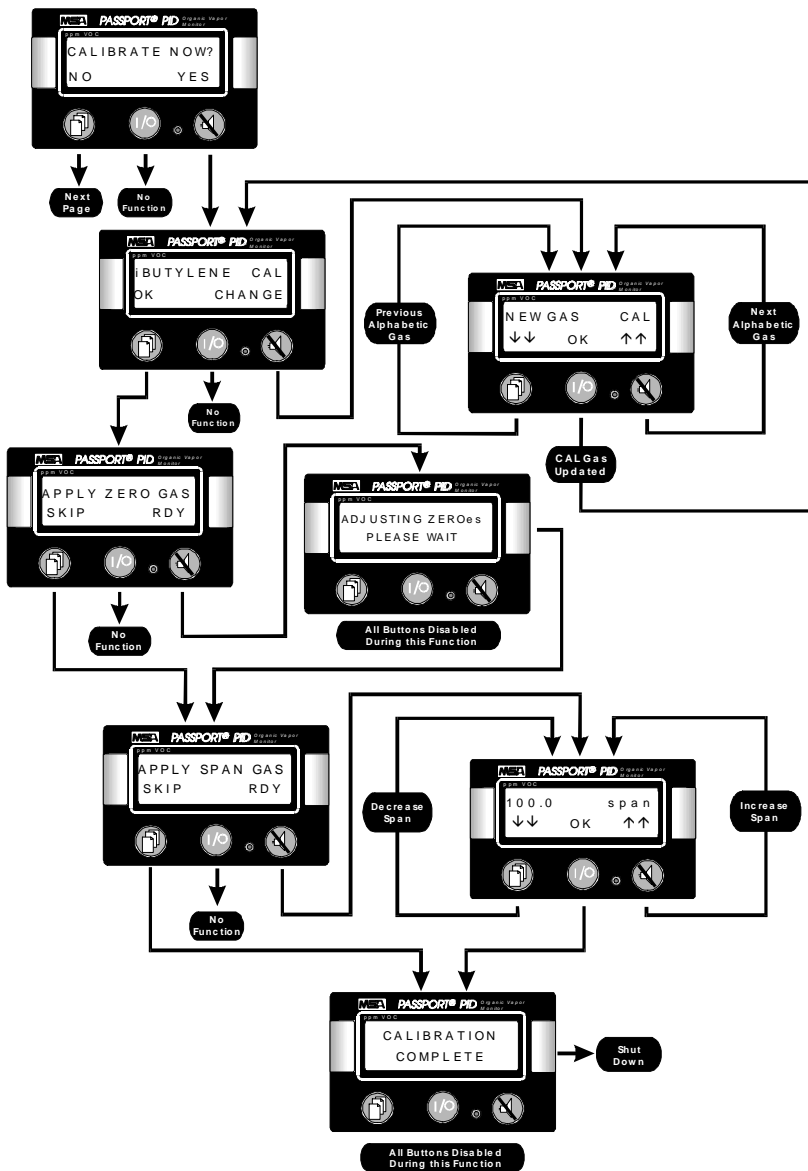
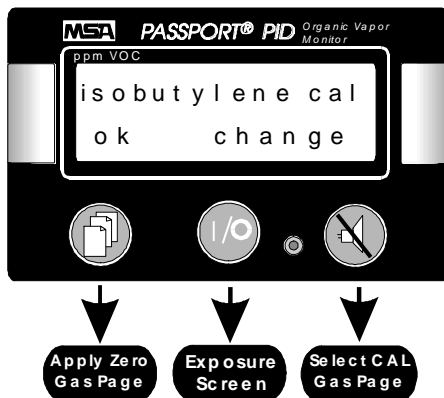

Figure 5-3. Calibration Sequence

## Select the Calibration Gas



**Figure 5-4. Calibration Gas Display Page**

1. Read the current calibration (span) gas name displayed.

If the current calibration gas name is correct:





Press PAGE (OK) to continue.

- To *change* the calibration gas name:



Press RESET (CHANGE) and select the new calibration gas name.

2.  When the calibration gas name accurately reflects this calibration, press ON/OFF (OK) to enter the CAL gas name and reopen the Calibration Gas display page.

3.  Press PAGE (OK) to proceed to the Apply Zero Gas page.

## Applying Zero Gas



**Figure 5-5. Apply Zero Gas Display Page**

1. At the prompt "APPLY ZERO GAS", you must either tell the instrument to zero on fresh air, or attach a bottle of zero gas to the monitor.

- If the zero calibration gas is *fresh* air:



Press RESET (RDY) to zero the instrument.

While the monitor performs its calculations, it displays:

“ADJUSTING ZEROS PLEASE WAIT.”

Following this prompt proceed to step two.

- If the zero calibration gas is *bottled* hydrocarbon-free air:
  - a. Attach the regulator to the calibration tubing (see figure 5-1).
  - b. Attach the regulator to a bottle of hydrocarbon-free zero air.
  - c. Attach the quick connect on the calibration tubing to the sample inlet port.
  - d. Open the valve on the regulator. Allow zero gas to flow into the instrument for at least two minutes.



- e. Press RESET (RDY). The display updates and reads:

“ADJUSTING ZEROS PLEASE WAIT.”

After the zero adjustments are made, the Apply Span Gas display page opens automatically.

## Applying the Span Gas

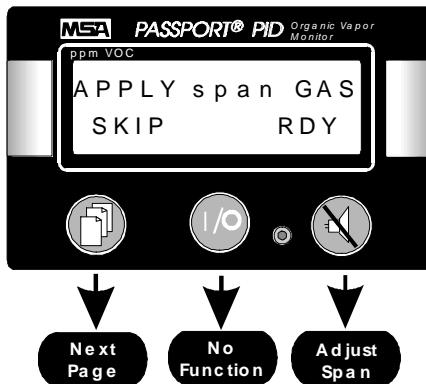

**Figure 5-6. Apply Span Gas Display Page**

To span the instrument:

1. If not already attached in the zero calibration procedure, attach the regulator to the calibration tubing as shown in figure 5-1.
2. Attach the regulator to the span gas bottle.
3. If not already attached in the zero calibration procedure, attach the calibration tubing to the monitor's sample inlet port.
4. Open the valve on the regulator.
5. Press RESET (RDY) to open the Span Gas concentration display page (see figure 5-7). Allow span gas to flow into the instrument for at least two minutes. Monitor the concentration on the instrument until it stabilizes.

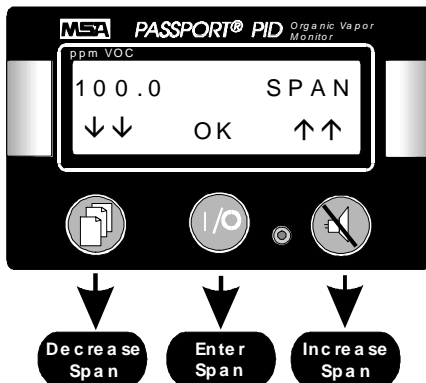

**Figure 5-7. Adjusting the Span Gas Concentration**

- Using the PAGE (↓↓) and RESET (↑↑) buttons, adjust the displayed concentration until it matches the span gas concentration printed on the span gas bottle. When the span gas concentration accurately reflects this calibration:



Press ON/OFF (OK) to enter the reading. The new reading is stored in memory.

- A long beep sounds and the display reads:

“CALIBRATION COMPLETE”

and the unit shuts off automatically.

- After calibrating, attach the sampling probe, turn the unit on and briefly monitor a fresh air environment.

Following a calibration, fresh air should generate a reading of less than one part per million. If the fresh air reading is greater than one ppm, the probe and/or sampling line may be contaminated.

---

**⚠ WARNING**

Operating the instrument with a contaminated probe, pump, or lamp, can cause the monitor to generate inaccurate readings.

If you suspect that contaminants have been drawn into the monitor, remedy the situation by:

- Replacing the water trap filter inside the sample probe.
  - Replacing the pump module filter and frit.
  - Cleaning the PID lamp.
- 

**NOTE**

- During calibration, the displayed reading may appear more unstable than normal. This can occur when the instrument is completely out of calibration with a high gain. If this is the problem, the instability should be corrected by a single calibration. However, a second calibration sequence may be necessary to verify that the instrument is working properly.
  - When using FRESH AIR as the zero calibration gas, during the span sequence, allow span gas flow into the unit for a full two minutes so the instrument has time to stabilize.
-

## Section 6. Cleaning & Routine Care

As with all electronic equipment, the Passport PID II Monitor will operate only if it is cared for and maintained properly.

### **WARNING**

**Repair or alteration of the Passport PID II Organic Vapor Monitor beyond the scope of these instructions by anyone other than a person authorized by MSA could cause the monitor to fail to perform as designed. When needed, use only genuine MSA replacement parts. Substitution of components can impair instrument performance, alter intrinsic safety characteristics, or void agency approvals. Failure to follow the above can result in serious personal injury or death.**

### 6.1. Storage

Store your Passport PID II Monitor in a safe, dry place when it is not in use. Be sure that the storage area temperature is between 32 and 104 degrees Fahrenheit (0 and 40 degrees Celsius). For long term storage, (more than one month) remove the battery pack from the unit.

Clean the monitor's case periodically with a soft cloth dampened with water.

### **WARNING**

**After long term storage, perform a Calibration Check before using the instrument. Failure to do so can adversely affect the accuracy of concentration readings.**

### 6.2. Shipping

Remove the battery pack before shipment. If the Passport PID II Monitor must be returned for service, disconnect the battery pack from the instrument, and ship it with the unit.

Pack the Passport PID II Monitor in its original shipping container with suitable padding. If the original container is unavailable, ask your MSA representative for a replacement. An equivalent container may be substituted if necessary. In either case, seal the instrument in a plastic bag to protect it from moisture. Protect the instrument from the rigors of handling with sufficient padding. Damage due to improper packaging or damage in shipment is not covered by the instrument's warranty.

### **6.3 Technical Support**

The Passport PID II Monitor is a reliable precision instrument when properly maintained. If the instrument displays an error message, or becomes inoperative, leave the survey area immediately and turn off the monitor. Do not use the monitor for protection until the problem is resolved.

The Quick Tab Troubleshooting Guide presented below lists the most probable causes of performance problems and approved corrective actions. If your problem is not addressed in the guide, contact an MSA authorized Service Technician. Be sure to have the monitor's serial number and the software version number handy when calling for technical support.

*Call 1-800-MSA-2222 for Technical Support.*

## 6.4. Quick Tab Troubleshooting Guide

Symptom	Probable Cause	Corrective Action
Unit won't turn on.	Depleted battery pack.	Replace with a charged battery pack.
Battery Pack does not hold a charge.	Bad battery pack.	Replace battery pack.
After battery is installed, unit skips Date & Time Set feature.	Residual power in PID.	Wait two minutes for the power to drain, try again.
"SELF TEST: ERROR" message is displayed when Battery Installed.	Unit did not pass internal diagnostics.	Perform a normal power down, and install battery again. If problem remains, call Technical Support.
"SELF TEST: ERROR" message is displayed at Startup.	Self test did not pass. Unexpected power interruption recorded in the log.	Perform a normal power down, and power up again. If problem remains, call Technical Support.
"FRESH AIR SETUP ERROR-CANCELED" message is displayed at Fresh Air Setup.	The "fresh air" sampled exceeded the hydrocarbon content defined for fresh air, and setup could not be completed.  OR  The hydrocarbon content of the "fresh air" is higher than the span value.	<ul style="list-style-type: none"> <li>- Move to a controlled area with a lower hydrocarbon content, try again.</li> <li>- Be sure the reading for "fresh air" is less than the span value.</li> <li>- Be sure the reading for "fresh air" is not more than 100 ppm higher than the zero value.</li> </ul>
Clock not holding time.	Problem with electronics.	Call Technical Support.
Sample pump not drawing.	Pump obstructed or excessive moisture in line.	Disassemble sample probe, check for water droplets. If found, replace with a dry sample line and new probe particulate trap.
"OUT OF RANGE: KEY IGNORED".	Calibration error.	Recalibrate, and be sure gases are defined correctly.
After calibration, when the probe is attached, the fresh air reading is greater than one ppm.	The probe and/or sampling line may be contaminated.	Replace the filter inside the sample probe particulate trap. After replacement, monitor a fresh air environment. If the fresh air reading has not improved, install a new sampling line.

## 6.5. Maintenance & Technical Procedures

### *Removing and Cleaning the PID Lamp*

Using a lamp that is contaminated with dust, dirt or oily residue can impair the performance of the instrument. Failure to clean the PID lamp can cause inaccurate readings, jeopardizing monitoring functions.

For the most accurate concentration readings, clean the PID lamp after every forty hours of use, or whenever the monitor does not respond acceptably to a calibration check. If you are operating the monitor in a high temperature or high humidity environment, you may need to clean the lamp more than once every 40 hours to maintain optimal performance.

#### **NOTE**

**Thoroughly cleaning the PID lamp as described in this procedure will restore *factory level* performance.**

**This procedure can be performed using only methanol. However, depending on the sampling environment the lamp was subjected to, and the amount of residue on the lamp, a methanol wash may not be as effective as the polishing procedure described in this subsection.**

1. Turn off the monitor and disconnect all power to the unit. Unscrew and remove the lamp cap.
2. Grasp the piece of tubing attached to the tip of the lamp. Pull firmly on the tubing until the lamp pops out of its retaining o-ring.
3. Open the PID Polishing kit (P.N. 812155). The kit consists of cleaning implements, a plastic beaker, a vial of polishing compound, and a bottle of laboratory grade methanol.
4. Pour approximately 30 ml of methanol into the beaker.
5. Moisten a clean cotton swab in the methanol. Dip the damp swab into the polishing compound so the tip is dusted with compound.

#### **NOTE**

**Never dip a used swab into the polishing compound. Doing so will contaminate the vial.**

6. Grasp the lamp securely, and use the swab to polish the lamp by scrubbing it in a firm, circular motion. Polish the lamp lens with the swab for approximately thirty seconds.

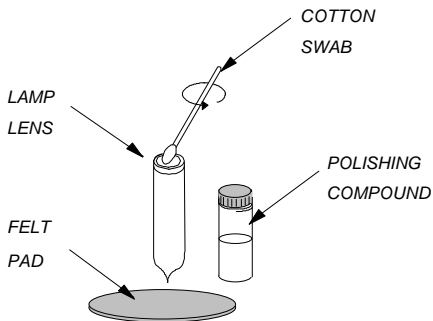

**Figure 6-1. Cleaning the PID Lamp**

7. Using a clean swab, repeat the scrubbing process as described in steps 5 and 6, polishing the lamp for an additional thirty seconds.
8. Once the lens is polished, remove the excess by swishing the lens in the beaker of methanol for at least fifteen seconds. Remove any additional polishing compound by scraping it off the lens with a clean swab.
9. Repeat the methanol rinse with a clean swab as described in step 8.
10. Dry the lamp lens by spraying it with clean, dry pressurized air. Let the lamp air-dry for fifteen minutes. \*To order convenient, portable cans of pressurized air, refer to the list of lamp accessories in Table 6-1.

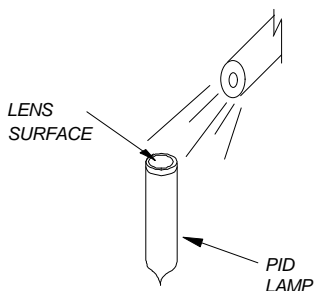

**Figure 6-2. Removing Debris from the PID Lamp**

### NOTE

**Do not use air from an air compressor. Compressed air is not oil-free. Likewise, do not attempt to remove particles from the lens by blowing on it.**

11. Never touch the surface of the lens with your fingers. If accidental contact occurs, repeat the cleaning procedure before installing the lamp. When dry, insert the lamp into the detector housing and allow it to rest against its retaining o-ring. Gently but firmly apply inward pressure on the lamp until it pops back into place.

**NOTE**

**Do not apply excess pressure when seating the lamp. Too much pressure may damage the detector and/or the lamp.**

12. Tighten the lamp cap until it is finger-tight.
13. Turn the monitor on in a fresh air environment and let it run for an hour. This fresh air operating period gives the instrument time to purge any residual methanol from the chamber, and stabilize the background reading.
14. Check the system for leaks by plugging the sample inlet port on the back of the unit with your clean finger. A pump alarm should initiate promptly.
15. Re-calibrate the instrument (see section 5).

### ***Pump Module Replacement***

1. Turn the power OFF and remove the battery pack.
2. Remove any optional sampling equipment.
3. Remove the four screws that mount the pump module.
4. Detach the tubing from the detector and disconnect the RS-232 cable.
5. Lift the pump module away from the instrument.
6. Verify that the pump-to-instrument gasket is in place, and in good condition.
7. Inspect the new pump module. Verify that the pump crank arm on the new module is centered on the pump eccentric bearing. (Equal amounts of bearing should show on either side of the crank arm.)
8. Install the new pump module, making sure that the module is well seated in the gasket.
9. Reattach the RS-232 cable and the detector tubing.
10. Secure the pump module in position with the four mounting screws, and tighten the screws until there is no visible gap between the pump module and the instrument case. Do not over-tighten the screws.
11. Verify that the new pump is operational by attempting to initiate a pump alarm as described in Subsection 3.6 of this manual: *Checking the Pump Module*.

---

## ***Pump Board Replacement***

1. Remove the pump module (described above in steps 1 to 5 of the *Pump Module Replacement* procedure).
2. Unplug the motor connector.
3. Remove the two silicone gasket collars from the board posts.
4. Tilt the pump board up and away from the motor at a 45-degree angle.
5. Unplug the pressure switch from the sockets on the pump board.
6. Plug the pressure switch into the new pump board.
7. Set the pump board fully into the case, making sure not to pinch the pressure switch tubing.
8. Connect the motor connector.
9. Replace the two silicone collars onto their posts.
10. Reattach the RS-232 cable and the detector tubing.
11. Reinstall the pump module.
12. Secure the pump module in position with the four mounting screws, and tighten the screws until there is no visible gap between the pump module and the instrument case. Do not over-tighten the screws.
13. Verify that the new pump is operational by attempting to initiate a pump alarm as described in Subsection 3.6 of this manual: *Checking the Pump Module*.

## ***Pump & Drive Replacement***

1. Remove the pump module (described above in steps 1 to 5 of the *Pump Module Replacement* procedure).
2. Unplug the motor connector.
3. Remove the two silicone gasket collars from the board posts.
4. Remove the pump board.
5. Remove the two screws on the pump mounting collar located nearest the connector end of the motor.
6. Slide the tubing off of the pump block to remove the pump and drive module.
7. Attach tubing to the new pump and drive module.
8. Secure the pump and drive module in place with the two screws and mounting collar; do not over-tighten the screws.
9. Replace the pump board and silicone gaskets.
10. Reconnect the motor connector.
11. Verify that the crank arm of the pump is approximately centered on the eccentric bearing (equal amounts of bearing should show on either side of the bearing).
12. Reattach the RS-232 cable and the detector tubing.

13. Reinstall the pump module.
14. Secure the pump module in position with the four mounting screws, and tighten the screws until there is no visible gap between the pump module and the instrument case. Do not over-tighten the screws.
15. Verify that the new pump is operational by attempting to initiate a pump alarm as described in Subsection 3.6 of this manual: *Checking the Pump Module*.

### ***Pump Motor Replacement***

1. Remove the pump and drive module (described above in steps 1 to 6 in the *Pump & Drive Replacement Procedure*).
2. Loosen the pump frame clamping screw.
3. Slide the motor with attached eccentric and bearing from the frame.
4. If the eccentric and bearing are to be used again, remove them from the motor shaft by prying lightly with a small screwdriver. (*Push only on the plastic eccentric, never on the bearing.*)
5. Press the eccentric and bearing completely onto the new motor shaft. (The end of the motor shaft should be flush with the end of the eccentric.)
6. Slide the motor into the frame and press the crank arm onto the bearing. The crank arm must be centered on the bearings with equal amounts of bearing showing on either side of the crank arm. A .030" spacer or feeler gauge can be used to properly position the crank arm from the flat surface on the eccentric.
7. Use a small ruler or straight edge to adjust the motor so that the end is flush with the rounded pillars on the frame and the motor terminals are straight up and down; then, tighten the clamp screw.
8. Reinstall the pump and drive module, pump board and manifold into the pump case.
9. Reinstall the pump module.
10. Verify that the new pump is operational by attempting to initiate a pump alarm as described in Subsection 3.6 of this manual: *Checking the Pump Module*. The pump should draw a minimum of 240 ml/minute against a resistance of 30 inches of water suction.

### ***Rebuilding the Pump & Drive***

1. Remove the pump and drive module.
2. Remove the motor with attached eccentric and bearing.
3. Remove the four screws that attach the pump plate, gasket and pump block to the plastic frame.
4. Remove the pump block and diaphragm assemblies.

5. Place the new diaphragm and block assemblies on the frame. (The crank arm supplied with the rebuilding kit is marked with a black dot; align the crank arm so that the side with the dot faces the motor. Align the block so the arrow points toward the motor.)
6. Place the gasket and plate on the pump block, and loosely attach these parts to the pump frame with the four screws.
7. Slide the motor into the frame and press the crank arm onto the bearing. The crank arm must be centered on the bearing so equal amounts of bearing can be seen on either side of the crank arm. A .030" spacer or feeler gauge can be used to properly position the crank arm from the flat surface of the eccentric.
8. Use a small ruler or straight edge to adjust the motor so that the end is flush with the rounded pillars on the frame and the motor terminals are straight up and down; then, tighten the clamp screw.
9. Make sure the diaphragm is free to "find" its optimum position; then, press the plate toward the frame and tighten the four screws sequentially and evenly. Do not over-tighten the screws.
10. Any time a pump and drive is disassembled and reassembled, proper operation must be verified. The pump should draw a minimum of 240 ml/minute against a resistance of 30 inches of water suction.

### ***Main Board Replacement***

Before handling the PC boards, ensure you are properly grounded; otherwise, static charges from your body could damage the electronics. Such damage is not covered by the warranty. Grounding straps are available from any electronics supply shop.

1. Turn the power OFF, and remove the battery pack.
2. Remove the lamp cap and lamp, and store in a clean, dry area.
3. Remove the Pump Module (described above in steps 1 through 5 of the *Pump Module Replacement* procedure).
4. Remove the tubing from the detector and disconnect the RS-232 cable.
5. Remove the "hold-down" screw and the back screw.
6. Slide the chassis halfway out of the case.
7. Disconnect the earphone connector.
8. Completely slide the chassis out of the case.

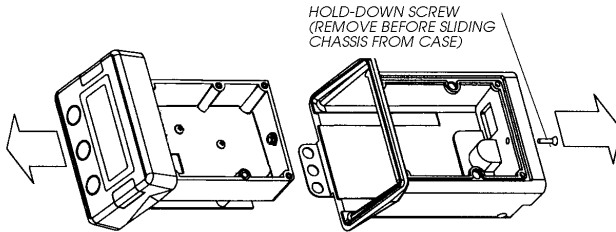

**Figure 6-3. Removing the Chassis**

9. Remove the four main electronics board mounting screws.
10. Turn the instrument over, and lift the main board up to a 45-degree angle; disconnect the power connector.

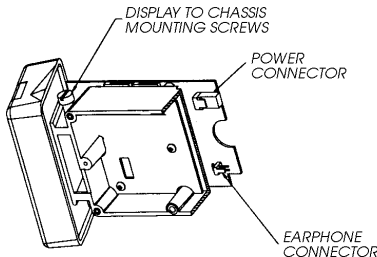

**Figure 6-4. Location of Mounting Screws & Power Connector**

11. Lift up the board up to approximately 90 degrees, and remove the interconnect board and the keypad connector.
12. Remove the board.
13. Set the switches on the new main electronics board to the same positions as those set on the old main electronics board.
14. Insert the new main electronics board.
15. Connect the interconnect board and the keypad connector.
16. Connect the power connector.
17. Fasten the four module-board mounting screws.
18. Slide the chassis halfway into the case.
19. Connect the earphone connector.

20. Slide the chassis completely into the case.
21. Replace the "hold-down" screw and back screw.
22. Install the pump module, and reattach the RS-232 cable and the detector tubing.
23. Clean, and reinstall the PID lamp. Replace the lamp cap.
24. Replace the battery pack.
25. Perform a complete calibration of the Passport PID II Monitor.
26. Verify the alarm set points, adjust if necessary.

### ***Display Module Replacement***

1. Turn the power OFF, and remove the battery pack.
2. Remove the lamp cap and lamp, and store in a clean, dry area.
3. Remove the Pump Module (described above in steps 1 through 5 of the *Pump Module Replacement* procedure).
4. Detach the tubing from the detector and disconnect the RS-232 cable.
5. Remove the "hold-down" screw, and the back screw.
6. Slide the chassis halfway out of the case.
7. Disconnect the earphone connector.
8. Completely slide the chassis out of the case.
9. Turn the instrument over, and remove the four mounting screws.
10. Lift the main board up to a 45-degree angle; disconnect the power connector. (See figure 3-4.)
11. Lift the main board up to approximately 90 degrees, and remove the interconnect board and the keypad connector.
12. Remove the two screws holding the display to the chassis. Remove the four screws holding the display module to the face piece.
13. Remove the display module.
14. Install the new display module.
15. Fasten the display mounting screws.
16. Connect the keypad connector and the interconnect board.
17. Connect the power connector.
18. Replace the four module mounting screws.
19. Slide the chassis halfway into the case.
20. Connect the earphone connector.
21. Slide the chassis completely into the case.
22. Replace the "hold-down" screw, and the back screw.
23. Clean, and reinstall the PID lamp. Replace the lamp cap.
24. Install the pump module. Reattach the RS-232 cable and the detector tubing.
25. Replace the battery pack.
26. Perform a complete calibration of the Passport PID II Monitor.

## Section 7. Appendices

Appendix A: Response Factor Table

ABBREVIATED NAME†	CHEMICAL NAME	RESPONSE FACTOR
1,4-DIOXANE	1,4-DIOXANE	1.48
1-BUTANOL	1-BUTANOL	6.02
1-PROPANOL	1-PROPANOL	11.69
123(CH3)C6H5	1,2,3-TRIMETHYLBENZENE	0.49
124(CH3)C6H5	1,2,4-TRIMETHYLBENZENE	0.43
12C2H2BR2	1,2-DIBROMOETHANE	11.66
12CL2C6H6	1,2-DICHLOROBENZENE	0.62
135(CH3)C6H5	1,3,5-TRIMETHYLBENZENE	0.34
1MTHO2PROPOL	1-METHOXY-2-PROPANOL	1.85
1XACETATE	METHYLACETATE	8.50
1XACRYLAC	METHYLACRYLATE	8.21
1XACTOACETAT	METHYLACETOACETATE	1.30
1XBENZOATE	METHYLBENZOATE	0.93
1XMTHACRYLAT	METHYLMETHACRYLATE	2.20
2-BUTANONE	2-BUTANONE	0.90
2-PENTANONE	2-PENTANONE	0.87
2-PROPANOL	2-PROPANOL	8.35
2MTHOXYETOH	2-METHOXYETHANOL	3.64
2XFORMAMIDE	N,N-DIMETHYLFORMAMIDE	1.13
2XMTACETAMID	N,N-DIMETHYLACETOAMIDE	0.66
4HYD4MTH2PNT	4-HYDROXY-4-METHYL-2-PENTANONE	0.73
ACETONE	ACETONE	1.24
ACETOPHENONE	ACETOPHENONE	0.59
AMYL ACETATE	AMYL ACETATE	5.31
BENZENE	BENZENE	0.55
BROMOMETHANE	BROMOMETHANE	2.72
BUTADIENE	BUTADIENE	0.69
BUTYLACETATE	BUTYLACETATE	8.03
C2CL4	TETRACHLOROETHYLENE	0.60
C2HCL3	TRICHLOROETHYLENE	0.69
C2H4CL2	DICHLOROETHANE	12.33
(C2H5)C6H5	ETHYLBENZENE	0.62
C6H10O3	ETHYLACETOACETATE	1.14
CHLOROBENZEN	CHLOROBENZENE	0.49
CUMENE	CUMENE	0.54
CYCLOHEXANE	CYCLOHEXANE	1.54
CYCLOHEXANON	CYCLOHEXANONE	0.82
DECANE	DECANE	3.66
ABBREVIATED NAME†	CHEMICAL NAME	RESPONSE FACTOR
DIETHYLAMINE	DIETHYLAMINE	0.89
DIMETHOXMETH	DIMETHOXYMETHANE	11.27

ETHYGLYCOL	ETHYLENEGLYCOL	15.30
ETHYLACETATE	ETHYLACETATE	5.68
ETHYLENE	ETHYLENE	10.20
HEPTANE	HEPTANE	4.46
HEXANE	HEXANE	6.23
IAMYLACETATE	ISOAMYLACETATE	6.06
IPROPYLAMINE	ISOPROPYL AMINE	1.28
IPROPYLETHER	ISOPROPYL ETHER	0.84
ISOBUTANOL	ISOBUTANOL	4.99
ISOBUTYLENE	ISOBUTYLENE	1.00
ISOOCTANE	ISOOCTANE	1.86
ISOPHORONE	ISOPHORONE	0.74
M-XYLENE	META-XYLENE	0.45
MESITYLOXIDE	MESITYLOXIDE	0.54
MIBK	METHYL ISOBUTYL KETONE	1.21
MTBE	METHYL TERTIARY BUTYLETHER	0.89
O-XYLENE	ORTHO-XYLENE	0.54
OCTANE	OCTANE	2.71
P-XYLENE	PARA-XYLENE	0.47
PHOSPHINE	PHOSPHINE	3.02
PROPYLENE	PROPYLENE	1.41
PROPYOX	PROPYLENE OXIDE	16.02
PYRIDINE	PYRIDINE	0.78
QUINOLINE	QUINOLINE	0.97
T-BUTYLAMINE	TERTIARY BUTYLAMINE	1.01
T-CLC2H2CL	TRISDICHLOROETHENE	0.45
THF	TETRAHYDROFURAN	2.06
THIOPHENE	THIOPHENE	0.41
TOLUENE	TOLUENE	0.54

† As it appears in the Sample Gas display page. Note that an “X” in the abbreviated name indicates the word “METHYL”.

## **WARNING**

Response factors apply in the 0-500 ppm range and are accurate to  $\pm 25\%$ . The values in this table were obtained using dry bottled gases. These response factors apply only to 10.6 eV lamps. They are not valid for instruments using PID lamps at any other energy. Using these response factors with a lamp at any other energy will critically compromise the instrument's ability to detect organic compounds.

## Appendix B: Additional Response Factors

### **Measurement of ammonia, 1,4-Butanediol, ethylene oxide or, other substances having a response factor greater than 15.99.**

When using the Passport PID II Monitor for ammonia, 1,4-Butanediol, ethylene oxide or, other substances having a response factor greater than the instrument limit of 15.99, it is recommended that the user calibrate the instrument with the gas of interest. If that approach is not feasible, the user must interpolate the reading in order to determine the actual concentration of the substance present. That is, the user must multiply the displayed reading by another factor to compensate for the lower response factor for which the instrument must be set. It is important that users correctly interpret the readings obtained, as the displayed reading will be lower than the actual concentration present.

#### An Ethylene Oxide Example:

An MSA PID instrument calibrated with 100-ppm isobutylene has a response factor for ethylene oxide of 21.28. However, the highest response factor that can be programmed into the PID is 15.99. Therefore, when the PID is calibrated with isobutylene and the sample gas page is set to read ppm ethylene oxide, the most accurate indication of ethylene oxide concentration can be obtained by setting the instrument response factor to 15.99 and multiplying the instrument reading by 1.33. However, some users may find it easier to set the instrument response factor to one half (10.64) of the actual response factor and multiply the displayed value by 2.

#### An Ammonia Example:

An MSA PID instrument calibrated with 100-ppm isobutylene has a response factor for ammonia of 16.62. However, the highest response factor that can be programmed into the PID is 15.99. Therefore, when the PID is calibrated with isobutylene and the sample gas page is set to read ppm ammonia, a more accurate indication of ammonia concentration can be obtained by setting the instrument response factor to 15.99 and multiplying the instrument reading by 1.04. However, some users may find it easier to set the instrument response factor to one half (8.31) of the actual response factor for ammonia and multiply the displayed value by 2.

As stated above, it is recommended that when using an MSA PID instrument for monitoring compounds with response factors in excess of 15.99, the instrument be calibrated with the compound of interest to avoid the need to use a secondary factor to determine the actual concentration.

Contact MSA Customer Service at 1-800-MSA-2222 with any question regarding the above information.

The additional response factors listed here in Appendix B have been determined by MSA Chemists using the Passport PID II Monitor. The listing consists of response factors for several common industrial chemicals that are not preprogrammed into the instrument.

Using your IBM compatible PC with the Data Logging Software and Data Docking Module, you can add a response factor from this listing to the monitor's internal gas table. Consult the Passport PID Data Logging Software User's Manual for specific instructions.

CHEMICAL NAME	RESPONSE FACTOR
ACETALDEHYDE	11.00
ALLYL ALCOHOL	2.92
AMMONIA	16.62
1,4-BUTANEDIOL	37.20
BUTOXYETHANOL	1.44
DIMETHYLFORMAMIDE	1.10
EPICHLOROHYDRIN	13.00
ETHANOL	10.70
ETHYLENE	10.2
ETHYLENE OXIDE	21.28
GAMMA BUTYROLACTONE	3.01
HYDRAZINE	2.60
HYDROGEN SULFIDE	6.25
ISOPROPANOL	8.66
JET A & JP8 FUEL	3.00
JET A1 FUEL	3.80
JP 5 FUEL	2.90
JP 8 FUEL	2.90
METHANOL (11.7 LAMP)	5.56
METHYL BENZYL ALCOHOL	7.12
METHYLENE CHLORIDE (11.7 LAMP)	2.04
METHYL ETHYL KETONE (MEK)	0.97
MONOMETHYLAMINE	2.07
N-METHYL PYRROLIDONE	1.81
PHENOL	8.90
PHENYL ETHYL ALCOHOL	9.04
2-PICOLINE	0.72

3-PICOLINE	0.92
STYRENE MONOMER	0.47
TERT BUTYL MEREAPTAN	0.78
TERTIARY BUTYL ALCOHOL	4.18
TURPENTINE - PURE GUM SPIRITS	0.50
TURPENTINE - CRUDE SULFATE	1.0
VINYL ACETATE	1.40
VINYLCYCLOHEXANE (VCH)	0.54
VINYL CHLORIDE	1.87

#### NOTE

- The response factor values in this table were obtained with the Passport PID II Monitor using dry bottled gases.
- These response factors apply only to 10.6 eV lamps. They are not valid for instruments using PID lamps at any other energy. Using these response factors with a lamp at any other energy will critically compromise the instrument's ability to detect organic compounds.

## Appendix C: Specifications

<b>Dimensions</b>	8.125" x 2.875" x 3.75"
<b>Weight</b>	With Type A battery: 2.5 lbs.
<b>Detector</b>	Photoionization
<b>Keypad</b>	Three tactile membrane switches
<b>Display</b>	Two line, 16-character dot matrix, liquid crystal for alphanumeric and analog concentration display.
<b>Serial output</b>	With optional Data Docking Module
<b>Sample inlet connection</b>	1/8" threaded fitting
<b>Sample inlet filters</b>	Water trap filter (probe)
<b>Sample flow rate</b>	350 cc/minute (average) with probe attached
<b>MSA Omega battery charger</b>	50/60 Hz 110 VAC standard, 50/60 Hz 220 VAC optional, 5 unit 110/220, 50/60 Hz optional, 8-24 VDC for vehicle use optional
<b>Materials in sample stream</b>	Teflon, Viton, PEEK, glass, silicone, nickel, stainless steel
<b>Operating humidity range</b>	0-95% Relative Humidity, (non-condensing)
<b>Operating temperature</b>	0 to 40 <sup>o</sup> C (32 - 104 <sup>o</sup> F)
<b>Typical operating time</b>	8 hours at 25 <sup>o</sup> C using Type A Ni-Cd Battery pack
<b>Minimum detectable quantity</b>	0.1 ppm isobutylene, 0.1 ppm benzene
<b>Detection range</b>	0.1-10,000 ppm isobutylene

<b>Response Time with probe</b>	6 seconds or less to 90% of final reading
<b>Repeatability</b>	± 1 %

## Appendix D: Options and Accessories

**Table 7-1. Battery Packs & Chargers**

Description	Part Number
Battery Pack, Ni-Cd C Cell Rechargeable, Type A	496990
Battery Pack, Ni-Cd, D Cell, Rechargeable, Type B	800527
Battery Pack, Alkaline C Cell	800526
110V 50/60 Hz Battery Charger	494716
220V 50/60 Hz Battery Charger	495965
110V/220V 50/60 Hz 5 Unit Battery Charger	801759

**Table 7-2. Calibration Equipment**

Description	Part Number
Regulator, 1.5 LPM	467896
Calibration Tubing (with T-valve, for use with 1.5 LPM regulator P.N. 467896)	809066
Calibration Tubing (for use with 0-2 LPM regulator, P.N. 697344)	814107
Quick-connect Calibration Adapter	636246
Zero Gas - Air	801050
Calibration Cylinder 100 ppm isobutylene in air	494450
Calibration regulator, demands	710288

**Table 7-3. Lamps & Accessories**

Description	Part Number
Lamp - 10.6 eV	815251
Lamp - 11.7 eV	655531
Lamp Cap	815256
Lamp Cleaning Kit	812155
Methanol Refill Kit	655650
Cleaning Kit Refill	655651

**Table 7-4. Filtering System Replacement Parts**

Description	Part Number
Water Trap (Teflon) Filter	636244
Pump Module	655771

**Table 7-5. Optional Equipment**

Description	Part Number
Belt Bracket	496366
Belt Loop & Swivel	803412
Earphone Assembly	633722
Wrist Strap	474407
Hand/Wrist Strap (fits boot and carrying case)	812834
Harness	474555
Passport PID Monitor Data Docking Module	804679
Passport PID II Monitor User's Manual	815253
Passport PID II Monitor Instruction Card	815254
Remote Alarm - Low (90 dB) Output	800992
Remote Alarm - High (105 dB) Output	800991
Shock Boot (fits Alkaline battery pack)	806748
Shock Boot (fits Ni-Cd battery packs, Type A & B)	806750
Soft Carrying Case with Harness	812833
Holster for using PID II with pistol grip	711006

**Table 7-6. Optional Sampling Equipment**

Description	Part Number
Fitting - barbed, 1/8" (2)	636246
Filter - replacement for probe	801582
Filter - water stop for probe	801582
Probe -1 ft., Peek™	800332
Probe - 1 ft., Teflon™	497600
Probe - 3 ft., Peek™	800333
Probe - 3 ft., Peek™ (holes 2" from tip)	803561
Probe - 3 ft., Peek™ (holes 2" from handle)	803962
Sampling Line - 10 ft., coiled, Teflon™	811187

## Appendix E: Ionization Potentials

Chemical Name	IP (eV)	Chemical Name	IP (eV)
Acetaldehyde	10.21	1-Butene	9.58
Acetamide	9.77	2-Butanone (MEK)	9.54
Acetic acid	10.69	cis-2-Butene	9.13
Acetic anhydride	10.00	trans-2-Butene	9.13
Acetone	9.69	3-Butene nitrile	10.39
Acetonitrile	12.20	n-Butyl acetate	10.01
Acetophenone	9.27	sec-Butyl acetate	9.91
Acetyl bromide	10.55	n-Butyl alcohol	10.04
Acetyl chloride	11.02	sec-Butyl alcohol	9.88
Acetylene	11.41	n-Butyl amine	8.71
Acrolein	10.10	s-Butyl amine	8.70
Acrylamide	9.50	t-Butyl amine	8.64
Acrylonitrile	10.91	n-Butyl benzene	8.69
Allyl alcohol	9.67	s-Butyl benzene	8.68
Allyl chloride	9.90	t-Butyl benzene	8.68
2-Amino pyridine	8.00	n-Butyl formate	10.50
Ammonia	10.20	Butyl mercaptan	9.15
Aniline	7.70	1-Butyne	10.18
Anisidine	7.44	n-Butyraldehyde	9.86
Anisole	8.22	n-Butyric acid	10.16
Arsine	9.89	n-Butyronitrile	11.67
Benzaldehyde	9.53	p-tert-Butyltoluene	8.28
Benzene	9.25	Camphor	8.76
Benzenethiol	8.33	Carbon dioxide	13.79
Benzonitrile	9.71	Carbon disulfide	10.07
Benzotrifluoride	9.68	Carbon monoxide	14.01
Biphenyl	8.27	Carbon tetrachloride	11.47
Boron oxide	13.50	Chlorine	11.48
Boron trifluoride	15.56	Chlorine dioxide	10.36
Bromine	10.54	Chlorine trifluoride	12.65
Bromobenzene	8.98	Chloroacetaldehyde	10.61
1-Bromobutane	10.13	α-Chloroacetophenone	9.44
2-Bromobutane	9.98	Chlorobenzene	9.07
1-Bromo-2-chloroethane	10.63	Chlorobromomethane	10.77
Bromochloromethane	10.77	1-Chlorobutane	10.67
1-Bromo-4-fluorobenzene	8.99	2-Chlorobutane	10.65
1-Bromo-2-methylpropane	10.09	1-Chloro-2-fluorobenzene	9.16
2-Bromo-2-methylpropane	9.89	1-Chloro-3-fluorobenzene	9.21
Bromoform	10.48	Chlorofluoromethane (Freon 22)	12.45
1-Bromopentane	10.10	Chloroform	11.37
1-Bromopropane	10.18	1-Chloro-2-methylpropane	10.66
2-Bromopropane	10.08	2-Chloro-2-methylpropane	10.61
1-Bromopropene	9.30	1-Chloropropane	10.82
3-Bromopropene	9.70	2-Chloropropane	10.78

Chemical Name	IP (eV)	Chemical Name	IP (eV)
---------------	---------	---------------	---------

2-Bromothiophene	8.63	3-Chloropropene	10.04
m-Bromotoluene	8.81	2-Chlorothiophene	8.68
o-Bromotoluene	8.79	m-Chlorotoluene	8.83
p-Bromotoluene	8.67	o-Chlorotoluene	8.83
1,3-Butadiene (butadiene)	9.07	p-Chlorotoluene	8.70
2,3-Butadiene	9.23	Chlorotrifluoromethane (Freon 13)	12.91
Butane	10.63	Chrysene	7.59
1-Butanethiol	9.14	Cresol	8.14
Crotonaldehyde	9.73	Dimethoxymethane (methylal)	10.00
Cumene (isopropyl benzene)	8.75	Dimethylphthalate	9.64
Cyanogen	13.80	2,2-Dimethyl propane	10.35
Cyclohexane	9.80	Dimethyl sulfide	8.69
Cyclohexanol	9.75	Dinitrobenzene	10.71
Cyclohexanone	9.14	Dioxane	9.19
Cyclohexene	8.95	p-Dioxane	9.13
Cyclo-octatetraene	7.99	Diphenyl	7.95
Cyclopentadiene	8.56	Dipropyl amine	7.84
Cyclopentane	10.53	Dipropyl sulfide	8.30
Cyclopentanone	9.26	Durene	8.03
Cyclopentene	9.01	Epichlorohydrin	10.20
Cyclopropane	10.06	Ethane	11.65
Decaborane	9.88	Ethanethiol (ethyl mercaptan)	9.29
Diazomethane	9.00	Ethanolamine	8.96
Diborane	12.00	Ethene	10.52
Dibromochloromethane	10.59	Ethyl acetate	10.11
Dibromodifluoromethane	11.07	Ethyl alcohol	10.48
1,1-Dibromoethane	10.19	Ethyl amine	8.86
1,2-Dibromoethene	9.45	Ethyl benzene	8.76
Dibromomethane	10.49	Ethyl bromide	10.29
1,3-Dibromopropane	10.07	Ethyl chloride (chloroethane)	10.98
Dibutylamine	7.69	Ethyl disulfide	8.27
m-Dichlorobenzene	9.12	Ethylene chlorohydrin	10.52
o-Dichlorobenzene	9.06	Ethylene diamine	8.60
p-Dichlorobenzene	8.95	Ethylene dibromide	10.37
Dichlorodifluoromethane (Freon 12)	12.31	Ethylene dichloride	11.05
1,1-Dichloroethane	11.12	Ethylenimine	9.20
1,2-Dichloroethane	11.12	Ethylene oxide	10.57
cis-Dichloroethene	9.65	Ethyl ether	9.51
trans-Dichloroethene	9.66	Ethyl formate	10.61
Dichlorofluoromethane	12.39	Ethyl iodide	9.33
Dichloromethane	11.35	Ethyl isothiocyanate	9.14
1,2-Dichloropropane	10.87	Ethyl mercaptan	9.29
1,3-Dichloropropane	10.85	Ethyl methyl sulfide	8.55
2,3-Dichloropropene	9.82	Ethyl nitrate	11.22

Chemical Name	IP (eV)	Chemical Name	IP (eV)
1,2-Dichloro-1,1,2,2-tetrafluoroethane (Freon 114)	12.20	Ethyl propionate	10.00
Diethoxymethane	9.70	Ethyl thiocyanate	9.89

N,N-Diethyl acetamide	8.60	Ethynylbenzene	8.82
Diethyl amine	8.01	Fluorine	15.70
Diethyl ether	9.53	Fluorobenzene	9.20
N,N-Diethyl formamide	8.89	o-Fluorophenol	8.66
Diethyl ketone	9.32	m-Fluorotoluene	8.92
Diethyl sulfide	8.43	o-Fluorotoluene	8.92
Diethyl sulfite	9.68	p-Fluorotoluene	8.79
Difluorodibromomethane	11.07	Formaldehyde	10.87
Dihydropyran	8.34	Formamide	10.25
Diiodomethane	9.34	Formic acid	11.05
Diisopropylamine	7.73	Freon 11 (trichlorofluoromethane)	11.77
N,N-Dimethyl acetamide	8.81	Freon 12 (dichlorodifluoromethane)	12.31
Dimethyl amine	8.24	Freon 13 (chlorotrifluoromethane)	12.91
Dimethylaniline	7.13	Freon 22 (chlorofluoromethane)	12.45
2,2-Dimethyl butane	10.06	Freon 112 (1,1,2,2-tetrachloro-1,2-difluoroethane)	11.30
2,3-Dimethyl butane	10.02	Freon 113 (1,1,2-trichloro-1,2,2-trifluoroethane)	11.78
3,3-Dimethyl butanone	9.17	Freon 114 (1,2-dichloro-1,1,2,2-tetrafluoroethane)	12.20
Dimethyl ether	10.00	2-Furaldehyde	9.21
Dimethylformamide	9.18	Furan	8.89
N,N-Dimethyl formamide	9.12	Furfural	9.21
1,1-Dimethylhydrazine	7.28	Heptane	10.08
1,1-Dimethoxyethane	9.65	2-Heptanone	9.33
Hexachloroethane	11.10	2-Methyl-1-butene	9.12
Hexane	10.18	3-Methyl-1-butene	9.51
2-Hexanone	9.35	3-Methyl-2-butene	8.67
1-Hexene	9.46	Methyl butyl ketone	9.34
Hydrazine	8.10	Methyl butyrate	10.07
Hydrogen	15.43	Methyl cellosolve	9.60
Hydrogen bromide	11.62	Methyl chloride	11.28
Hydrogen chloride	12.74	Methyl chloroform (1,1,1-trichloroethane)	11.00
Hydrogen cyanide	13.91	Methylcyclohexane	9.85
Hydrogen fluoride	15.77	4-Methylcyclohexene	8.91
Hydrogen iodide	10.38	Methyl disulfide	8.46
Hydrogen selenide	9.88	Methylene chloride	11.32
Hydrogen sulfide	10.46	Methyl ethyl ketone	9.53
Hydrogen telluride	9.14	Methyl formate	10.82
Hydroquinone	7.95	2-Methyl furan	8.39
Iodine	9.28	Methyl iodide	9.54
Iodobenzene	8.73	Methyl isobutyl ketone	9.30
Chemical Name	IP (eV)	Chemical Name	IP (eV)
1-Iodobutane	9.21	Methyl isobutyrate	9.98
2-Iodobutane	9.09	Methyl isocyanate	10.67
1-Iodo-2-methylpropane	9.18	Methyl isopropyl ketone	9.32
1-Iodopentane	9.19	Methyl isothiocyanate	9.25
1-Iodopropane	9.26	Methyl mercaptan	9.44
2-Iodopropane	9.17	Methyl methacrylate	9.70

m-Iodotoluene	8.61	1-Methyl naphthalene	7.96
o-Iodotoluene	8.62	2-Methyl naphthalene	7.96
p-Iodotoluene	8.50	2-Methylpentane	10.12
Isobutane	10.57	3-Methylpentane	10.08
Isobutyl acetate	9.97	2-Methyl propene	9.23
Isobutyl alcohol	10.12	Methyl propionate	10.15
Isobutyl amine	8.70	Methyl propyl ketone	9.39
Isobutyl formate	10.46	$\alpha$ -Methyl styrene	8.35
Isobutyraldehyde	9.74	Methyl thiocyanate	10.07
Isobutyric acid	10.02	Monomethyl aniline	7.32
Isopentane	10.32	Monomethyl hydrazine	7.67
Isophorone	9.07	Morpholine	8.20
Isoprene	8.85	Naphthalene	8.12
Isopropyl acetate	9.99	Nickel carbonyl	8.27
Isopropyl alcohol	10.16	Nitric oxide, (NO)	9.25
Isopropyl amine	8.72	Nitrobenzene	9.92
Isopropyl benzene	8.69	p-Nitrochloro benzene	9.96
Isopropyl ether	9.20	Nitroethane	10.88
Isovaleraldehyde	9.71	Nitrogen	15.58
Ketene	9.61	Nitrogen dioxide	9.78
2,3-Lutidine	8.85	Nitrogen trifluoride	12.97
2,4-Lutidine	8.85	Nitromethane	11.08
2,6-Lutidine	8.85	1-Nitropropane	10.88
Maleic anhydride	10.80	2-Nitropropane	10.71
Mesitylene	8.40	Nitrotoluene	9.45
Mesityl oxide	9.08	Octane	9.82
Methane	12.98	Oxygen	12.08
Methanethiol (methyl mercaptan)	9.44	Ozone	12.08
n-Methyl acetamide	8.90	Pentaborane	10.40
Methyl acetate	10.27	Pentane	10.35
Methyl acetylene	10.37	2,4-Pentanedione	8.87
Methyl acrylate	9.90	2-Pentanone	9.38
Methylal (dimethoxymethane)	10.00	1-Pentene	9.50
Methyl alcohol	10.85	Perchloroethylene	9.32
Methyl amine	8.97	Pheneloc	8.18
Methyl-n-amyl ketone	9.30	Phenol	8.50
Methyl bromide	10.54	Phenylene diamine	6.89
Phenyl ether (diphenyl oxide)	8.82	Sulfuryl fluoride	13.00
Phenyl hydrazine	7.64	o-Terphenyls	7.78

Chemical Name	IP (eV)	Chemical Name	IP (eV)
Phenyl isocyanate	8.77	1,1,2,2-Tetrachloro-1,2-difluoroethane (Freon 112)	11.30
Phenyl isothiocyanate	8.52	Tetrachloroethane	11.62
Phosgene	11.77	Tetrachloroethene	9.32
Phosphine	9.87	Tetrachloromethane	11.47
Phosphorus trichloride	9.91	Tetrahydrofuran	9.54
Phthalic anhydride	10.00	Tetrahydropyran	9.25
2-Picoline	9.02	Thiolacetic acid	10.00
3-Picoline	9.02	Thiophene	8.86
4-Picoline	9.04	Toluene	8.82
Propane	11.07	o-Toluidine	7.44
1-Propanethiol	9.20	Tribromoethene	9.27
Propargyl alcohol	10.51	Tribromofluoromethane	10.67
Propiolactone	9.70	Tribromomethane	10.51
Propionaldehyde	9.98	1,1,1-Trichloroethane	11.00
Propionic acid	10.24	Trichloroethene	9.45
Propionitrile	11.84	Trichloroethylene	9.47
Propyl acetate	10.04	Trichlorofluoromethane (Freon 11)	11.77
Propyl alcohol	10.20	Trichloromethane	11.42
Propyl amine	8.78	1,1,2-Trichloro-1,2,2-trifluoroethane (Freon 113)	11.78
Propyl benzene	8.72	Triethylamine	7.50
Propylene	9.73	Trifluoromonomethane	11.40
Propylene dichloride	10.87	Trimethyl amine	7.82
Propylene imine	9.00	2,2,4-Trimethyl pentane	9.86
Propylene oxide	10.22	Tripropyl amine	7.23
Propyl ether	9.27	Valeraldehyde	9.82
Propyl formate	10.54	Valeric acid	10.12
n-Propyl nitrate	11.07	Vinyl acetate	9.19
Propyne	10.36	Vinyl bromide	9.80
Pyridine	9.32	Vinyl chloride	10.00
Pyrrole	8.20	Vinyl methyl ether	8.93
Quinone	10.04	o-Vinyl toluene	8.20
Stibine	9.51	Water	12.59
Styrene	8.47	m-Xylene	8.56
Sulfur dioxide	12.30	o-Xylene	8.56
Sulfur hexafluoride	15.33	p-Xylene	8.45
Sulfur monochloride	9.66	2,4-Xylidine	7.65

**MSA and Passport are trademarks of Mine Safety Appliances Company.**