

P/N 1709-4756
REV 0 PRINTED 0601-5,000
Specifications Subject to Change

Single Gas Monitor

T82



**GUARANTEED.
FOR LIFE.**

1001 Oakdale Road, Oakdale, PA 15071-1500
(412) 788-4353 Toll Free 1-800-DETECTS
FAX 412-788-8353

INDUSTRIAL SCIENTIFIC
CORPORATION

Instruction
Manual

OUR MISSION

*Design - Manufacture - Sell:
Highest quality products
for the preservation of
life and property.*

*Provide:
Best customer service
available.*

Dear Valued Customer:

Thank you for buying and using Industrial Scientific's Model T82 Single Gas Monitor.

Your T82 can be relied upon for dependable service, day after day. It has been designed, manufactured, tested and proven under the most scrutinizing conditions possible. With the minimal care and maintenance described in this Instruction Manual, it will provide you with years of reliable monitoring.

I am most concerned that you be pleased with the performance of your T82 in the months and years ahead. I urge you to call us with any questions or comments you may have. Often times a phone call and a question can save you hours of frustration. Please never hesitate to contact me at 1-800-DETECTS (338-3287).

All of us at Industrial Scientific appreciate the opportunity to serve you.

Yours very truly,

A handwritten signature in black ink, appearing to read "Kent D. McElhattan". The signature is stylized and cursive.

Kent D. McElhattan
President & CEO
Industrial Scientific Corporation

TABLE OF CONTENTS

1.	WARNINGS & CAUTIONARY STATEMENTS	3
2.	UNPACKING THE INSTRUMENT	4
3.	T82 FEATURES	4
4.	INSTRUMENT OPERATION	7
4.1	Turning the T82 On and Off	7
4.2	T82 Operating Modes	8
4.2.1	Reading	8
4.2.2	Display Backlight	8
4.2.3	Sensor Identification	8
4.2.4	Zero	8
4.2.5	Peak	9
4.2.6	STEL	9
4.2.7	TWA	9
4.2.8	Battery Status	9
4.2.9	Datalog Usage	9
4.2.10	Datalog Start New Session	10
4.3	T82 Alarm Indicators	10
4.4	T82 Error Code Indication	11
5.	CALIBRATING THE T82	12
6.	VIEWING AND CHANGING INSTRUMENT SETTINGS, CLEARING DATA	13
7.	MAINTENANCE	15
7.1	Cleaning	15
7.2	Opening the Instrument	15
7.3	Changing the Battery	15
8.	INSTALLING OR CHANGING SMART SENSOR MODULES	16
9.	REPLACEMENT PARTS	18
10.	SPECIFICATIONS	19
11.	T82 OPTIONS & ORDERING INFORMATION	22
12.	WARRANTY	26

1. WARNINGS & CAUTIONARY STATEMENTS

Failure to observe certain procedures or conditions may impair the performance of the instrument. For maximum safety and performance while using the instrument, please read and understand the procedures and conditions outlined below.

- ▲ The T82 is not intended for use in oxygen enriched atmospheres.
- ▲ Sensor aperture area and water barrier must be kept clean. Obstruction of the sensor aperture area and/or contamination of the sensor aperture water barrier may cause readings to be lower than actual gas concentrations.
- ▲ Sudden changes in atmospheric pressure may cause temporary fluctuations in oxygen readings.
- ▲ Instrument is tested for intrinsic safety in explosive gas/air (21% oxygen) mixtures only.
- ▲ Instrument is not approved for operation with batteries other than those listed on the battery holder label.
- ▲ The model T82 (P/N 1810-2318) complies with the European EMC directives 89-336-EEC, 92-31-EEC and 93-68-EEC.
- ▲ Substitution of components may impair intrinsic safety.

2. UNPACKING THE INSTRUMENT

The shipping box should contain the following items. Account for each item before discarding containers.

QUANTITY	PART NUMBER	DESCRIPTION
1	1810-4133	T82 Single Gas Monitor
1	1709-4756	T82 Instruction Manual
1	1700-7147	Maintenance Tool

After unpacking, if any item listed is missing, contact either your local distributor of Industrial Scientific products, or call Industrial Scientific Corporation at 1-800-DETECTS (338-3287) in the United States and Canada, or (412) 788-4353.

3. T82 FEATURES

- The Industrial Scientific T82 Single Gas Monitor may be configured to continuously monitor any one of the following gases:
 - Oxygen (O₂)
 - Carbon Monoxide (CO)
 - Hydrogen Sulfide (H₂S)
 - Sulfur Dioxide (SO₂)
 - Nitrogen Dioxide (NO₂)
 - Chlorine Dioxide (ClO₂)
 - Nitric Oxide (NO)
 - Chlorine (Cl₂)
 - Hydrogen Chloride (HCl)
 - Hydrogen Cyanide (HCN)
 - Phosphine (PH₃)
 - Hydrogen (H₂)
 - Ammonia (NH₃)
 - Ozone (O₃)

- The T82 automatically recognizes and displays sensor configuration when switched on.
- Automatic calibration requires no user settings or adjustments unless changes to default settings are desired.
- One-button microprocessor controlled operation.
- High intensity illuminated display for viewing in low light conditions. Backlight automatically turns off after a predetermined time to conserve battery life.
- In excess of 2300 hours of continuous operating time using a standard 9-volt alkaline battery or 4000 hours with the optional long-life lithium 9-volt battery.
- Plug-in *Smart* Sensor modules that can be changed or replaced without special tools or soldering equipment. Modules of the same or different types may be installed as needed. Specific calibration and alarm settings are retained with each module.
- High output 90dB audible and ultra-bright visual alarm indicators.
- Optional field-installable vibrating alarm.
- Dual level alarms for both oxygen and toxic gases.
- User selectable confidence beep.
- PEAK, STEL and TWA enhanced readings modes.
- User selectable calibration gas concentration.
- Instant on/delayed turn-off of press-and-hold power switch to prevent accidental turn off.
- Easily accessible internal setup switches for tamper-resistant operation.

- The T82 is classified as intrinsically safe by the following agencies:
 - Underwriters Laboratories (UL)
 - Canadian Standard Association (CSA)
 - CENELEC (Europe)
 - Mine Safety and Health Administration (MSHA)
 - Workcover (Australia)
- 38.4k baud serial interface for communications to personal computer of DS1000 Docking Station.
- Data storage capability (datalog) with programmable recording interval from 1 to 300 seconds (5 minutes). Datalogging capacity of a minimum of 90 hours when recording at 1 reading per minute. Exact logging capacity is dependent of the number of logging sessions (datalogging units only).
- Programmable TWA from 1 to 40 hours.
- Real-time clock/calendar.

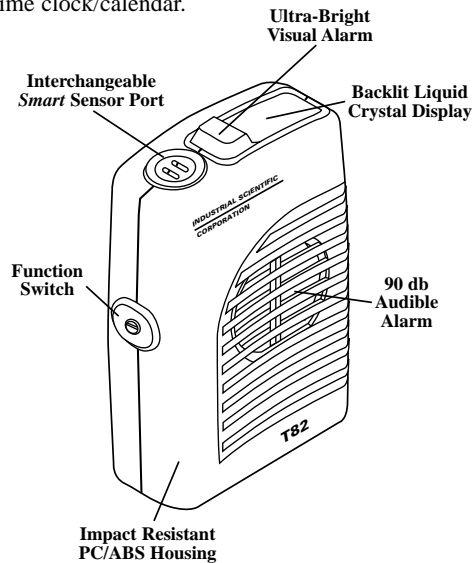

4. INSTRUMENT OPERATION

4.1 TURNING THE T82 ON AND OFF

To turn on the T82, press and hold the function switch. The display will show ON and the instrument will beep once. After 1 second, all display segments and annunciators will light at which time the function switch may be released.

NOTE: *If the function switch is released prior to completion of the 1 second delay, the instrument start-up will be aborted and the T82 will turn off.*

DISPLAY TEST: All display segments and annunciators are activated to verify operation.

SENSOR CONFIGURATION: The type of sensor currently installed in the instrument is displayed.

BATTERY STATUS: The current battery condition is displayed as a series of bars. Three rows of bars indicates a good battery condition. Two rows of bars indicates a marginal battery condition (approximately 70 hours remain). If a single row of bars is displayed, the battery should be replaced immediately.

SOFTWARE VERSION: The display will indicate the version of operating software installed in the instrument.

ALARM TEST: Just prior to the start of normal operation, the instrument will briefly activate the visual and vibrating alarms (if installed) to verify proper alarm function.

COUNT-DOWN TIMER: The display will indicate the number of seconds remaining until the instrument begins normal operation.

To turn the T82 off after use, press and hold the function switch. The display will show OFF and the instrument will beep once per second. After five seconds the display will blank and instrument operation will cease. If the function switch is released during the five second delay, the instrument will return to the normal operating mode.

4.2 T82 OPERATING MODES

The T82 offers different operating modes for accessing various instrument features. To scroll through and view the T82 operating modes, press and release the function switch. The operating modes are accessed in the following sequence.

4.2.1 READING

This is the normal operation mode. The current gas reading is displayed numerically. If the current reading exceeds the specified maximum (see specifications of page 21), the LCD will show a 1 in the left most digit will all other digits blank to indicate the over-range condition.

4.2.2 DISPLAY BACKLIGHT

The T82 display will illuminate for viewing in low light conditions when the function switch is pressed or when an alarm condition occurs. Following the release of the function switch, the backlight will turn off in 6 seconds.

4.2.3 SENSOR IDENTIFICATION

The T82 will display the type of sensor currently installed in the instrument.

4.2.4 ZERO

This mode allows the user to zero the instrument in clean air. The display will indicate -0- when in the zero mode. To zero the toxic gas sensor (or reset the oxygen sensor), double click the function switch. The instrument will beep, the display will be reset to zero (20.9% oxygen) and the instrument will return to the normal operational reading mode. If the offset is greater than the sensor specified maximum, the instrument will not beep, the display will remain at its previous value and the instrument will return to normal operational reading mode.

4.2.5 PEAK

This mode will display the highest concentration of toxic gas or the lowest concentration of oxygen detected since the peak reading was last cleared. To reset the PEAK reading, double click the function switch while on the PEAK screen. The PEAK reading will be reset to zero for toxic gases (20.9% oxygen) and the instrument will return to the normal operational reading mode.

NOTE: *The TWA and STEL modes are not accessible when the oxygen sensor is installed.*

4.2.6 STEL

This mode will display the current 15 minute Short Term Exposure Limit concentration of toxic gas. The STEL reading is reset each time the instrument is turned off.

4.2.7 TWA

This mode will display the current Time Weighted Average (based on programmable TWA time base, 1-40 hours) concentration of toxic gas accumulated since the T82 began a new datalog session. The TWA reading is reset each time a new datalog session is initiated.

4.2.8 BATTERY STATUS

This mode allows the user to view the current battery status. Refer to Section 4.1 for a description of the display status indicators.

NOTE: *If the function switch is not depressed after three seconds from any operating mode, the instrument display will return to the normal operating mode.*

4.2.9 DATALOG USAGE (Datalogging Units Only)

This mode allows the user to view the percentage (1-100%) displayed as L01-L99 or FUL for 100%) of datalogging memory (EEPROM) used. The size of the datalogging memory (EEPROM) is 16,384 bytes (3 bytes required per stored reading).

When the datalogging memory (EEPROM) is full, a percentage will not be displayed, but FUL will appear on the display to indicate this. Once the datalogging memory is full, clearing of the memory must be performed in order to log any additional data.

NOTE: *Clearing of the datalogging memory (EEPROM) can be performed by the user as described in section 6 or by using the T82 datalogging software (part of 1810-4281 T82 Datalogging Kit).*



WARNING: *T82 Datalogging Kit (1810-4281) not suitable for use in hazardous locations.*

4.2.10 DATALOG START NEW SESSION (Datalogging Units Only)

This mode allows the user to end the current datalogging session and begin a new one. The current session number will be displayed as H01-H99. To start a new session, double click the function switch. The instrument will beep and will return to the normal operational reading mode. If the datalog memory is full, the instrument will not beep and will return to the previous mode (datalog usage). The datalog usage menu will appear as FUL in this case.

NOTE: *If datalogging memory (EEPROM) is full, performing the above procedure will not begin a new session. The datalogging memory (EEPROM) must be cleared as described in section 6.*

4.3 T82 ALARM INDICATORS

The T82 is equipped with several alarm indicators. These include a high output audio speaker, ultra-bright alarm LED, and an optional internal vibrating alarm.

The intelligent power management system within the T82 operates each of the alarm indicators in a sequential fashion during each second, such that no two alarms are on at the same time. This maximizes energy usage from the battery.

For low alarm conditions of toxic gases, the speaker produces a fixed frequency pulse once per second along with the flashing alarm led and backlight. If the vibrating alarm option is installed, it also pulses once per second.

For high alarm conditions of toxic gases and either low or high oxygen alarms, the speaker produces two alternating tones each second along with the flashing alarm LED and backlight. If the vibrating alarm option is installed, it also pulses once per second.

While in the normal operating mode, the T82 will respond to and display all appropriate alarm conditions. As each alarm point is activated, its associated display annunciator will light to indicate which alarms are currently active. However, only the current gas reading is displayed unless the other viewing modes are selected.

If a low battery condition is encountered while in the normal operating mode, the BAT display annunciator will light and the instrument will emit a short beep each second. Approximately 70 hours of non-alarming instrument operation will remain once the BAT annunciator is displayed.

4.4 T82 ERROR CODE INDICATION

The T82 has internal diagnostics capable of detecting and displaying the following error codes:

- Er1 > error code 1 > sensor module EEPROM failure
- Er4 > error code 4 > error reading T82 sensor module identification code
- Er6 > error code 6 > 1V reference out of range
- Er 7 > error code 7 > 4V instrument voltage out of range
- Er8 > error code 8 > 32.768khz crystal failure
- Er9 > error code 9 > watchdog timer time-out

When one of the above errors is encountered, the instrument will display the error code and beep approximately 8 times in a second, continuously, until the user presses the Function switch. After the switch press, the instrument will clear the display and power down (off). The user can turn power back on to determine if the error is persistent or occurred just the one time.

5. CALIBRATING THE T82

Gas detection instruments are potential life-saving devices. Recognizing this fact, Industrial Scientific Corporation recommends that a functional (“bump”) test be performed on every instrument prior to each use. A functional test is defined as a brief exposure of the monitor to a concentration of gas(es) greater than the alarm setpoint of the instrument for the purpose of verifying sensor and alarm operation and is not intended to be a measure of the accuracy of the instrument.

Industrial Scientific further recommends that a full instrument calibration be performed using a certified concentration(s) of calibration gas(es) monthly to ensure maximum accuracy.

If an instrument fails to operate properly following any functional “bump” test, a full instrument calibration should be performed prior to use.

If the concentration of calibration gas is the same as the CAL GAS setting (as indicated in the Setup modes), simply perform the following steps to calibrate the T82:

- Turn on T82 and run in normal reading mode.
- For toxic gases, turn on calibration gas at 1 LPM (0.5 LPM for H₂S, CO, SO₂ and O₂. Clean ambient air may be used for oxygen).

- Insert T82 into calibration cup/adapter.
- Press and hold the Function switch until the instrument beeps and shows “CAL” on the display followed by the uncalibrated sensor reading.
- There will be a maximum calibration time of 30 seconds for oxygen and 2-5 minutes time-out for the various toxic gases. The instrument has an auto-calibrate routine that will complete the calibration before this time (minimum calibration time possible is 25% of the maximum calibration time). At the end of this time, the displayed reading should be greater than 50% of the applied gas value. If the displayed reading is less than 50% of the gas value, the T82 will fail calibration and the sensor should be replaced.
- The T82 signals end of calibration with a short beep once per second and indicates the calibration status by displaying a “P” for Pass or “F” for Fail.
- Remove the T82 from the calibration cup/adapter.
- Turn off the gas regulator valve.

6. VIEWING AND CHANGING INSTRUMENT SETTINGS, CLEARING DATA

All T82 alarm settings may be viewed and adjusted by the user along with the calibration gas value and the status of the instrument confidence beep. However the setting may only be accessed immediately after the instrument has been turned ON.

To view T82 settings, press the Function switch while the five second warm-up timer is displayed during the startup sequence. The instrument will enter the settings mode.

T82 settings may be viewed in the following order.

LOW ALARM
HIGH ALARM
TWA ALARM
STEL ALARM
CAL GAS
Confidence BEEP
Clear Datalog (Datalogging Units Only)

The current value of each setting may be viewed by pressing the Function switch in succession to scroll through each setting mode. Each of the T82 settings may be changed by pressing the + or - keys located under the instrument case top, while the current setting is being viewed. For datalogging units, an additional setting displaying LCL will allow the user to clear the entire datalog memory. To clear the entire datalog memory, double click the function switch. The instrument will beep, clear the entire datalog memory, and will return to the normal operational reading mode. To remove the case top and access the hidden keys, refer to Section 7.2, Opening the Instrument for instructions.

The settings menu may be exited by scrolling through each of the six selections or by allowing the T82 to remain idle in the settings mode for 30 seconds. After exiting the settings mode, the T82 will immediately begin normal operation.

If adjustments to instruments settings are completed, the instrument should be turned off, and the case reassembled before resuming normal operation. When the instrument is turned off, all instrument settings will be stored in memory and recalled when the instrument is turned on.

7. MAINTENANCE

7.1 CLEANING

Wipe the outside of the instrument with a soft, clean cloth. Never use solvents.

7.2 OPENING THE INSTRUMENT

- Be sure the instrument is turned off as in section 4.1.
- Loosen the 4 screws in the case bottom using the service tool provided. Note that these are captive screws and will not become detached from the case bottom.

7.3 CHANGING THE BATTERY



The T82 is shipped from the factory with the specified type of battery installed and ready for immediate operation. Because the T82 consumes an insignificant amount of battery energy while turned off, the total battery life will not be affected during shipment and storage.

To install a new battery or replace the existing one, perform the following procedure:

- Open the instrument as shown in Section 7.2 as described.
- Using the finger notch in the end of the battery compartment, remove the existing battery.
- Observing proper polarity as indicated on the battery compartment, install the new battery by first inserting the terminal end of the battery. Then, press the battery against the spring contacts and insert the back end of the battery into the battery compartment.



WARNING: *Replace the battery only in a non-hazardous location.*

-  **WARNING:** *Lithium and Alkaline batteries may leak or explode if mistreated. Do not attempt to recharge, disassemble, or dispose of in fire.*
-  **WARNING:** *Be certain that the instrument case is reassembled as supplied from the factory to avoid loss of ingress protection or intrinsic safety.*
-  **WARNING:** *Use only approved battery types as indicated on the battery compartment label. Failure to use an approved battery will adversely affect intrinsic safety.*

8. INSTALLING OR CHANGING SMART SENSOR MODULES

To install a new sensor module:

- Turn off the instrument and open the instrument as in Section 7.2. Carefully remove the sensor module by pulling it up away from the bottom PC board.
- Align the new sensor module with the guide slots in the case bottom and press the board firmly in place. Ensure that the connector on the sensor module is fully engaged with the connector in the main P.C. board.
- If it is desired to verify or change any instrument settings, it can be done now while the case is open. Turn off the instrument and reassemble reversing the procedure described in Section 7.2.

The new module should not require calibration before use. However, for maximum assurance of proper operation, the instrument should be exposed to the appropriate gas before use to confirm sensor response.

The *smart* sensor module contains all related setup parameters including:

- Low alarm setpoint
- High alarm setpoint
- STEL alarm setpoint
- TWA alarm setpoint
- Calibration factors
- Temperature compensation values

NOTE: *Upon installation of a bias sensor module (NH₃, NO or HCl), a stabilization time period is required for the sensor. This time will vary based on the sensor and sensor type, and can range from one hour to two days.*

9. REPLACEMENT PARTS

Item numbers refer to Figure 2, Exploded View.

ITEM	PART NUMBER	DESCRIPTION (QTY)
1	1708-4930	Case Top (1)
2	1708-4948	Case Bottom (1)
3	1705-8975	Sensor Seal (1)
4	1705-8983	Function Switch Seal (1)
5	1705-8991	PC Board Cover (1)
6	1705-9007	Display Window (1)
7	1706-0328	Liquid Crystal Display (1)
8	1705-8777	Sensor Cover (1)
9	1706-2787	Sensor Screen
10	1705-8918	Speaker Water Barrier (1)
11	1705-8736	2-56 x .75 Screw (4)
12	1705-7118	Speaker (1)

For your convenience and protection, record the serial number of your T82 Single Gas Monitor in the space provided.

Serial No. _____

10. SPECIFICATIONS

CASE:	RFI resistant ABS housing
DIMENSIONS:	4.13" x 2.65" x 1.20" (102mm x 68mm x 34mm)
WEIGHT:	7 ounces (198g)
POWER SOURCE:	Alkaline 9-volt battery (standard) Lithium 9-volt battery (optional)
BATTERY LIFE:	2300 hrs minimum with alkaline 9-volt battery 4000 hrs minimum with lithium 9-volt battery
READOUT:	3.5 digit numeric LCD with annunciators
HUMIDITY RANGE:	20% to 99% RH noncondensing
OPERATING TEMPERATURE:	O ₃ -10C to 40C (14F to 104F)
	Cl ₂ , ClO ₂ , PH ₃ , HCl -20C to 40C (-4F to 104F)
	CO, NO, NO ₂ , O ₂ , SO ₂ , H ₂ -20C to 50C (-4F to 122F)
	NH ₃ -25C to 30C (-13F to 86F)
	HCN -40C to 40C (-40F to 104F)
	H ₂ S -40C to 50C (-40F to 122F)

DEFAULT ALARM SETTINGS

	Low	High	TWA	STEL
O ₂	19.5	23.5	N/A	N/A
CO	35	70	35	400
H ₂ S	10	20	10	15
SO ₂	2.0	4.0	2.0	5.0
NO ₂	3.0	6.0	3.0	5.0
ClO ₂	0.3	1.0	0.1	0.3
NO	25	50	25	25
Cl ₂	0.5	1.0	0.5	1.0
HCl	2.5	5.0	2.5	5.0
HCN	5.0	10.0	4.0	4.0
PH ₃	0.3	0.6	0.3	1.0
H ₂	50	100	1999	1999
NH ₃	25	50	25	35
O ₃	0.2	0.4	0.2	0.4

MEASURING RANGES

O ₂	0-30.0% by volume in 0.1% increments
CO	0-1500 ppm in 1 ppm increments
H ₂ S	0-500 ppm in 1 ppm increments
SO ₂	0.2-150.0 ppm in 0.1 ppm increments
NO ₂	0.2-150.0 ppm in 0.1 ppm increments
ClO ₂	0.2-10.0 ppm in 0.1 ppm increments
NO	0-1000 ppm in 1 ppm increments
Cl ₂	0.2-150.0 ppm in 0.1 ppm increments
HCl	0-30.0 ppm in 0.1 ppm increments
HCN	0.2-150.0 ppm in 0.1 ppm increments
PH ₃	0.-10.0 ppm in 0.1 ppm increments
H ₂	0-1999 ppm in 1 ppm increments
NH ₃	0-200 ppm in 1 ppm increments
O ₃	0-10.0 ppm in 0.1 ppm increments

11. T82 OPTIONS & ORDERING INFORMATION

1810-4281	Datalink, T82	1810-1758	Cylinder, Calibration gas, 10 ppm Chlorine (58 liters)
1709-3766	Oxygen (2 year) sensor module	1810-2154	Cylinder, Calibration gas, 10 ppm Hydrogen Chloride (58 liters)
1706-0492	Carbon Monoxide sensor module	1810-1477	Cylinder, Calibration gas, 25 ppm Nitrogen Dioxide (58 liters)
1706-0526	Hydrogen Sulfide sensor module	1810-2153	Cylinder, Calibration gas, 25 ppm Nitric Oxide (58 liters)
1706-0534	Sulfur Dioxide sensor module	1810-2152	Cylinder, Calibration gas, 10 ppm HCN (58 liters)
1706-0542	Nitrogen Dioxide sensor module	1810-4059	Cylinder, Calibration gas, 1.0 ppm Phosphine (58 liters)
1707-2513	Chlorine Dioxide sensor module	1810-3945	Cylinder, Calibration gas, 100 ppm Hydrogen (58 liters)
1708-9921	Nitric Oxide sensor module	1810-2151	Cylinder, Calibration gas, 25 ppm Ammonia (58 liters)
1706-0559	Chlorine sensor module	1810-0933	Flow regulator for 34 liter cylinders (0.2 to 4 LPM)
1709-4749	Hydrogen Chloride sensor module	1810-1766	Flow regulator for 58 liter cylinders (1 LPM)
1707-2521	Hydrogen Cyanide sensor module	6810-0213	Flow regulator for 58 liter cylinders (0.5 LPM)
1707-8833	Phosphine sensor module	1810-2155	Flow regulator for 58 liter ammonia cylinders (1 LPM)
1708-9947	Hydrogen sensor module	1705-0605	Teflon lined tygon tubing
1708-9939	Ammonia sensor module		
1709-4731	Ozone sensor module		
1706-1508	Suspender clip		
1706-1516	Belt clip		
1705-9189	Calibration cup/adapter		
1705-8900	Sensor water barrier		
1705-8918	Speaker water barrier		
1703-3648	9-volt alkaline battery		
1706-1755	9-volt lithium battery		
1810-0701	Cylinder, Calibration gas, 100 ppm Carbon Monoxide (34 liters)		
1810-0859	Cylinder, Calibration gas, 25 ppm Hydrogen Sulfide (58 liters)		
1810-1220	Cylinder, Calibration gas, 10 ppm Sulfur Dioxide (58 liters)		

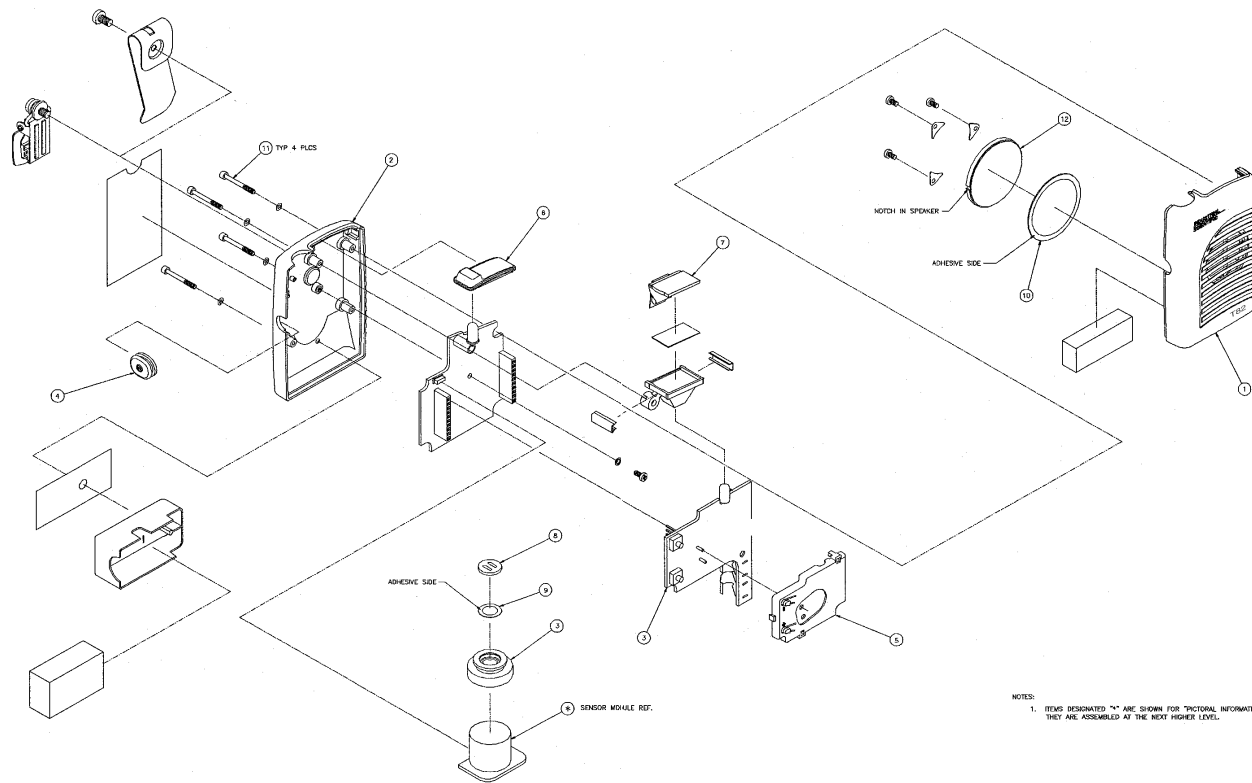

NOTES:
 1. ITEMS DESIGNATED "1" ARE SHOWN FOR "PICTORIAL INFORMATION" ONLY. THEY ARE ASSEMBLED AT THE NEXT HIGHER LEVEL.

Figure 2
Exploded View

12. WARRANTY

Industrial Scientific portable gas monitoring instruments are warranted to be free from defects in material and workmanship for as long as the instrument is in service.

The above warranty does not include sensors, battery packs, internal pumps or filters, all of which are warranted to be free from defects in material and workmanship for eighteen months from the date of shipment, or one year from the date of first use, whichever occurs first, except where otherwise stated in writing in Industrial Scientific literature accompanying the product.

All other Industrial Scientific products are warranted to be free from defects in material and workmanship for a period of eighteen (18) months from the date of shipment, or one (1) year from the date of first use, whichever occurs first, except where otherwise stated in writing in Industrial Scientific literature accompanying the product.

LIMITATION OF LIABILITY

INDUSTRIAL SCIENTIFIC MAKES NO OTHER WARRANTIES, EITHER EXPRESSED OR IMPLIED, INCLUDING BUT NOT LIMITED TO THE WARRANTIES OF MERCHANTABILITY OR FITNESS FOR PARTICULAR PURPOSE. SHOULD THE PRODUCT FAIL TO CONFORM TO THE ABOVE WARRANTY, BUYER'S ONLY REMEDY AND INDUSTRIAL SCIENTIFIC'S ONLY OBLIGATION SHALL BE, AT INDUSTRIAL SCIENTIFIC'S SOLE OPTION, REPLACEMENT OR REPAIR OF SUCH NON-CONFORMING GOODS OR REFUND OF THE ORIGINAL PURCHASE PRICE OF THE NON-CONFORMING GOODS.

IN NO EVENT WILL INDUSTRIAL SCIENTIFIC BE LIABLE FOR ANY OTHER SPECIAL, INCIDENTAL OR CONSEQUENTIAL DAMAGES, INCLUDING LOSS OF PROFIT OR LOSS OF USE, ARISING OUT OF THE SALE, MANUFACTURE OR USE OF ANY PRODUCTS SOLD HEREUNDER WHETHER SUCH CLAIM IS PLEADED IN CONTRACT OR IN TORT, INCLUDING STRICT LIABILITY IN TORT.

It shall be an express condition to Industrial Scientific's warranty that all products be carefully inspected for damage by Buyer upon receipt, be properly calibrated for Buyer's particular use, and be used, repaired, and maintained in strict accordance with the instructions set forth in Industrial Scientific's product literature. Repair or maintenance by non-qualified personnel will invalidate the warranty, as will the use of non-approved consumables or spare parts. As with any other sophisticated product, it is essential and a condition of Industrial Scientific's warranty that all personnel using the products be fully acquainted with their use, capabilities and limitations as set forth in the applicable product literature.

Buyer acknowledges that it alone has determined the intended purpose and suitability of the goods purchased. It is expressly agreed by the parties that any technical or other advice given by Industrial Scientific with respect to the use of the goods or services is given without charge and at Buyer's risk; therefore, Industrial Scientific assumes no obligations or liability for the advice given or results obtained.