

Multi-Gas Monitor

LTX311/312



Instruction
Manual

OUR MISSION

*Design - Manufacture - Sell:
Highest quality products
for the preservation of
life and property.*

*Provide:
Best customer service
available.*

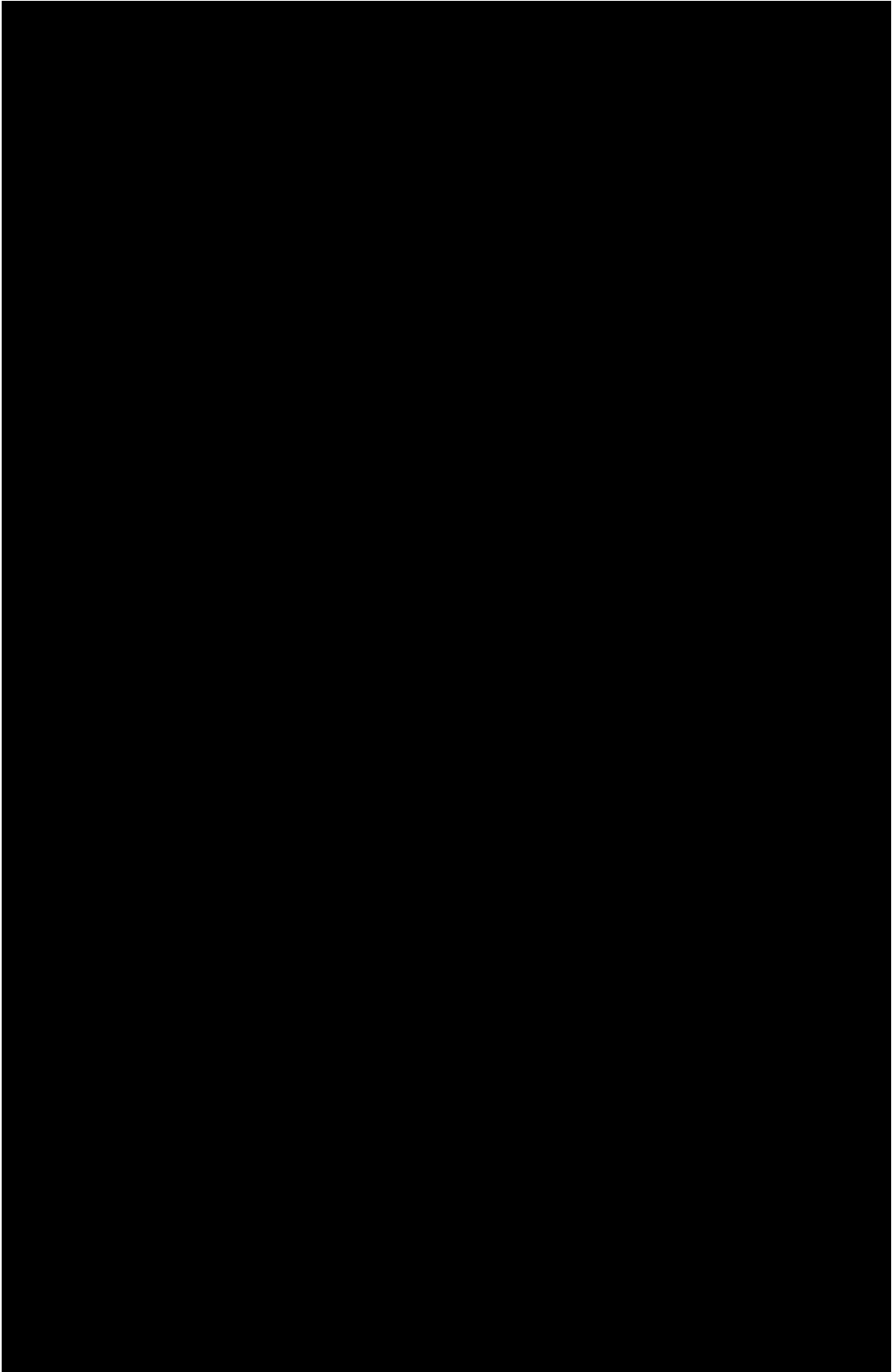

LTX311/312

Multi-Gas
Monitor

TABLE OF CONTENTS

<i>1.</i>	WARNINGS AND CAUTIONARY STATEMENTS	3
<i>2.</i>	UNPACKING THE INSTRUMENT	4
<i>3.</i>	LTX311/312 OVERVIEW AND FEATURES	4
<i>4.</i>	BASIC OPERATION	8
	4.1 Turning the LTX311/312 On	8
	4.2 Turning the LTX311/312 Off	8
	4.3 Startup Routine	8
<i>5.</i>	BASIC OPERATION MODES	9
	5.1 Reading Mode	9
	5.2 PPM Hydrogen Mode (LTX312 only)	9
	5.3 Zero Mode	10
	5.4 Peak Mode	10
	5.5 Peak Clear Mode	10
<i>6.</i>	ALARMS AND OTHER INDICATORS	10
	6.1 Fault Indication	11
	6.2 Gas Level Alarms	11
	6.3 Low-Level Alarm	12
	6.4 High-Level Alarm	12
	6.5 Combustible Gas Over-Range	12
	6.6 Battery Alarms	13
	6.4.1 Battery Indicator	13
	6.4.2 Low Battery Warning	13
	6.4.3 Battery Failure	13
<i>7.</i>	CHANGING INSTRUMENT SETTINGS	13
	7.1 Setspan	14
	7.2 Alarms	15
	7.3 Display	16
	7.4 Latch	17
	7.5 Battery	17
	7.6 Code	18
<i>8.</i>	SENSOR ZEROING AND CALIBRATION	18
	8.1 Zeroing	19
	8.2 Calibrating the Toxic/Combustible Gas Sensors	20
<i>9.</i>	REMOTE SAMPLING	22
<i>10.</i>	BASIC MAINTENANCE AND REPAIR	23
	10.1 Cleaning	23
	10.2 Charging the Battery Pack	23
	10.3 Replacing the Battery Pack	24
	10.4 Replacing the Gas Sensors	24
	10.5 Replacing the Water Barriers	26
<i>11.</i>	REPLACEMENT PARTS	27
<i>12.</i>	SPECIFICATIONS	30
<i>14.</i>	DEFAULT ALARM SETTINGS	31
<i>14.</i>	OPTIONAL PARTS AND ACCESSORIES	32
<i>15.</i>	WARRANTY	33

1. WARNINGS AND CAUTIONARY STATEMENTS

Failure to observe certain procedures or conditions may lead to personal injury and/or impair the performance of the instrument. For maximum safety and performance, please read and understand the warnings and cautions listed below.

- ▲ Sudden changes in atmospheric pressure may cause temporary fluctuations in the oxygen reading.
- ▲ Recharge the Ni-Cad battery pack in a nonhazardous location only.
- ▲ Do not recharge alkaline batteries in or out of the unit.
- ▲ Oxygen and toxic gas alarms are set according to different criteria and their alarms indicate different conditions (see Gas Level Alarms).
- ▲ Use only Teflon-lined tubing when calibrating the unit with a gas cylinder, as many of the calibration gases are highly reactive.
- ▲ Unit is tested for intrinsic safety only in explosive gas/air (21 percent oxygen) mixtures.
- ▲ Oxygen deficient atmospheres may cause readings of combustible gas lower than actual concentrations.
- ▲ Verify calibration of the combustible gas sensor after use where the combustible gas content causes the instrument to latch in the OVER-RANGE alarm condition.
- ▲ Silicone compound vapors may cause desensitization of the combustible gas sensor and may cause readings of combustible gas to be lower than actual gas concentrations. If the instrument has been used in an area where silicone vapors were previously present, always verify the instrument's calibration before next use to ensure accurate measurements.
- ▲ Sensor aperture areas and water barriers must be kept clean. Obstruction of the sensor aperture areas and/or contamination of the water barriers may cause readings to be lower than actual gas concentrations.
- ▲ High Over-Range (+OR) combustible gas readings may indicate an explosive concentration of combustible gas.
- ▲ Exposure to high or prolonged concentrations of HCN and NH₃ can cause a loss in sensitivity in the respective sensors. Check calibration prior to each use.

2. UNPACKING THE INSTRUMENT

The shipping box should contain the following items.
Account for each item before discarding the box.

QUANTITY	PART NUMBER	DESCRIPTION
1	1810-3606	LTX312 Multi-Gas Monitor
or		
	1810-4067	LTX311 Multi-Gas Monitor
1	1704-1872	Rechargeable Ni-Cad Battery Pack
or		
1	1706-9889	Replaceable Cell Lithium Battery Pack
or		
1	1706-7174	Replaceable Cell 9-Volt Battery Pack
1	1707-4808	LTX311/312 Instrument Manual
1	1810-2201	Leather Carrying Case
1	1705-0278	Maintenance Tool
1	1705-0831	Calibration Cup
1	1704-4157	Teflon-Lined Tygon Tubing

After unpacking, if any listed item is missing, contact either your local distributor of Industrial Scientific products, or call Industrial Scientific Corporation at 1-800-DETECTS (338-3287) in the United States and Canada, or 412-788-4353.

3. LTX311/312 OVERVIEW AND FEATURES

The LTX311/312 Multi-Gas Monitor is designed to simultaneously monitor oxygen levels and the presence of combustible gases and one toxic gas. The unit is capable of monitoring the oxygen (O₂) content of ambient air from 0 to 30 percent in increments of 0.1 percent. The unit accommodates a combustible gas sensor that continually monitors the presence of combustible gases, allowing the unit to display a reading expressed as a percentage of the lower explosive limit (LEL) or percent of volume methane.

An additional toxic gas sensor can be easily installed to allow the LTX311/312 to measure the parts-per-million concentration in ambient air of any of the gases shown in the following table at the indicated ranges.

NOTE: *A carbon monoxide (CO) sensor may be installed in the LTX312 that accurately measures CO levels without errors caused by cross-interfering hydrogen gas.*

GAS	ABBREVIATION	DISPLAY RANGE (parts per million unless otherwise indicated)	MEASUREMENT INCREMENTS (parts per million unless otherwise indicated)
Combustible Gases	LEL	0 to 100% LEL	1%
Oxygen	O ₂	0 to 30%	1%
Methane	CH ₄	0 to 5%	1%
Ammonia	NH ₃	0 to 99	1
Carbon Monoxide	CO	0 to 999	1
Chlorine	Cl ₂	0.2 to 99.9	0.1
Hydrogen Cyanide	HCN	0 to 99	1
Hydrogen Sulfide	H ₂ S	0 to 999	1
Nitric Oxide	NO	0 to 99	1
Nitrogen Dioxide	NO ₂	0.2 to 99.9	0.1
Sulfur Dioxide	SO ₂	0.2 to 99.9	0.1
Hydrogen Chloride	HCl	0.2 to 99.9	0.1
Chlorine Dioxide	ClO ₂	0.2 to 25	0.1

The unit is composed of a two-piece stainless steel case sealed by a rubber gasket. Gas readings and all instrument functions are shown on the LCD display screen on the front of the unit. Directly under the screen are four function keys, two of which are hidden. The key marked “ON/OFF/MODE” turns the unit on and off, and allows the user to step through the modes described in Section 5, **Basic Operation Modes**.

The key marked with an “E” and a light bulb icon also serves a dual purpose: illuminating the display and entering data. Pressing this key in any mode illuminates the display screen for approximately 12 seconds. While setting options in the instrument, the E-key also functions as an enter key.

Above the MODE key and the E-key are hidden “-” and “+” keys that can be felt as raised bumps on the printed panel on the face of the unit. These keys are used to enter values for various instrument setting and to scroll through lists of options in the function menus described in Section 7, Changing Instrument Settings.

The two holes in the front of the unit above and below the MODE and E keys are the alarm speakers.

The LTX311/312 includes these additional features:

- Automatic recognition of installed sensors and sensor configuration when turned on
- External control and calibration controls
- Microprocessor-controlled calibration sequence for accurate calibration
- Illuminated display for viewing in low light conditions
- Choice of power sources (powered by either a rechargeable nickel-cadmium battery pack, a replaceable lithium battery pack, or a battery pack that accepts 9-volt alkaline cells)

WARNING: Do not mix battery types within the same battery pack.

- Plug-in sensors that can be changed without special tools or soldering
- A jack for connecting external alarms
- High- and low-level alarms for combustible and toxic gases, and enrichment and depletion alarms for oxygen
- User-selectable latching alarms
- User-defined security access code
- Press and hold power control to prevent accidentally turning the unit ON and OFF
- Combustible gas over-range protection
- Certification as intrinsically safe –or pending approval–by;
 - Underwriter’s Laboratory (UL)
 - Mine Safety and Health Administration (MSHA) (*LTX311 only*)
 - Canadian Standards Association (CSA)

NOTE: *The Canadian Standards Association has assessed only the combustible gas portion of this instrument for performance.*

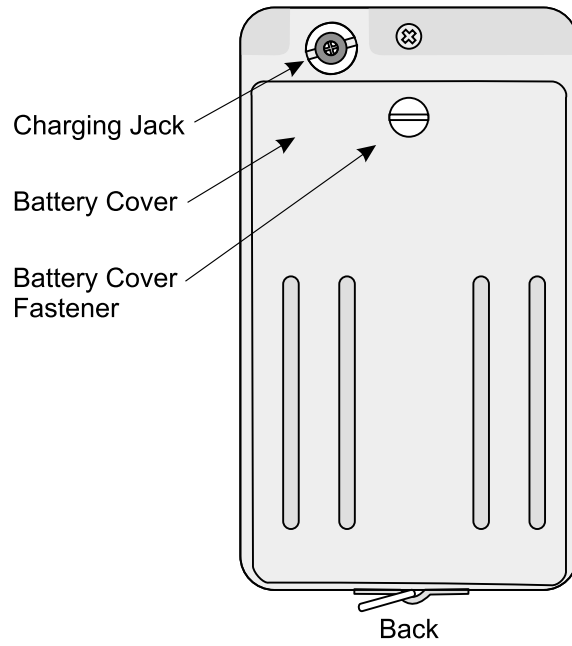
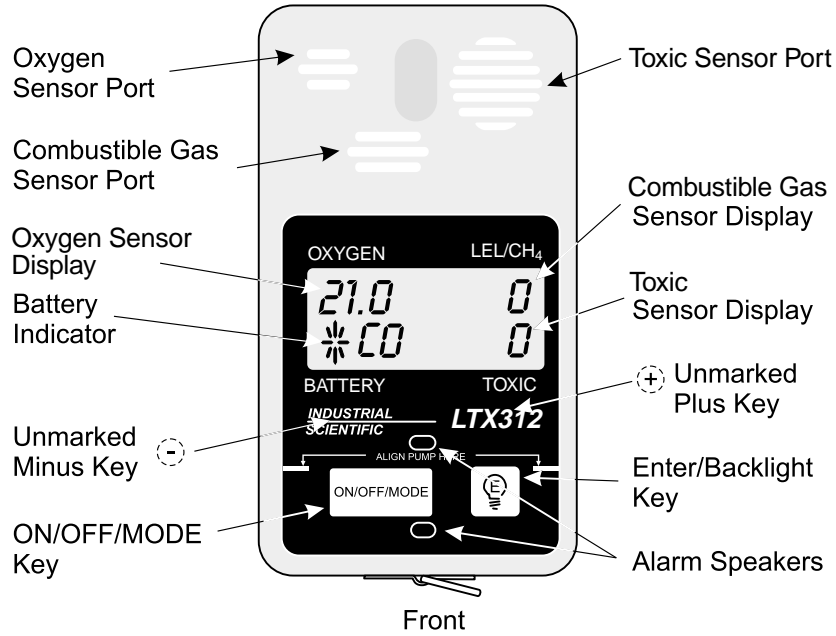

4. BASIC OPERATION

The battery shipped with the unit may or may not be sufficiently charged to permit normal instrument operation. See **Charging the Battery Pack** if charging is necessary.

4.1 TURNING THE LTX311/312 ON



ON/OFF/MODE

Press and hold the MODE key. The instrument will display “HOLD” on its screen and emit a short beep approximately once per second.

When “RELEASE” is displayed on the display screen (after five beeps), release the MODE key and the instrument will begin its startup routine. Refer to **Startup Routine** for additional information.

4.2 TURNING THE LTX311/312 OFF

From any mode of operation, press and hold the MODE key. The instrument will display “HOLD” on its screen and emit a short beep approximately once per second.

When “RELEASE” is displayed on the display screen (after five beeps), release the MODE key and the instrument will turn off.

4.3 STARTUP ROUTINE

Every time the instrument is turned on, it will execute the following startup routine before it is ready to operate:

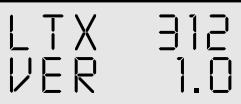

LTX 312
VER 1.0



BATTERY
NORMAL

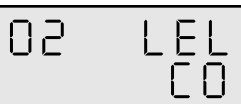

02 LEL
CO



9

- **Instrument and software identification** – the name of the instrument and its software revision are displayed.
- **Battery condition** – the screen will display “BATTERY NORMAL” if the battery is sufficiently charged for normal operation, or “BATTERY LOW” if the battery should be charged.
- **Sensor Configuration** – the sensors currently installed in the instrument and their respective positions on the display screen are displayed.
- **Countdown** – the instrument will countdown from 9 to 0. While the instrument is counting down, setup options can be accessed. See **Changing Instrument Settings** for additional information.

When the countdown reaches zero, the unit will automatically enter Reading Mode and begin continuous gas level monitoring.

5. BASIC OPERATION MODES

The following basic features of the LTX311/312 can be accessed by pressing the MODE key. Each time the MODE key is pressed, the instrument will advance to the next feature in the sequence in which they appear below.

5.1 READING MODE

The LTX311/312 defaults to Reading Mode as soon as the startup routine is complete. In this mode, the instrument displays the gas concentration level recorded by each sensor. Sensor positions are identified during the instrument startup routine and are marked on the face of the unit around the display screen.

NOTE: *Once the instrument has entered Reading Mode after the startup sequence, it will automatically monitor gas levels and signal alarms based on these levels, regardless of which operating mode is selected.*

Reading mode also identifies the battery level of the instrument. An eight-segment battery indicator appears to in the lower left corner of the display. The segments disappear two at a time as battery power is used to visually indicate current battery power. Refer to **Battery Alarms** and **Basic Maintenance and Repair** for additional information about the instrument battery.

NOTE: *If no action is taken in any of the following basic operation modes after advancing from Reading Mode, the instrument will automatically return to the Reading Mode after about 8 seconds.*

5.2 PPM HYDROCARBON MODE (LTX312 ONLY)

PPM Hydrocarbon Mode allows the user to measure hydrocarbon gases with 50 PPM resolution. The total hydrocarbon content of a gas stream will be displayed in 50 PPM increments up to the level of the low LEL alarm setpoint, using Pentane as the standard. If the combustible gas concentration exceeds the low LEL alarm setpoint, the display will automatically return to the normal reading mode.

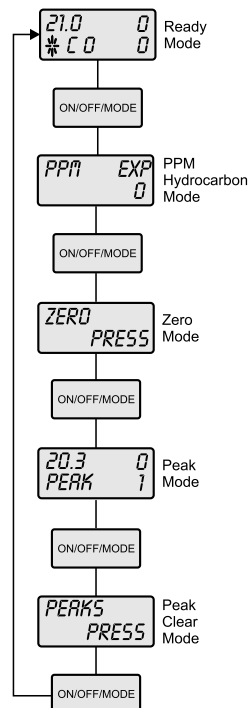

The unit may be optionally configured to display PPM of Methane (CH₄) on this mode. Refer to **Changing Instrument Settings** for more information.

The PPM reading may be zeroed at any time while in this mode by pressing the E-key.

5.2 ZERO MODE

Zero Mode allows the user to establish the zero point from which the instrument measures gas levels. In this mode, the user can also calibrate all installed sensors. For detailed instructions on zeroing and calibrating the instrument sensors, refer to **Sensor Zero and Calibration**.

5.3 PEAK MODE

Peak Mode displays the lowest measured level of oxygen and the highest measured levels of combustible and toxic gases recorded since the peak memory was last cleared.

NOTE: *Peak measurements do not clear when the instrument is turned off. Peak memory must be manually cleared in the Peak Clear Mode (see below).*

5.4 PEAK CLEAR MODE (PEAKS)

Peak Clear Mode allows the peak measurement memory to be cleared.

Press the E-key on the face of the instrument to clear peak measurements of all sensors from the instrument memory. After pressing E, the instrument will automatically return to Peak Mode to indicate that the peak levels have been reset.

6. ALARMS AND OTHER INDICATORS

The LTX311/312 signals the operator of dangerous oxygen and toxic gas levels, low battery conditions, and individual sensor failure by a system of visual and audible alarms, described below. If desired, an additional alarm speaker (see **Optional Parts and Accessories**) may be plugged into the external alarm port to increase the volume of the alarm for the operator and-or to allow others at some distance to see and hear the alarm signal.

6.1 FAULT INDICATION

The fault indication alarm signals that at least one of the installed sensors failed the system test. Reasons for this fault include the following:

- A newly installed sensor has not yet been calibrated (sensors require calibration before they can be operated).
- A sensor has temporarily become disconnected from the circuit board and requires re-seating and re-calibration.
- A sensor's span reading is 50% or less of the setspan value and requires replacement (see **Sensor Zeroing and Calibration** for more information).

When turned on, the instrument signals a fault by the following:

- **Audible indicator** – The instrument emits a short beep approximately every 1.2 seconds.
- **Display indicator** – When the instrument is in Reading Mode, the position of the sensor that is causing the fault appears blank on the screen.

Correcting a faulted sensor requires replacing the sensor, reseating the sensor on the circuit board, and/or calibrating the sensor to allow it to operate. Refer to **Sensor Zeroing and Calibration** and **Replacing Gas Sensors** for further instructions.

6.2 GAS LEVEL ALARMS

Combustible/toxic gas level alarms represent increasing concentrations of combustible and/or toxic gases. The low-level alarm (see below) signals that a certain concentration of gas is present and that caution should be exercised. The high-level alarm (see below) signals that gas concentrations have reached potentially hazardous levels and that actions should be taken accordingly.

Oxygen level alarms delineate a range of acceptable concentrations of oxygen around the 21 percent normally found in ambient air. The low level of this range signals an oxygen deficiency, while the high level of this range signals an oxygen enrichment. Because either of these conditions represent a serious hazard, both high and low oxygen readings trigger high-level alarms to signal that oxygen concentrations are outside the acceptable range.

Refer to **Specifications** for the default low and-high level alarm setpoints for each type of sensor; refer to **Changing Instrument Settings** for instructions on changing these setpoints.

6.3 LOW-LEVEL ALARM

When the instrument detects that a gas being monitored (with the exception of oxygen) has reached the low-level setting, the instrument signals a low-level alarm as follows:

- **Visual indicator** – A red LED will flash through the display screen and the display backlight of the instrument will flash.
- **Audible indicator** – The instrument emits a single tone approximately every 1.2 seconds.
- **Display indicator** – On the display of the instrument, the reading of the gas in alarm will flash on and off.

6.4 HIGH-LEVEL ALARM

When the instrument detects that a gas being monitored has reached the high-level setting (or in the case of oxygen, when the level reaches either the low- or high-range limits), the instrument signals a high-level alarm as follows:

- **Visual indicator** – A red LED will flash through the display screen and the display backlight of the instrument will remain on continuously during the alarm.
- **Audible indicator** – The instrument emits a continuous warbling tone.
- **Display indicator** – On the display of the instrument, the reading of the gas in alarm will flash on and off.

Refer to **Specifications** for specific gas measurement ranges and factory alarm settings.

NOTE: *When the instrument detects that a gas being monitored is exceeding the upper limit of its measuring range, the display will show “+OR” in the position of the gas reading to report an out-of-range condition.*

6.5 COMBUSTIBLE GAS OVER-RANGE

If the combustible gas sensor is exposed to a concentration greater than 100% LEL or 5% CH₄ by volume, the instrument will latch in the high level alarm condition. Power will be removed from the sensor to prevent damage. This condition can be cleared by pressing the (E) key with the instrument in clean air.

6.6 BATTERY ALARMS

6.6.1 BATTERY INDICATOR

Battery life is indicated by the eight-segment indicator displayed in the Reading Mode on the bottom of the display. The segments disappear two at a time as battery power is used to visually indicate current battery power.



Battery
Indicator

6.6.2 LOW BATTERY WARNING

When approximately 1 hour of instrument operation energy remains in the battery, the instrument emits a short beep every 15 seconds. In addition, the battery indicator will be replaced by a flashing “B” on the display.

NOTE: *If there is not enough battery power to operate instrument for 8 hours in startup, the instrument will display “BATTERY LOW” during the startup sequence.*

6.6.3 BATTERY FAILURE

When the battery has insufficient charge to operate the instrument, the instrument will display “BATTERY FAIL” on the screen and emit a short beep once per second.

NOTE: *When battery failure occurs, the instrument stops gas monitoring functions.*

Refer to **Basic Maintenance and Repair** for battery recharging and replacement instructions.

7. CHANGING INSTRUMENT SETTINGS

The LTX311/312 allows the user to customize the instrument’s settings to suit a particular situation or application. There are six setup options that may be changed:

- **Setspan** – Establishes the gas concentration that will be used to calibrate the instrument.
- **Alarms** – Specifies gas concentrations that will trigger low- and high-level alarms.
- **Display** – Allows the user to toggle between Reading and Text modes.
- **Latch** – Allows the user to select whether the alarms will be latching or non-latching.

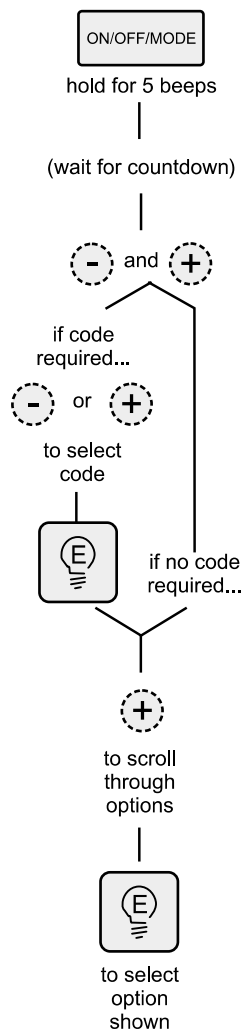

- **Battery** – Allows the user to select what type of battery pack is installed in the unit.
- **Code** – Allows a security code to be set to prevent accidental or unauthorized changes of these settings.

NOTE: *Setup options can only be entered during the countdown in the startup routine.*

Change setup options as follows:

1. Turn the instrument off, if it is already on, and then on again.
2. When the display shows the countdown in progress, simultaneously press the hidden - and + keys located above the ON/OFF/MODE and E-keys.

If a security code has not been designated by an operator (all new instruments have security codes set to zero), the instrument will allow the user to choose which setup option to change.

If a security code has been designated, the CODE prompt will appear. Use the hidden - and + buttons to change the value on the display to match the security code. When the correct security code has been set on the display, press the E-key to enter the code. Refer to **Code** for additional information.

When the correct code is entered, the instrument will allow the user to choose which setup option to change.

3. Use the + key to advance to the setup option that you want to access. Press the E-key to access the option that appears on the display.

Press the MODE key when finished to go to Reading Mode for normal operation of the instrument.

7.1 SETSPAN

When calibrating a sensor, the instrument must know what concentration of gas is being applied to correctly identify that concentration and to establish the scale to which lesser concentrations can be accurately compared and measured (refer to **Sensor Zeroing and Calibration** for additional information). The gas concentration applied during calibration (called the “setspan”) may vary based upon the concentration of gas available.

To adjust the LTX311/312 to accommodate calibration with different known concentrations of a gas, the SETSPAN option allows you to set the instrument to accept a given concentration of gas supplied to the instrument during calibration.

Change the setspan for the gas sensors as follows:

1. From Setup, access the SETSPAN option by pressing E when “SETSPAN” appears on the display.
2. Prior to changing sensor setspan values, you may first change whether the combustible sensor will measure percent LEL or percent methane (CH₄). Use the + key to toggle between the two possible configurations. The display will show “LEL” if the unit is currently set to display percent “LEL”, and “CH₄” if it is set to display percent Methane. Use the MODE key to select the configuration shown on the display and exit the combustible gas sensor configuration option. You may also press the MODE key prior to selecting a value to leave the instrument in its original configuration.

NOTE: *If no combustible gas sensor is installed, proceed to step three.*

3. Use the + key to advance to a gas sensor whose setspan you wish to change and press the E-key.
4. Use the hidden - and + keys to change the setspan of the sensor to the desired value.
5. Press E-key to enter the value displayed as the sensor’s setspan.
6. Use the + key and E-key to select another sensor to change its setspan or press the MODE key to return to SETSPAN OPTION.

Press the MODE key again to return to the Reading Mode for normal operation of the instrument.

7.2 ALARMS

The ALARMS option allows the user to set the gas concentrations at which the instrument will signal low and high alarms during normal operation. Refer to **Specifications** for the gas concentrations at which the instrument is preset to signal alarm.

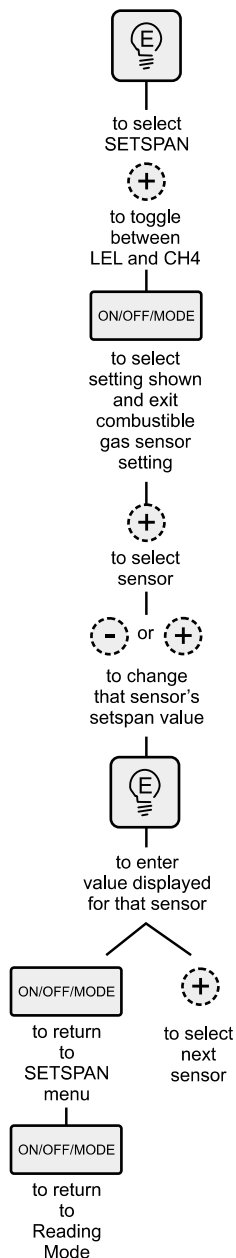

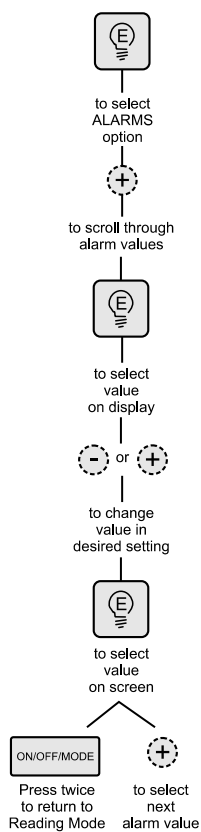

Change the alarm value for a gas as follows:

1. From Setup, access the ALARMS option by pressing the hidden + key until “ALARMS” appears on the display and then press the E-key.
2. Use the hidden + key to advance the display through the low and high alarm values of the available sensors.
3. When the alarm value of the sensor you want to change is displayed, press the E-key to select it. The letters of the gas sensor identifier will blink to indicate that it has been selected.
4. Use the hidden - and + keys to change the alarm value to the desired alarm value.
5. Press E to enter the value shown as the alarm value.
6. The instrument will return to displaying the low- and high-level alarm values of the available sensors. Use the + and E-keys to select another alarm value to change, or press the MODE key twice to return to the Reading Mode for normal operation of the instrument.

7.3 DISPLAY

The DISPLAY option allows the user to select the way information is displayed in the Reading Mode during normal operation. In the default “Reading” option, sensor readings are continuously displayed and updated on the display screen as the unit monitors the ambient air. If the “Text” option is chosen, the unit will not display sensor readings and will only show the name of the installed sensor (for example, “O2” or “CO”) on the display in the same way as they appear during the sensor configuration portion of the startup routine. Both low- and high-level gas alarms will continue to function the same, and the unit will flash the name of the sensor causing the alarm condition.

Change the display option as follows:

1. From Setup, access the DISPLAY option by pressing the hidden + key until “DISPLAY” appears on the display and then press the E key.
2. Press the hidden + key to toggle between “READING” and “TEXT” options on the display.
3. Press the Mode key twice to return to Reading Mode for normal operation of the instrument.

7.4 LATCH

The LATCH option allows the user to change an ON/OFF setting to determine whether the unit's alarms are latching or nonlatching. In the default OFF position, the high level alarms are nonlatching, meaning that the alarm will cease as soon as the gas level that triggered the alarm returns to the acceptable range. In the ON position, the high level alarms become latching, meaning that the alarm will continue to sound even after the gas level that triggered the alarm returns to the acceptable range. In this mode, the user must acknowledge the alarm condition by pressing the E key to cancel the alarm.

Change the latch setting as follows:

1. From Setup, access the LATCH option by pressing the hidden + key until "LATCH" appears on the display and then press the E key.
2. Press the hidden + key to toggle between "ON" and "OFF" options on the display.
3. Press the Mode key twice to return to Reading Mode for normal operation of the instrument.

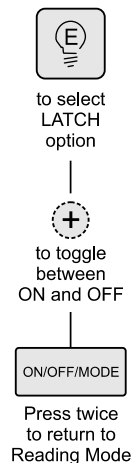

7.5 BATTERY

The BATTERY option allows the user to select the type of battery installed in the unit. The setting configures the battery indicator to accurately display the discharge rate of the selected battery type.

Change the battery setting as follows:

1. From Setup, access the BATTERY option by pressing the hidden + key until "BATTERY" appears on the display and then press the E key.
2. Press the hidden + key to toggle between battery types. The display will show "NCD/LI" for Ni-Cad or lithium batteries and "ALKALNE" for alkaline batteries.
3. Press the E key to select battery type shown.
4. Press the Mode key twice to return to Reading Mode for normal operation of the instrument.

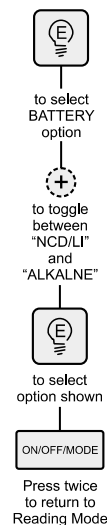

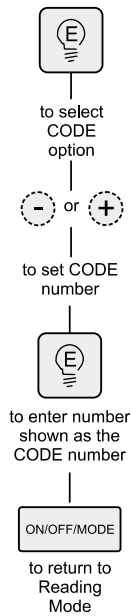

7.6 CODE

To protect the setspan, alarm, and calibration settings from accidental (or unauthorized) changes, the CODE option allows the user to designate a security code. This code will then be requested before access to setup and calibration options is allowed.

Designate a security code for the instrument as follows:

1. From Setup, access the CODE option by pressing the hidden + key until “CODE” appears on the display, and then press the E-key.
2. Use the hidden - and + keys to change the “0” that appears to any number up to three digits.
3. When the number on the screen is the number you want to set as the security code, press the E-key to enter the number.
4. Press the MODE key to return to Reading Mode for normal operation of the instrument.

NOTE: *Setting the code number to zero disables the security code feature.*

8. SENSOR ZEROING AND CALIBRATION

The LTX311/312 is a potential life saving device. Recognizing this fact, Industrial Scientific Corporation recommends that a functional (“bump”) test be performed on every instrument prior to each days use. A functional test is defined as a brief exposure of the monitor to a known concentration of gas(es) for the purpose of verifying sensor and alarm operation and is not intended to be a measure of the accuracy of the instrument.

Industrial Scientific further recommends that a full instrument calibration be performed using a certified concentration(s) of calibration gas(es) monthly to ensure maximum accuracy.

If an instrument fails to operate properly following any functional “bump” test, a full instrument calibration should be performed prior to use.

To detect varying concentrations of gases, the instrument must be periodically adjusted to ensure that it is providing accurate readings. This process of adjustment consists of the following two steps:

- **Zeroing** – Allowing the sensor to detect ambient air that is without the presence of toxic gas. This allows the instrument to set the zero point (bottom) of the measurement scale for the toxic gas sensors.
- **Calibration** – Applying a known concentration of gas to the sensor to allow the instrument to associate a known point on the measurement scale with a detected concentration of gas.

Using these settings as references, the instrument can then accurately measure concentrations of gases which fall within the measuring ranges of the individual sensors. Both zeroing and sensor calibration are simple procedures that can be performed by the user, provided the right calibration gases are available.

8.1 ZEROING

When zeroing the instrument, it is important that the ambient air:

- Has zero concentration of the toxic/combustible gases for the sensors that are installed in the instrument
- Has approximately 21 percent oxygen (as is found in normal air)

If the instrument must be zeroed in ambient air that does not possess these attributes, “zero grade air” should be applied to the instrument from a gas cylinder in the same manner as toxic gases are applied during toxic sensor calibration. Refer to **Calibrating the Toxic/Combustible Gas Sensors** for information about applying gases to the instrument from gas cylinders.

NOTE: *Because zeroing takes place in a known concentration of oxygen, zeroing the instrument also calibrates the oxygen sensor if an oxygen sensor is installed.*

Zero the instrument as follows:

1. From the Reading Mode, press the MODE key until the display shows the ZERO mode.
2. Press the E-key to begin zeroing. The screen will display “ZEROING”.

The screen will display a three-digit number identified as “O2 SPAN.” This is the span reading of the oxygen sensor.

A span reading identifies the sensitivity life left in the sensor. Sensor responsiveness to gas concentrations decreases with age and use.

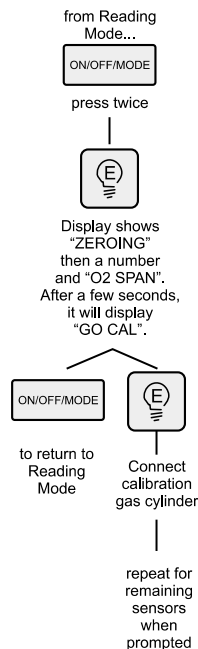

A span reading tests the sensor to determine if its sensitivity is acceptable with respect to the setspan of the sensor (the known quantity of gas that is being applied during calibration). Span readings are interpreted as follows:

- If the span reading of the sensor is 71 percent or greater of the sensor setspan, the sensor sensitivity is acceptable.
- If the span reading is between 51 and 70 percent of the sensor setspan, the instrument will signal a marginal sensor by flashing the sensor reading value for the sensor that is marginal. The sensor is still acceptable for use but should be replaced as soon as possible to ensure accuracy.
- If the span reading of a sensor is below 50 percent of the sensor setspan, the sensor will fail calibration. The sensor is not acceptable for use and must be replaced. The unit will emit a beep approximately once every 1.5 seconds to warn of a failed sensor until a new sensor is installed and calibrated.

For example, because an oxygen sensor setspan is 21 percent, an oxygen span reading

- Of 14.9 or greater would be acceptable,
- Between 10.7 and 14.8 would be marginal but the sensor could still be used
- Under 10.7 would fail and require sensor replacement

3. After displaying the oxygen span reading, the instrument will display “GO CAL”. If you are not calibrating the toxic or combustible gas sensors at this time, you may press the Mode key to return to normal Reading Mode (the instrument will automatically return to the Reading Mode after approximately 8 seconds). If you are calibrating a toxic or combustible gas sensor, press the E-key and refer to **Calibrating the Toxic/Combustible Gas Sensors** for further instructions.

8.2 CALIBRATING THE TOXIC/COMBUSTIBLE GAS SENSORS

After all sensors have been zeroed, the toxic and combustible gas sensors can be calibrated. During sensor calibration, a known concentration of gas is applied to the instrument with the calibration cup and a cylinder containing the appropriate gas for each sensor. Same gases may be combined in a single cylinder to speed the calibration procedure, as long as the cylinder contains the necessary concentration of each gas.

IMPORTANT: Check the label on the calibration gas cylinder to ensure (1) that the cylinder contains the correct concentrations of gas or gases, and (2) that the expiration date of the cylinder has not passed.

IMPORTANT: Since many of the calibration gases are highly reactive, be sure to use only Teflon-lined tubing between the cylinder and the calibration cup.

NOTE: When calibrating individual toxic gas sensors, it is suggested (but not required) that the instrument be calibrated at the temperature at which it is going to be used. It is also strongly suggested that before calibration, the temperature of the instrument is allowed to stabilize for 1 hour at the temperature at which it is going to be calibrated.

NOTE: If you are using the special hydrogen nullifying CO sensor, the instrument must be calibrated with both a known concentration of carbon monoxide and a known concentration of hydrogen separately (twice with each gas). The instrument display will prompt you to when to apply the appropriate gas.

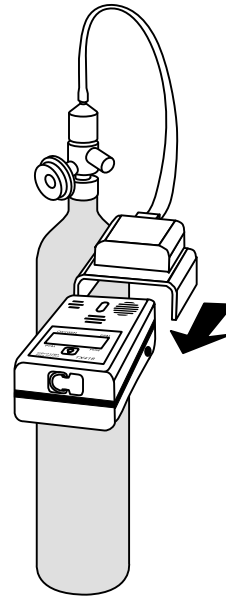

After the instrument has been zeroed, its screen will display “GO CAL”.

Calibrate the toxic/combustible sensors as follows:

NOTE: If the E-key is not pressed, the unit will return to the Reading Mode after about 8 seconds. If you do not wish to calibrate the instrument at this time, you may also press the MODE key to return to the Reading Mode.

1. Press the E key at the GO/CAL prompt.

The unit will display the first sensor to be calibrated along with the span gas value, and the message “APPLY CAL GAS” will scroll across the bottom of the display.

2. Slide the calibration cup over the unit, connect the calibration gas cylinder for the first sensor, and open the cylinder valve.

When the instrument senses a concentration greater than 50% of the setspan value, the display will show the current span value for that sensor, and the message “CAL IN PROCESS” will scroll across the bottom of the display.

NOTE: The unit will wait for 5 minutes to sense that the calibration gas has been applied before aborting and failing calibration.

When calibration of the sensor has been successfully completed, the instrument will automatically advance to the next sensor to be calibrated. The unit will display the sensor name along with the setspan value, and the message APPLY CAL GAS will scroll across the bottom of the display.

3. Turn off the previous calibration gas, attach the appropriate calibration gas cylinder to the calibration cup line, and open the valve.
4. Repeat this procedure for the remaining sensor.

When all the sensors have been successfully calibrated, the sensor configuration will be shown on the display. Sensor identifiers will flash to warn of any sensors with marginal span values.

NOTE: *You may calibrate only selected sensors if desired by pressing the MODE key to step out of Calibration Mode after the last sensor you wish to calibrate has successfully calibrated.*

After displaying the sensor configuration, the instrument will automatically return to the Reading Mode.

IMPORTANT: *The instrument will almost always display and sound an alarm for a few seconds after returning to the Reading Mode after calibration. This is normal. The reading functions are temporarily suspended during calibration and are reactivated upon returning to Reading Mode. As soon as residual calibration gases dissipate from the sensors, the alarm will turn off, unless the unit has the alarm latch activated.*

9. REMOTE SAMPLING

Using the optional SP402 Remote Sampling Pump, the LTX311/312 may be used to analyze environments at short distances prior to entering. A typical use for this capability would be sampling the environment beneath a service manhole prior to repair or service personnel descending into the manhole. Because there are many regulations that govern acceptable sampling methods in this and other situations, you should check with your supervisor or other personnel prior to performing a remote sampling test. The following instructions are provided only to outline the basic procedure.

1. With the LTX311/312 switched ON and in normal Reading Mode, loosen the velcro straps on the sampling pump and slide the pump housing over the instrument as shown. When properly aligned, the unit should be snug against the front of the sampling pump with the alignment mark level with the brackets on the pump.
2. Pull the velcro straps tight and press the velcro portions of the straps together firmly to ensure a good hold.
3. With the unit mounted, push one end of the tubing supplied with the pump onto the nipple at the top of the pump.
4. Pass the other end of the tubing into the environment to be sampled and switch the pump on. The pump will emit a short beep and light both the red and green lights momentarily as a self-test. The red light should then go out, leaving the green light illuminated to show proper operation.

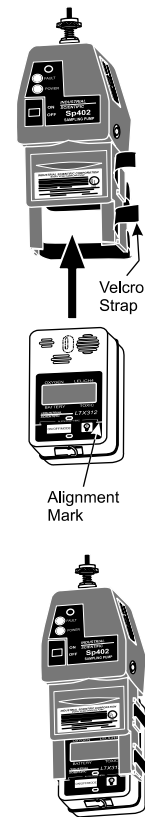

NOTE: *If the line should become clogged or constricted in any way, the red light will glow and the pump will emit a continuous tone to alert the user of a problem. Once the problem is resolved, the unit will automatically begin normal sampling.*

10. BASIC MAINTENANCE AND REPAIR

10.1 CLEANING

Wipe the outside of the instrument with a soft, clean cloth. never use any solvents or cleaning solutions of any type.

10.2 CHARGING THE BATTERY PACK

Battery life depends upon a number of factors such as ambient temperature and the number and duration of alarm activations. Generally, however, the instrument will operate continuously for approximately 10 hours on a fully charged Ni-Cad battery pack, and approximately 11 hours on a fully charged alkaline battery pack.



WARNING: Recharge the Ni-Cad battery pack only in nonhazardous locations. Recharging in the presence of combustible gases could cause an explosion or fire.

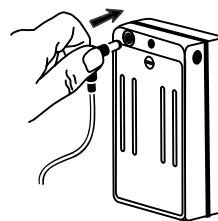



WARNING: Do not recharge alkaline batteries in or out of the unit. This may cause a fire, explosion, and/or severe damage to the instrument.

The Ni-Cad battery pack may be charged in the unit using the charger provided, or outside the unit using any of a number of chargers (see **Optional Parts and Accessories**).

To charge the battery with the charger provided, plug one of the two leads on the charging adapter or the charging jack on the unit on the upper left side of the rear of the unit. The LED on the charger should glow to indicate that the battery is charging.

As with all Ni-Cad batteries, repeated charging when the unit is only partially drained will build up a “chemical memory” in the battery, which effectively reduces its overall capacity. At least once every 30 charging cycles fully discharge the battery by letting it run until “BATTERY FAIL” is indicated on the screen and the unit emits a short beep once per second (see **Battery Alarms**). Various chargers are available which can quickly discharge the battery before charging it (see **Optional Parts and Accessories**).

10.3 REPLACING THE BATTERY PACK

Battery Cover

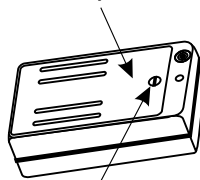

Battery Cover Fastener

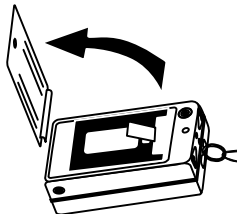

1. Using a flat-bladed screwdriver, unscrew the large batter cover screw on the rear of the unit and remove the cover.
2. Carefully pull the battery pack straight out of the unit using the plastic tab provided.
3. Insert the new battery pack with the contacts facing toward the instrument. Push the battery straight back to until it is fully seated in the instrument.
4. To replace the cover, line up with the edges of the instrument and hook the flange on the bottom of the cover into the bottom of the opening on the instrument and press down. While holding the cover down, tighten the battery cover screw.

10.4 REPLACING THE GAS SENSORS

The positions of the oxygen, combustibile and toxic sensors are unique and cannot be interchanged with one another or with any other location. The space on the circuit board for the toxic gas sensor allows a number of sensors to be installed.

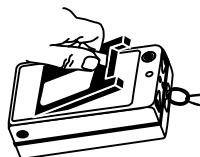

See the Calibration Certificate that comes with the unit for further information and your specific unit's sensor configuration.

Replace a sensor as follows:

1. Remove the battery pack as described above (see **Replacing the Battery Pack**).
2. Remove the two phillips-head screws: one on the back of the unit next to the charging jack, and the other underneath the battery.
3. While holding one half of the unit in each hand, separate the case halves until they are just clear of one another. Place the front cover face down next to the instrument.

NOTE: *The case halves are connected by a flex cable. Be careful when separating the case halves that you do not damage the flex cable.*

4. Before removing a sensor, note the position of any visible connection pins. Remove the desired sensor by pulling straight up.

NOTE: *If a 4-pin toxic gas sensor is removed for storage, insert the shorting wire spring that came with the sensor. If this is not available, use a suitable piece of conductive wire to short the pins shown in the illustration. If this is not done, the sensor will become unstable and require some time after being reinstalled to become operational again. Do not install a shorting wire if the sensor is an NO, NH₃ or HCL type sensor.*

5. Some new sensors are shipped with a shorting wire or bias board attached. Remove the shorting wire or bias board and insert the new sensor in the same position as the old one, fully seating it on the contacts on the circuit board. Hold the new sensor by the sides; never apply pressure on top of the sensor. Be careful not to bend the sensor pins.

NOTE: *Install the new sensor immediately after removing the shorting wire or bias board. If the sensor is allowed to remain outside the unit without the shorting wire, it will become unstable and require some time after being reinstalled to become operational again.*

NOTE: *If you are installing an NO, NH₃ or HCl sensor for the first time or are replacing one of these types with a different gas sensor, you must also change the bias jumpers on the main circuit board.*

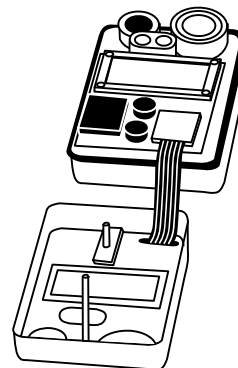
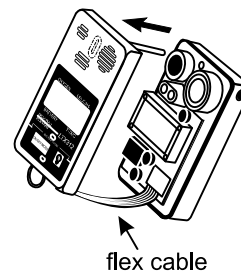

Short these two pins.

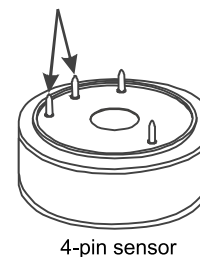

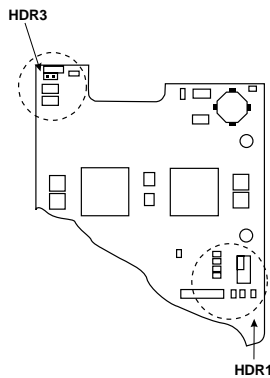

Refer to the Figure and Table Below for appropriate jumper selections.

SENSOR TYPE	JUMPER SELECTIONS	
CO, H ₂ S, SO ₂ , NO ₂	HDR1	HDR3
CL ₂ , HCN, CLO ₂	Pos 1-2	Pos 1-2
HCl	Pos 3-4	Pos 3-4
NO	Pos 5-6	Pos 3-4
NH ₃	Pos 7-8	Pos 3-4

6. Lower the empty case half over the side containing the circuit board. Be sure the lineup pins pass through the holds in the circuit board. Make sure the rubber gasket between the case halves fits around both halves of the instrument case and is not pinched.
7. Install and tighten the two case screws removed in step 2.
8. Install the battery pack and battery cover as described above.
9. Calibrate any sensors that were removed or replaced according to the procedure described under **Sensor Zeroing and Calibration**.

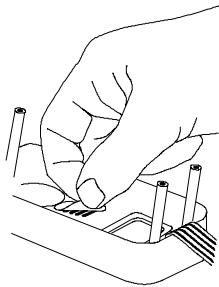

10.5 REPLACING THE SENSOR WATER BARRIERS

If the unit is exposed to dirt, water, or other contaminant's, replace the felt filter membrane as follows:

1. Remove the battery cover as described above (see **Replacing the Battery Pack**)
2. Open the unit case as described above (see **Replacing the Toxic Gas Sensors**).
3. Carefully peel the self-adhesive oxygen and LEL sensor seals from the inside of the case.
4. Carefully peel the self-adhesive gortex water barriers from the inside of the case.
5. Clean the case grills using a soft, clean cloth.
6. Apply new self-adhesive gortex water barriers over the case grills, ensuring that they cover the case openings completely and replace the oxygen and LEL sensor pads.
7. Reassemble the unit case as described above (see **Replacing the Toxic Gas Sensors**).
8. Refit the battery and battery cover (see **Replacing the Battery Pack**).

11. **REPLACEMENT PARTS**

The following items numbers refer to the exploded view drawing on pages 28 and 29.

ITEM	PART NUMBER	DESCRIPTION (QTY)
1	1707-3123	Main PCB
2	1707-3115	Sensor PCB
3	1706-9865	Key Pad
4	1707-2687	Case Top
5	1705-0381	Case Bottom
6	1707-3859	Battery Cover Bracket
7	1707-4253	Battery Cover Bracket Spacer
8	1707-2356	Buzzer Adapter
9	1705-0295	RFI Screen
10	1704-9967	Sensor PCB Support
11	1703-1782	Case Gasket
12	1704-2151	Charging Jack
13	1702-8374	External Alarm Jack
14	1704-9817	Charging Socket Spring
15	1705-0254	Contact Rivet
16	1707-2364	Buzzer Seal
17	1707-2455	Buzzer Membrane
18	1704-9925	Water Barrier, Oxygen Sensor
19	1704-9926	Water Barrier, LEL Sensor
20	1704-9927	Water Barrier, Toxic Sensor
21	1705-0245	Water Barrier, Buzzer
22	1704-9919	Seal, Oxygen Sensor
23	1704-9920	Seal, LEL Sensor
27	1704-9876	Wrist Strap
29	1704-9988	External Alarm Contact
30	1705-0273	Screw, 4-40 x 0.188, Phillips
31	1704-9736	Conductive Transfer Tape
32	1707-4550	Battery Cover
34	1705-0277	O-ring, 0.250 ID
35	1704-1708	O-ring, 0.301 ID
36	1702-9273	External Alarm Jack Plug
40	1706-8701	Battery Spacer
41	1705-0453	Screw, 2-56 x 0.188, Phillips
42	1703-1774	Screw, 4-40 x 0.25, Phillips

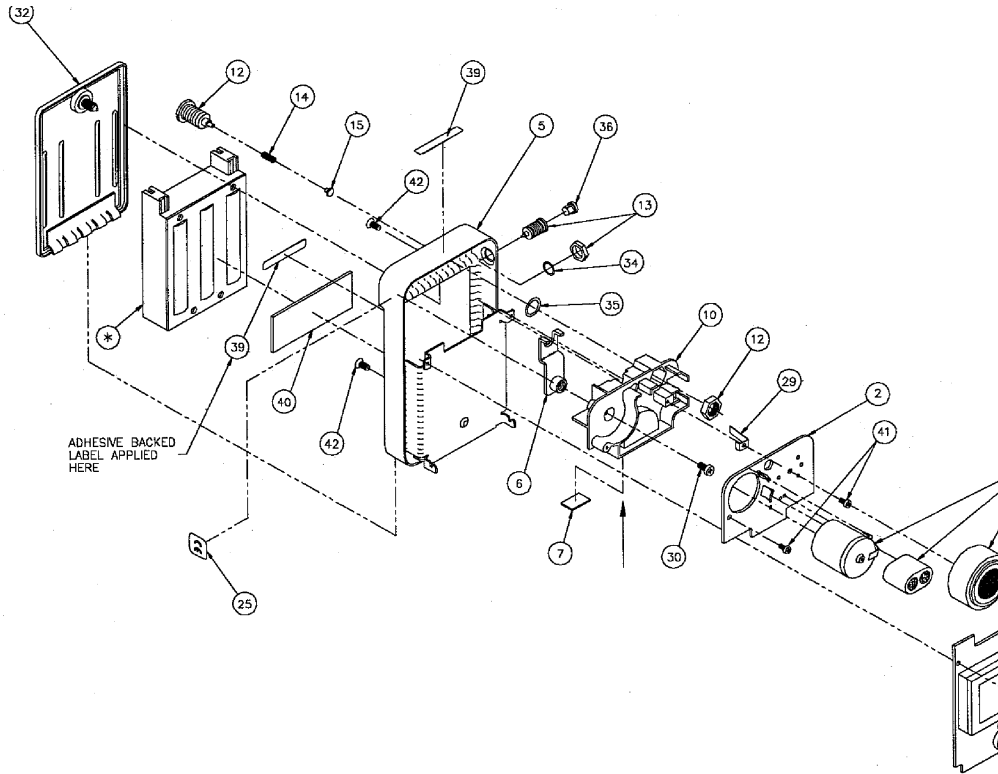

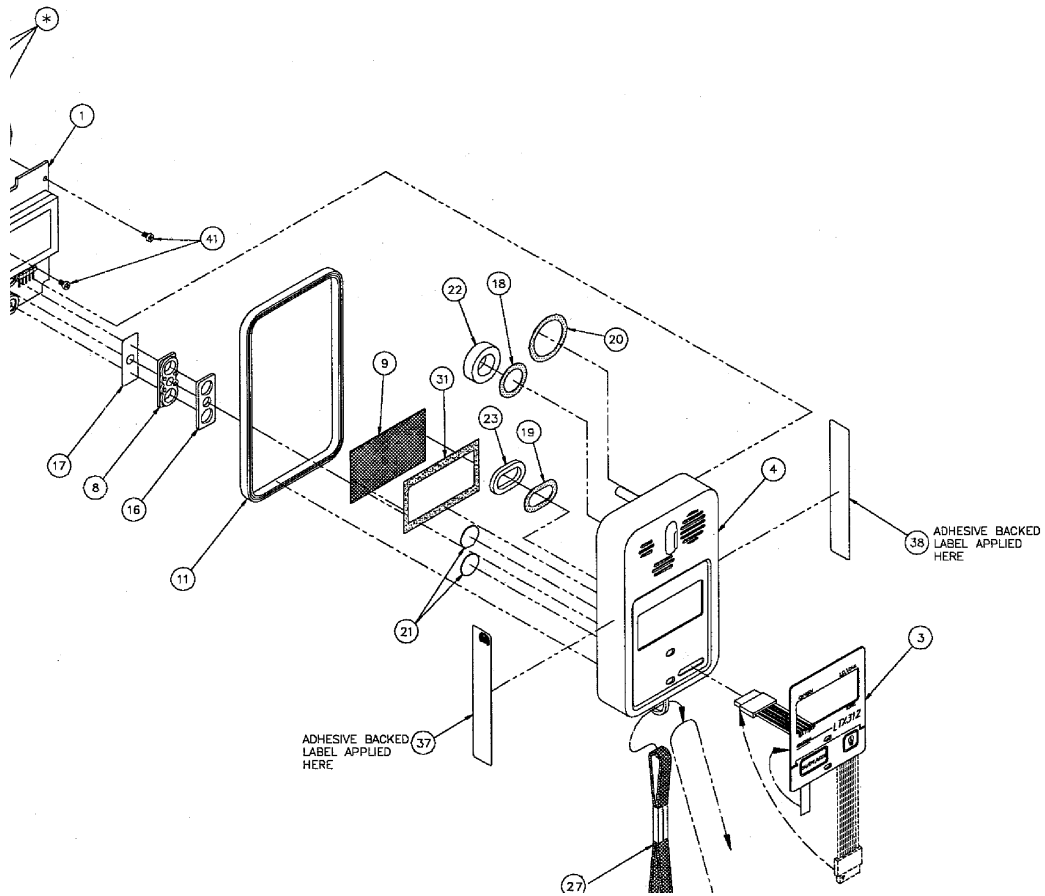

12. SPECIFICATIONS

CASE: Stainless Steel
DIMENSIONS: 4.75 x 2.75 x 2 inches
(121 x 70 x 51 mm)
WEIGHT: 26 ounces (738 grams)
SENSORS: Oxygen, Combustible Gases and Toxic Gases
(electrochemical)

MEASURING RANGE:

Combustible Gases (LEL)
0 to 100% LEL in 1% increments

Oxygen (O₂)
0 to 30% of volume in 0.1% increments

Methane (CH₄)
0 to 5% in 1% increments

Ammonia (NH₃)
0 to 99 PPM (parts per million) in 1 PPM increments

Carbon Monoxide (CO)
0 to 999 PPM (parts per million) in 1 PPM increments

Chlorine (CL₂)
0.2 to 999 PPM (parts per million) in 0.1 PPM increments

Hydrogen Cyanide (H₂S)
0 to 99 PPM (parts per million) in 1 PPM increments

Hydrogen Sulfide (HCN)
0 to 999 PPM (parts per million) in 0.1 PPM increments

Nitric Oxide (NO)
0 to 999 PPM (parts per million) in 1 PPM increments

Nitric Dioxide (NO₂)
0.2 to 99.9 PPM (parts per million) in 0.1 PPM increments

Sulfur Dioxide (SO₂)
0.2 to 99.9 PPM (parts per million) in 0.1 PPM increments

Hydrogen Chloride (HCl)
0.2 to 99.9 PPM (parts per million) in 0.1 PPM increments

Chlorine Dioxide (ClO₂)
0.2 to 25 PPM (parts per million) in 0.1 PPM increments

POWER SOURCE: Rechargeable, replaceable nickel-cadmium battery pack, or replaceable cell alkaline battery pack

BATTERY LIFE: Ni-Cad: Approximately 10 Hours
Alkaline: Approximately 11 Hours

READOUT: Alpha-Numeric Liquid Crystal Type

OPERATING

TEMPERATURE RANGE: -20°C to 55°C (-4°F to 131°F)

HUMIDITY RANGE: 15% to 99% RH (Non-condensing)

STORAGE TEMPERATURE: 0°C to 20°C (32°F to 68°F)

13. DEFAULT ALARM SETTINGS

GAS	LOW ALARM	HIGH ALARM
LEL	10%	20%
O ₂	19.5%	23.5%
CH ₄	1.0%	1.5%
NH ₃	25 PPM	50 PPM
CO	35 PPM	70 PPM
Cl ₂	0.5 PPM	1.0 PPM
H ₂ CN	5.0 PPM	10 PPM
H ₂ S	10 PPM	20 PPM
NO	25 PPM	50 PPM
NO ₂	3.0 PPM	6.0 PPM
SO ₂	2.0 PPM	4.0 PPM
HCl	5.0 PPM	10.0 PPM
ClO ₂	0.3 PPM	1.0 PPM

14. OPTIONAL PARTS AND ACCESSORIES

PART NUMBER	DESCRIPTION (QTY)
1705-0788	PPM Combustible Sensor (LTX312)
1704-1856	Combustible Sensor (LTX311)
1702-3516	Oxygen Sensor
1704-1898	Hydrogen Sulfide Sensor
1704-1880	Carbon Monoxide Sensor
1706-7547	Hydrogen Nullifying Carbon Monoxide Sensor
1707-3271	Chlorine Sensor
1704-1922	Nitrogen Dioxide Sensor
1704-1906	Sulfur Dioxide Sensor
1707-1085	Ammonia Sensor
1707-7470	Hydrogen Cyanide Sensor
1704-9904	Nitric Oxide Sensor
1707-7397	Hydrogen Chloride Sensor
1810-2252	115 VAC Compact Economy Charger
1810-2251	115 VAC Two-Unit Compact Charger
1810-1873	115 VAC One-Unit Dual Rate Charger
1810-2255	115 VAC Four-Unit Dual Rate Charger
1810-1972	230 VAC One-Unit Dual Rate Charger
1810-1899	12 VDC Two-Unit Dual Rate Charger
1810-2156	SP402 Sampling Pump with Hose (UL)
1810-2169	SP402 Sampling Pump with Hose (CSA)
1810-2284	Hand Pump with Hose
1810-1386	Stainless Steel Extendible Probe - 6ft.
1704-1872	Rechargeable Nicad Battery Pack
1704-9889	Replaceable Lithium Battery Pack (includes 3)
1704-7747	Replacement Lithium Battery Cell
1706-7174	Alkaline Battery Pack
1810-2160	Leather Carrying Case for LTX311/312
1810-2161	Leather Combination Carrying Case for SP402/LTX311/312
1810-2177	Leather Handle for 1810-2161 Carrying Case
1810-3747	External Audible/Visual Alarm
1810-2146	Vibrating Alarm
1810-1576	Cylinder, Cal Gas, Carbon Monoxide, Pentane and Oxygen
1810-2165	Cylinder, Cal Gas, Carbon Monoxide, Methane and Oxygen
1810-1584	Cylinder, Cal Gas, Zero Air
1810-2222	Cylinder, Cal Gas, 5 PPM Sulfur Dioxide
1810-1758	Cylinder, Cal Gas 10 PPM Chlorine
1810-2219	Cylinder, Cal Gas 5 PPM Nitrogen Dioxide
1810-2151	Cylinder, Cal Gas 25 PPM Ammonia
1810-2152	Cylinder, Cal Gas 10 PPM Hydrogen Cyanide
1810-2153	Cylinder, Cal Gas 25 PPM Nitric Oxide
1810-1766	Flow Regulator with Pressure Gauge for all Cylinders except Ammonia
1810-2155	Flow Regulation for Ammonia Cylinder
1704-4157	Teflon Tubing (18" w/Hose Barb Adapters)
1705-0831	Calibration Cup

15. WARRANTY

Industrial Scientific Corporation portable gas monitoring instruments are warranted to be free from defects in material and workmanship for as long as the instrument is in service.

The above warranty does not include sensors, battery packs, internal pumps or filters, all of which are warranted to be free from defects in material and workmanship for 18 months from the date of shipment, or 1 year from the date of first use, whichever occurs first, except where otherwise stated in writing in Industrial Scientific literature accompanying the product.

All other Industrial Scientific products are warranted to be free from defects in material and workmanship for a period of 18 months from the date of shipment, 1 year from the date of first use, whichever occurs first, except where otherwise stated in writing in Industrial Scientific literature accompanying the product.

LIMITATION OF LIABILITY

INDUSTRIAL SCIENTIFIC MAKES NO OTHER WARRANTIES, EITHER EXPRESSED OR IMPLIED, INCLUDING BUT NOT LIMITED TO THE WARRANTIES OF MERCHANTABILITY OR FITNESS FOR PARTICULAR PURPOSE.

SHOULD THE PRODUCT FAIL TO CONFORM TO THE ABOVE WARRANTY, BUYER'S ONLY REMEDY AND INDUSTRIAL SCIENTIFIC'S ONLY OBLIGATION SHALL BE, AT INDUSTRIAL SCIENTIFIC'S SOLE OPTION, REPLACEMENT OR REPAIR OF SUCH NON-CONFORMING GOODS OR REFUND OF THE ORIGINAL PURCHASE PRICE OF THE NON-CONFORMING GOODS. IN NO EVENT WILL INDUSTRIAL SCIENTIFIC BE LIABLE FOR ANY OTHER SPECIAL, INCIDENTAL OR CONSEQUENTIAL DAMAGES, INCLUDING LOSS OF PROFIT OR LOSS OF USE, ARISING OUT OF THE SALE, MANUFACTURE OR USE OF ANY PRODUCTS SOLD HEREUNDER WHETHER SUCH CLAIM IS PLEADED IN CONTRACT OR IN TORT, INCLUDING STRICT LIABILITY IN TORT.

It shall be an express condition to Industrial Scientific's warranty that all products be carefully inspected for damage by Buyer upon receipt, be properly calibrated for Buyer's particular use, and be used, repaired, and maintained in strict accordance with the instructions set forth in Industrial Scientific's product literature. Repair or maintenance by non-qualified personnel will invalidate the warranty, as will the use of non-approved consumables or spare parts. As with any other sophisticated product, it is essential and a condition of Industrial Scientific's warranty that all personnel using the products be fully acquainted with their use, capabilities and limitations as set forth in the applicable product literature.

Buyer acknowledges that it alone has determined the intended purpose and suitability of the goods purchased. It is expressly agreed by the parties that any technical or other advice given by Industrial Scientific with respect to the use of the goods or services is given without charge and at Buyer's risk; therefore, Industrial Scientific assumes no obligations or liability for the advice given or results obtained.

P/N 1707-4808
REV 02 Printed 1100-2500
Specifications Subject to Change

GUARANTEED.

FOR LIFE.

1001 Oakdale Road, Oakdale, PA 15071-1500
(412) 788-4353 • Toll Free 1-800-DETECTS
FAX 412-788-8353 • Service Dept. 1-888-788-4353

INDUSTRIAL SCIENTIFIC

CORPORATION