



**Reference
Manual**

**MultiVision
Gas Detector**



**Sperian Instrumentation
651 South Main Street
Middletown, CT 06457
800 711-6776 860 344-1079
Fax 860 344 -1068
24SEPT2008
P/N 13-230 Version 2.01
<http://www.biosystems.com>**

WARNING

**MULTIVISION PERSONAL PORTABLE GAS DETECTORS
HAVE BEEN DESIGNED FOR THE DETECTION AND
MEASUREMENT OF POTENTIALLY HAZARDOUS
ATMOSPHERIC CONDITIONS**

**IN ORDER TO ASSURE THAT THE USER IS PROPERLY
WARNED OF POTENTIALLY DANGEROUS ATMOSPHERIC
CONDITIONS, IT IS ESSENTIAL THAT THE INSTRUCTIONS
IN THIS REFERENCE MANUAL BE READ, FULLY
UNDERSTOOD, AND FOLLOWED.**

**MultiVision
Reference Manual
Sperian Instrumentation Part Number 13-230
Version 2.01
Copyright 2008
by
Sperian Instrumentation, LLC
Middletown, Connecticut 06457**

All rights reserved.

**No page or part of this operation manual may be reproduced in any form
without written permission of the copyright owner shown above.**

Sperian Instrumentation reserves the right to correct typographical errors

Table of Contents

Certification Information	4
Operating Temperature	4
Signal Words	5
Warnings and Cautions	5
1. Description	7
1.1 Methods of sampling	7
1.2 Multi-sensor capability	7
1.3 Calibration	7
1.4 Alarm logic	7
1.4.1 Atmospheric hazard alarms	8
1.4.2 Low battery alarms	8
1.4.3 Sensor over range alarms	8
1.4.4 LEL response failure due to lack of O ₂ alarm	9
1.4.5 Security Beep/Flash	9
1.4.6 Other alarms and special microprocessor features	9
1.5 Other electronic safeguards	9
1.6 Sensors	9
1.7 Built-in sample draw pump	9
1.8 Black box data recorder	10
1.9 MultiVision design components	10
1.10 MultiVision standard accessories	11
1.10.1 Alkaline MultiVision detectors	11
1.10.2 NiMH MultiVision detectors	11
1.11 MultiVision kits	11
1.11.1 MultiVision Confined Space Kits	11
1.11.2 MultiVision Value Packs	11
2. Basic Operations	11
2.1 Turning the MultiVision On	11
2.1.1 Start up with pump	12
2.2 Operating Logic	13
2.3 Turning the MultiVision Off	14
2.4 Alarms	14
2.4.1 Warning Alarms	14
2.4.2 Danger Alarms	14
2.4.3 TWA Alarms	14
2.4.4 Low battery alarms	14
2.4.5 Sensor over range alarms	15
2.4.6 LEL failure due to lack of oxygen alarm	15
2.5 PC connection via infrared port	15
2.5 Error Messages	15
3. Sampling	15
3.1 Manual sample draw kit	16
3.1.1 Manual sample draw kit usage	16
3.2 Motorized sample draw pump	16
3.2.1 Starting the motorized sample pump	17
3.2.2 Turning off the pump	17
3.2.2 Low flow alarm	17
3.3 Sample draw probe	18
4. Calibration	18
4.1 Functional (Bump) testing	19
4.2 Fresh Air/Zero Calibration	19

4.2.1	Fresh air calibration failure.....	20
4.2.2	Manual fresh air / zero calibration.....	20
4.3	Span Calibration.....	21
4.3.1	Span calibration failure: toxic and LEL sensors.....	21
4.3.2	Span calibration failure: oxygen sensors.....	22
4.4	How to calibrate the MultiVision in contaminated air.....	23
5.	Basic Maintenance.....	23
5.1	Cleaning.....	23
5.2	Storage.....	23
5.3	Batteries.....	23
5.4	Replacing alkaline batteries.....	23
5.5	Maintaining NiMH battery packs.....	24
5.5.1	Storage guidelines for the NiMH battery.....	24
5.5.2	Charging guidelines for NiMH battery.....	24
5.5.3	Charging procedure for NiMH battery.....	24
5.6	Sensor installation.....	25
5.7	Sample probe assembly.....	25
5.7.1	Changing sample probe filters.....	26
5.7.2	Changing sample probe tubes (wands).....	26
5.8	Exploded view and replacement parts list.....	27
	Appendices.....	28
	Appendix A Toxic gas measurement – Warning, Danger, STEL and TWA alarms.....	28
1.	Warning and Danger Alarms:.....	28
2.	Time Weighted Average (TWA):.....	28
3.	Short Term Exposure Limits (STEL):.....	28
	Appendix B Calibration Frequency Recommendation.....	29
	Appendix C MultiVision Sensor Information.....	30
	Appendix D Toxic Sensor Cross-Sensitivity.....	30
	Appendix E Basic parts list.....	30
	Calibration accessories.....	30
	Sensors.....	30
	Miscellaneous.....	30
	Appendix F Sperian Instrumentation Standard Gas Detection Warranty.....	31

Certification Information

The MultiVision carries the following certifications:

UL Class I Division 1 Groups A,B,C,D Temp Code T4

ATEX Certification: II 2G EEx ia d IIC T4

UL International DEMKO A/S 03 ATEX 0245421X

CSA Class I, Division 1, Groups A, B, C, D Temp Code T3C

Operating Temperature

⚠WARNING The MultiVision's operating temperature range is printed on the label on the back of the instrument. Use of Sperian Gas Detectors outside of the instrument's specified operating temperature range may result in inaccurate and potentially dangerous readings.

Signal Words

The following signal words, as defined by ANSI Z535.4-1998, are used in the MultiVision Reference Manual.

⚠ DANGER indicates an imminently hazardous situation which, if not avoided, will result in death or serious injury.

⚠ WARNING indicates a potentially hazardous situation which, if not avoided, could result in death or serious injury.

⚠ CAUTION indicates a potentially hazardous situation, which if not avoided, may result in moderate or minor injury.

CAUTION used without the safety alert symbol indicates a potentially hazardous situation which, if not avoided, may result in property damage.

Warnings and Cautions

1. **⚠ WARNING** The MultiVision personal, portable gas detector has been designed for the detection of dangerous atmospheric conditions. An alarm condition indicates the presence of a potentially life-threatening hazard and should be taken very seriously.
2. **⚠ WARNING** In the event of an alarm condition it is important to follow established procedures. The safest course of action is to immediately leave the affected area, and to return only after further testing determines that the area is once again safe for entry. Failure to immediately leave the area may result in serious injury or death.
3. **⚠ WARNING** Use only Duracell MN1500 or Ultra MX1500, Eveready Energizer E91-LR6, Eveready EN91, Radio Shack 23-874* size AA 1.5V Alkaline batteries, Eveready CH15* or Radio Shack 23-149* size AA NiCad batteries, or Eveready L91*† AA 1.5V Lithium batteries. Substitution of batteries may impair intrinsic safety.

*Not for use with ATEX certified instruments. (ATEX is a European safety directive).

†Not CSA approved (CSA is the Canadian Standards Association (similar to UL in the United States)).

4. **⚠ WARNING** The accuracy of the MultiVision should be checked periodically with known concentration calibration gas. Failure to check accuracy can lead to inaccurate and potentially dangerous readings.
5. **⚠ WARNING** The accuracy of the MultiVision should be checked immediately following any known exposure to contaminants by testing with known concentration test gas before further use. Failure to check accuracy can lead to inaccurate and potentially dangerous readings.
6. **⚠ WARNING** A sensor that cannot be calibrated or is found to be out of tolerance should be replaced immediately. An instrument that fails calibration may not be used until testing with known concentration test gas determines that accuracy has been restored, and the instrument is once again fit for use.
7. **⚠ WARNING** Do not reset the calibration gas concentration unless you are using a calibration gas concentration that differs from the one that is normally supplied by Sperian Instrumentation for use in calibrating the MultiVision. Customers are strongly urged to use only Sperian calibration materials when calibrating the MultiVision. Use of non-standard calibration gas and/or calibration kit components can lead to dangerously inaccurate readings and may void the standard Sperian Instrumentation warranty.
8. **⚠ WARNING** Use of non-standard calibration gas and/or calibration kit components when calibrating the MultiVision can lead to inaccurate and potentially dangerous readings and may void the standard Sperian Instrumentation warranty.

Sperian Instrumentation offers calibration kits and long-lasting cylinders of test gas specifically developed for easy MultiVision calibration. Customers are

strongly urged to use only Sperian calibration materials when calibrating the MultiVision.

9. **⚠WARNING** Substitution of components may impair intrinsic safety.
10. **⚠WARNING** For safety reasons this equipment must be operated and serviced by qualified personnel only. Read and understand this reference manual before operating or servicing the MultiVision.
11. **⚠WARNING** A rapid up-scale reading followed by a declining or erratic reading may indicate a hazardous combustible gas concentration that exceeds the MultiVision's zero to 100 percent LEL detection range.

1. Description

The MultiVision is a four-sensor gas detector that can be configured to meet a wide variety of requirements. This chapter provides an overview of many of the features of the MultiVision. More detailed descriptions of the specific features of the MultiVision are contained in the subsequent chapters of this manual.

1.1 Methods of sampling

The MultiVision may be used in either diffusion or sample-draw mode. In either mode, the gas sample must reach the sensors for the instrument to register a gas reading. The sensors are located beneath the sensor cover plate at the top of the instrument.

In diffusion mode, the atmosphere being measured reaches the sensors by diffusing through vents in the sensor compartment cover. Normal air movements are enough to carry the sample to the sensors. The sensors react quickly to changes in the concentrations of the gases being measured. Diffusion-style operation monitors only the atmosphere that immediately surrounds the detector.

The MultiVision can also be used to sample remote locations with the optional hand-aspirated sample-draw kit or with the optional built-in, motorized, continuous sample draw pump. During remote sampling, the gas sample is drawn into the sensor compartment through the probe assembly and a length of tubing. Remote sampling operations monitor the atmosphere at the end of the sample draw probe.

Use of the hand-aspirated sample draw kits is covered in section 3.1.

Use of the motorized sample draw pump is covered in section 3.2.

A detailed description of the MultiVision probe assembly is given in section 5.7.

1.2 Multi-sensor capability

The MultiVision can be configured to simultaneously monitor oxygen, carbon monoxide, hydrogen sulfide and combustible gases and vapors. All sensors are replaceable in the field. The

MultiVision incorporates dedicated sensor channels, which eliminates the need for laborious reconfiguration procedures.

Note: It is necessary to verify the accuracy of the MultiVision by calibration with known concentration test gas whenever a change is made to the sensors installed in the instrument.

Calibration procedures are discussed in detail in Chapter 4.

The MultiVision uses electrochemical carbon monoxide and hydrogen sulfide sensors that have been designed to minimize the effects of common interfering gases. These sensors provide accurate, dependable readings for toxic gases commonly encountered during confined space entry and other industrial applications.

Different measurement units are used depending on the gas being measured.

Type of Hazard	Measurement unit
Oxygen (O ₂)	Percentage by volume
Combustible gas	Percentage of lower explosive limit (%LEL)
Carbon Monoxide, Hydrogen Sulfide	Parts per million (PPM)

Table 1.2 MultiVision Units of Measurement

1.3 Calibration

The MultiVision detector features fully automatic fresh air and span calibration.

⚠WARNING Accuracy of the MultiVision should be checked periodically with known concentration calibration gas. Failure to check accuracy can lead to inaccurate and potentially dangerous readings.

Calibration procedures are discussed in detail in Chapter 4

Recommended calibration frequency is discussed in Appendix B.

Use of these procedures is reserved for authorized personnel.

1.4 Alarm logic

MultiVision gas alarms can be adjusted with the MultiVision Programming Software Package. See the MultiVision Software Manual for details. Alarms may be set anywhere within the nominal range of the specific sensor type. When an

alarm set point is exceeded a loud audible alarm sounds, and the bright red LED alarm lights flash.

1.4.1 Atmospheric hazard alarms

⚠WARNING MultiVision portable gas detectors have been designed for the detection of deficiencies of oxygen, accumulations of flammable gases and vapors, and accumulations of specific toxic gases. An alarm condition indicating the presence of one or more of these potentially life-threatening hazards should be taken very seriously.

⚠WARNING In the event of an alarm condition it is important to follow established procedures. The safest course of action is to immediately leave the affected area, and to return only after further testing determines that the area is once again safe for entry. Failure to immediately leave the area may result in serious injury or death.

⚠WARNING A rapid up-scale reading followed by a declining or erratic reading may indicate a hazardous combustible gas concentration that exceeds the MultiVision's zero to 100 percent LEL detection range.

The combustible gas alarm is activated when the percent LEL (Lower Explosive Limit) gas concentration exceeds any pre-set alarm level.

Two oxygen alarm set points have been provided; a danger alarm for low concentrations associated with oxygen deficiency and a warning alarm for high concentrations associated with oxygen enrichment.

Four alarm set points have been provided for each toxic gas sensor: Warning, Danger, STEL and TWA (Time Weighted Average).

The STEL value displayed by the MultiVision represents the average concentration of readings for the target gas for the most recently completed 15 minutes of operation.

TWA values are calculated by taking the sum of readings for the target gas in the current operating session in terms of

parts-per-million-hours and dividing by an eight-hour period.

Sensor	Warning	Danger	STEL	TWA
CO	35	100	100	35
H ₂ S	10	20	15	10

MultiVision Default Toxic Sensor Alarm Levels

Appendix A discusses alarm levels and factory default alarm settings.

1.4.2 Low battery alarms

The MultiVision may be equipped with either rechargeable NiMH or alkaline battery packs. Alarms will be activated whenever battery voltage is too low to allow the safe operation of the instrument.

The MultiVision's initial low battery alarm occurs when battery voltage is reduced to 3.25 volts and is displayed as an empty battery cell on the right side of the display. Once the battery voltage reaches 3.0 volts, the MultiVision will automatically go into alarm, initiate the shut-down sequence and turn itself off.

For more information concerning the low battery alarms, see section 2.4.4.

⚠WARNING Use only Duracell MN1500 or Ultra MX1500, Eveready Energizer E91-LR6, Eveready EN91, Radio Shack 23-874* size AA 1.5V Alkaline batteries, Eveready CH15* or Radio Shack 23-149* size AA NiCad batteries, or Eveready L91*† AA 1.5V Lithium batteries. Substitution of batteries may impair intrinsic safety.

*Not for use with ATEX certified instruments. (ATEX is a European safety directive).

†Not CSA approved (CSA is the Canadian Standards Association (similar to UL in the United States)).

1.4.3 Sensor over range alarms.

The MultiVision will go into alarm if a sensor is exposed to a concentration of gas that exceeds its established range. In the case of an LEL reading that exceeds 100% LEL, the LEL channel will be automatically disabled by the instrument and the instrument will remain in constant alarm until it is turned off, brought to an area that is known to be safe, and then turned back on. The display will show "OL" in place of the sensor reading for any channel that has gone into over range alarm.

See section 2.4.5 for further details on sensor over range alarms.

A sensor range chart is provided in Appendix C.

⚠WARNING In the event of an LEL overrange alarm the MultiVision must be turned off, brought to an area that is known to be safe and then turned on again to reset the alarm.

1.4.4 LEL response failure due to lack of O₂ alarm

The MultiVision features automatic warning against LEL sensor response failure due to lack of oxygen. See section 2.4.6 for details.

1.4.5 Security Beep/Flash

The MultiVision includes a security beep function that is designed to notify the user that the instrument is powered up and running. Once enabled the MultiVision will emit a short audible beep and give a short flash on the LED at a user-defined interval. The security beep/flash function may be enabled and the interval may be changed with either the MultiVision software package or through the IQ System Interface.

1.4.6 Other alarms and special microprocessor features

MultiVision software includes a number of additional alarms designed to ensure the proper operation of the instrument. When the MultiVision detects that an electronic fault or failure condition has occurred, the proper audible and visible alarms are activated and an explanatory message or message code is displayed.

⚠WARNING The MultiVision is designed to detect potentially life threatening atmospheric conditions. Any alarm condition should be taken seriously. The safest course of action is to immediately leave the affected area, and return only after further testing determines that the area is once again safe for entry.

1.5 Other electronic safeguards

Several automatic programs prevent tampering and misuse of the MultiVision by unauthorized persons. Each time the detector is turned on, the MultiVision

automatically tests the LED alarm lights, audible alarm, internal memory and pump status. The battery is monitored continuously for proper voltage. The MultiVision also monitors the connection of sensors that are currently installed. The detection of any electronic faults causes the activation of the audible and visible alarms and causes the display of the appropriate explanatory message.

If the MultiVision detects an error in one of the sensors, the datalogger or in the instrument itself, it will display an error code as shown.

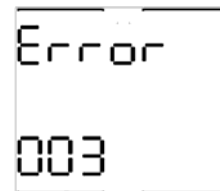

See section 2.5 for error code definitions.

1.6 Sensors

The MultiVision can be configured to simultaneously monitor oxygen, carbon monoxide, hydrogen sulfide and combustible gases and vapors. The sensor configuration of the MultiVision can be specified at the time of purchase, or changed in the field by appropriately trained personnel.

Replacement sensor part numbers and sensor ranges are given in Appendix B. Sensor cross-sensitivity figures are given in Appendix C.

⚠WARNING A sensor that cannot be calibrated or is found to be out of tolerance must be replaced immediately. An instrument that fails calibration may not be used until testing with known concentration test gas determines that accuracy has been restored, and the instrument is once again fit for use.

Calibration procedures are discussed in detail in Chapter 4.

1.7 Built-in sample draw pump

At time of purchase, a motorized sample-draw pump is available for the MultiVision for situations requiring continuous "hands free" remote monitoring.

The pump contains a pressure sensor that detects restrictions in airflow caused by water or other obstructions being drawn into the unit and immediately acts to turn the pump off in order to protect the

sensors, pump, and other MultiVision components from damage.

Pump status is continuously monitored by the MultiVision microprocessor. When the pump is active and functioning properly, "PUMP" is displayed near the center of the LCD display. Low flow or other pump fault conditions activate audible and visible alarms and cause the display of the appropriate explanatory message.

1.8 Black box data recorder

A black box data recorder is a standard feature in the MultiVision. The "black box" is continually in operation whether the user is aware of it or not. The black box stores important information such as gas readings, turn-on times, turn-off times, temperatures, battery conditions, the most recent calibration date and settings, types of sensors currently installed, sensor serial numbers, warranty expiration and service due dates, and current alarm settings.

There is a finite amount of memory storage available in the black box data recorder. Once the memory is "full", the MultiVision will begin to write the new data over the oldest data. The black box data recorder will store approximately 40 hours of data in one-minute increments. After 40 hours have passed, the MultiVision will begin to write new data over the oldest data. In this way, the newest data is always conserved.

If the MultiVision includes the Infrared upgrade, then the information in the "black box" can be downloaded through interface with either the IQ Controller or through IQ DataLink.

If the MultiVision does not include the Infrared upgrade, then the entire MultiVision instrument must be returned to Sperian Instrumentation for data extraction. Once the data is downloaded from the instrument, a report will be generated. The unit and the report will then be returned to the user. Simply call Sperian's Instrument Service Department to obtain a return authorization number. There is no charge for the downloading service, but the user is responsible for any freight charges incurred.

Note: MultiVision instruments must be returned to Sperian Instrumentation for the infrared upgrade. Call Sperian

Instrumentation's Technical Service Department for details.

1.9 MultiVision design components

1. **Case:** The instrument is enclosed in a metal plated ABS case. A rubber gasket between the upper and lower sections of the case protects against leakage or exposure to liquids.
2. **Front face:** The front face of the instrument houses the LCD (liquid crystal display), alarm light and audible alarm.
3. **Display:** A liquid crystal display (LCD) allows display of readings, messages, and other information.
4. **Alarm lights:** Two front-mounted LED (light emitting diode) alarm lights provides a visual indication of alarm state. The lights emit a bright red light when a sensor alarm level is exceeded.
5. **Infrared Port:** Units with the infrared upgrade will have the infrared port located on the front of the instrument. The infrared port is used for communications between the MultiVision and a PC.
6. **On / Off "MODE" button:** The large black push-button on the left side of the instrument is called the "MODE" button. The MODE button is used to turn the MultiVision on and off as well as to control most other operations, including the automatic calibration adjustment.
7. **Sensor compartment cover:** The sensors are located at the top of the instrument and are protected by a vented sensor compartment cover. A water-resistant gasket and inner-liner protect the instrument against leakage or exposure to liquids.
8. **Audible alarm port:** A cylindrical port extending through the front of the instrument just below the sensor compartment cover houses the loud audible alarm. The waterproof audible alarm seats directly to the rubber inner-liner to protect the instrument against leakage or exposure to liquids.
9. **Battery pack:** Two types of interchangeable battery packs (rechargeable NiMH and disposable alkaline) are available for use. NiMH battery packs may be recharged while

the pack is installed in the instrument, or removed from the instrument for separate recharging.

10. Battery charger connector: A water resistant connector at the bottom of the case assembly is used to connect the MultiVision to the “drop in” style charger.

11. Bottom surface: A sturdy clip allows the user to wear the MultiVision on a belt or other article of clothing.

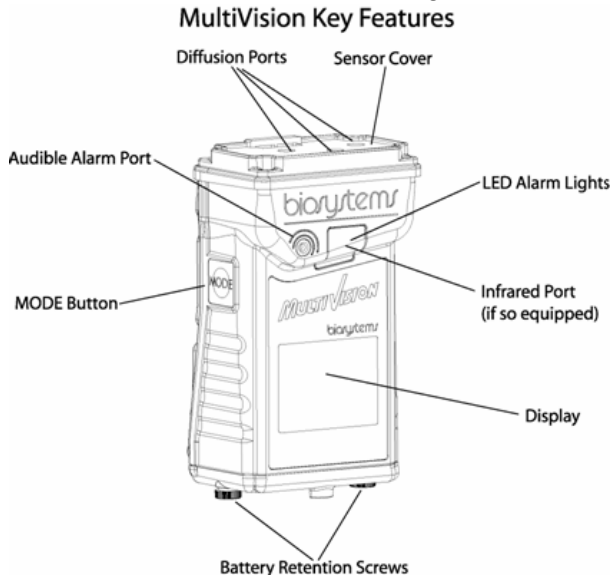

Figure 1.9 MultiVision Key Features

1.10 MultiVision standard accessories

Standard accessories included with every MultiVision include calibration adapter, additional tubing for use during calibration, reference manual and quick reference card.

The optional sample draw kit consists of a sample draw / calibration adapter, squeeze bulb, replacement sample probe filters, and ten feet of tubing. The sample probe is available separately.

Standard configurations of the MultiVision are delivered in a foam-lined box.

1.10.1 Alkaline MultiVision detectors

If the MultiVision has been purchased as an alkaline instrument, the standard accessories include an alkaline battery pack and a set of 3 disposable AA alkaline batteries.

1.10.2 NiMH MultiVision detectors

If the MultiVision has been purchased as a NiMH rechargeable instrument, the

standard accessories include NiMH battery pack and a slip in MultiVision charger.

1.11 MultiVision kits

MultiVision detectors may also be purchased as part of a complete kit that includes calibration gas, fixed-flow regulator and a hard-shell carrying case.

1.11.1 MultiVision Confined Space Kits

In addition to the standard accessories listed above, Confined Space Kits also include calibration fittings, fixed-flow regulator with pressure gauge, and appropriate large cylinder(s) of calibration gas in a foam-lined, waterproof hard-shell carrying case.

1.11.2 MultiVision Value Packs

MultiVision Value Packs include an alkaline MultiVision, all standard accessories, calibration fittings, small cylinder(s) of calibration gas, and fixed flow regulator in a foam-lined non-waterproof hard-shell carrying case.

2. Basic Operations

The MultiVision is a true one-button gas detector. The MODE button is located on the left side of the instrument and controls all field-level operations including the following

- Turning the MultiVision on and off
- Turning on the backlight
- Viewing the MAX reading screen
- Viewing the TWA screen
- Initiating the calibration sequence

2.1 Turning the MultiVision On

To turn the MultiVision on, press and hold the MODE button for one second. The first screen is the test screen for the LCD and all sections should be lit.

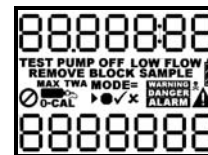

Note: The startup sequence takes approximately 50 seconds to complete. To reduce the time and number of screens in the startup sequence, press the MODE button once the instrument turns on.

The next screen shows the firmware version. “dL” will appear in the upper right for instruments with a fully enabled datalogger.

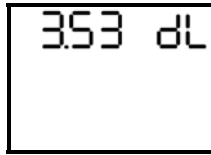

After the firmware version, MultiVision will briefly list the sensors that are currently recognized by the instrument.

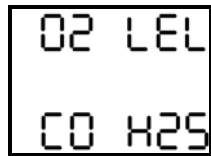

The serial number screen will be shown next.

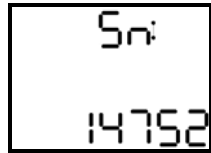

If the MultiVision is equipped with a fully enabled datalogger, then the following screen will be shown. The time figure in the upper right corner indicates the sampling interval in minutes and seconds.



The time will then be shown followed by the date:

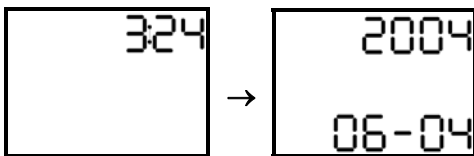

The instrument will display “Self Test” as it performs a few operational checks.

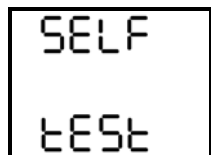

During the self test, the MultiVision tests for installed sensors, performs a system memory check and tests to see if a motorized pump is installed in the instrument. If the MultiVision contains an internal motorized sample pump, it will be briefly activated during the self test. For details on start up procedures for pump-

equipped MultiVision instruments see section 2.1.1 below.

The instrument temperature will then be shown.

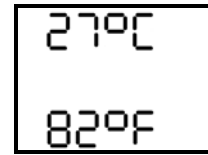

The warning alarm levels screen will then be shown followed by the danger, STEL and TWA alarm levels screens.

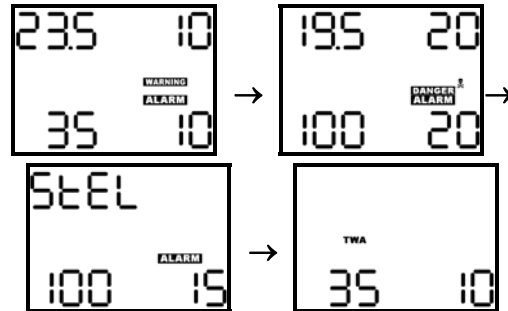

Following the danger alarm level screens, the calibration due screen will be shown with the number of days until the next calibration.



The MultiVision will then proceed to the current gas readings screen.



2.1.1 Start up with pump

MultiVision instruments that are equipped with a built-in motorized sample draw pump will have a slightly longer start up sequence. After the calibration due screen, the MultiVision will prompt you to leak test the pump.

Note: The sample probe assembly must be attached when the pump is started.

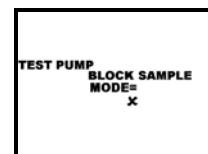

Block the sampling inlet by placing a finger over the end of the sample probe

assembly. Once the MultiVision recognizes that the sample has been blocked, it will instruct you to remove the blockage.



Once the blockage is removed, the MultiVision will proceed to the current gas readings screen.

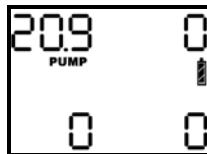

For information concerning proper attachment of the sample probe assembly to pump-equipped MultiVision instruments, see section 3.1.

2.2 Operating Logic

Once the MultiVision has completed the start up sequence, the current gas readings screen will be shown.

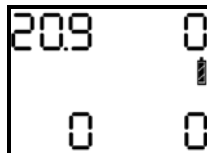

If a sensor is not detected in one of the sensor channels during start up, the reading in the designated sensor channel will show two dashes "--" instead of a readout. If a complete sensor failure occurs while the instrument is turned off, the instrument may operate as if the sensor is not present in the instrument. In the example at right, the LEL sensor has not been detected and a reading of "--" is shown. The MultiVision only detects those substances that have actual readings in the current gas readings screen during the current operating session.

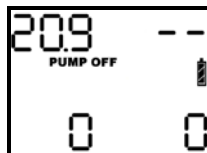

⚠WARNING: Always verify that all sensors present in the instrument are shown with an actual reading on the current gas readings screen whenever the MultiVision is turned on. Failure to verify sensor presence prior to use in a

hazardous location may result in serious injury or death.

For instruments with a pump, the pump status is shown as "PUMP" or "PUMP OFF".

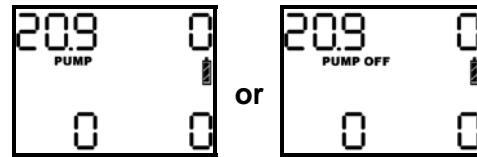

The battery icon at right gives an indication of how much power is left in the battery. The illustration below shows the stages of the battery from full to empty (left to right).

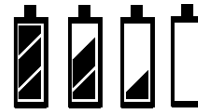

To turn on the backlight press the MODE button once.

To view the MAX readings screen, press the MODE button a second time.



Press the MODE button a third time to view the Time Weighted Averages (TWA) for the operating session.

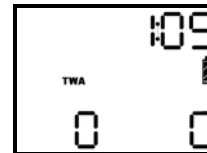

Note: The TWA screen will not be shown if the TWA screen has been disabled with the MultiVision software package. See the MultiVision Software Manual for details.

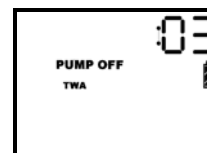

Note: The MultiVision must be in continuous operation for at least 15 minutes before it will be able to calculate the TWA values. For the first 15 minutes of any operating session, the screen will show the length of time that the instrument has been operating instead of the TWA values.

2.3 Turning the MultiVision Off

To turn the MultiVision off, press and hold the MODE button until the display reads "Release Button".

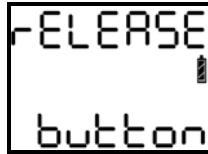

Once the MODE button is released, the MultiVision display will briefly show OFF and then go blank.



2.4 Alarms

The MultiVision is configured with a series of alarms that are designed to warn the user of dangerous conditions.

⚠WARNING The MultiVision is designed to detect potentially life threatening atmospheric conditions. Any alarm condition should be taken seriously. The safest course of action is to immediately leave the affected area, and return only after further testing determines that the area is once again safe for entry.

2.4.1 Warning Alarms

Warning alarms indicate a dangerous atmospheric condition that has not yet risen to the level necessary to initiate the danger alarms. Warning alarm levels are shown during the start up sequence.

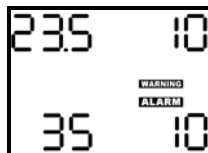

Warning alarms can be temporarily silenced by pressing the MODE button if this option is enabled with BioTrak in datalogger-equipped models.

2.4.2 Danger Alarms

Danger alarms indicate a significantly hazardous condition and are also shown in the start up sequence.



2.4.3 TWA Alarms

TWA alarms only apply to toxic sensor channels. TWA values are calculated by taking the sum of exposure to a particular toxic gas in the current operating session in terms of parts-per-million-hours and dividing by an eight-hour period. The default TWA alarm level for the MultiVision CO sensor is 35PPM. The default TWA value for the MultiVision H₂S sensor is 10PPM.

2.4.4 Low battery alarms

Whenever battery voltage is reduced to approximately 3.25 volts, the battery icon on the LCD will appear empty, which means that a low battery condition exists.



If the battery icon is empty, leave the area immediately. If the MultiVision is equipped with an alkaline battery pack, proceed to an area that is known to be safe area (containing 20.9% oxygen, 0% LEL and 0 PPM toxic gases) and change the batteries. If the MultiVision is equipped with a NiMH battery pack, proceed to an area that is known to be safe and recharge the battery pack.

When battery voltage reaches approximately 3.0 volts, the MultiVision is no longer safe to use with the current battery pack. The screen will briefly display a "0-BAT" warning and give a ten-second countdown. At the end of the countdown, the MultiVision will turn itself off.

⚠WARNING The MultiVision must be located in a non-hazardous location during the charging cycle. Charging the MultiVision in a hazardous location may impair intrinsic safety.

⚠WARNING The MultiVision must be located in a non-hazardous location whenever alkaline batteries are removed from the alkaline battery pack. Removal of the alkaline batteries from the battery pack in a

hazardous area may impair intrinsic safety.

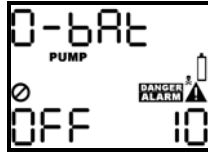

CAUTION: Always turn the MultiVision off prior to removing the battery pack. Removal of the battery pack with the instrument turned on may cause corruption of stored data in the MultiVision.

2.4.5 Sensor over range alarms

The MultiVision will go into alarm if a sensor is exposed to a concentration of gas that exceeds its established range. In the case of an LEL reading that exceeds 100% LEL, the LEL channel will be automatically disabled by the instrument and the alarm will latch (remain on) until the instrument is turned off. The MultiVision must be turned off, brought to an area that is known to be safe (containing 20.9% oxygen, 0% LEL and 0 PPM toxic gases), and then turned back on. The display will show “OL” in place of the sensor reading for any channel that has gone into over range alarm.

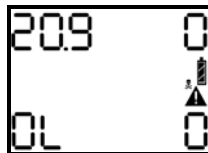

⚠WARNING In the event of an LEL overrange alarm the MultiVision must be turned off, brought to an area that is known to be safe (containing 20.9% oxygen, 0% LEL and 0 PPM toxic gases), and then turned on again to reset the alarm.

2.4.6 LEL failure due to lack of oxygen alarm

The LEL sensor in the MultiVision requires a certain amount of oxygen to function properly. When oxygen levels fall below 11% by volume, the MultiVision will show “---” in place of the LEL reading.

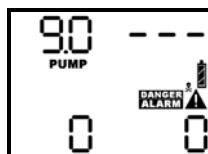

2.5 PC connection via infrared port

MultiVision instruments that are equipped with a fully enabled datalogger can be downloaded to a PC using Sperian’s BioTrak or IQ software through the MultiVision’s infrared port. For the location of the infrared port, see figure 1.9 above.

1. With the MultiVision turned off, hold the MODE button down until four beeps are heard. Depending on the software version, this will normally take between 10 and 20 seconds. The following screen will be shown once the infrared port has been activated.



2. Align the infrared port on the MultiVision with the PC’s infrared port to complete the connection.

Note: For further instructions concerning the download procedure for the MultiVision, see the BioTrak or IQ System manual as appropriate.

2.5 Error Messages

The MultiVision microprocessor monitors the instrument continuously. When a problem is found the instrument will show an error message.

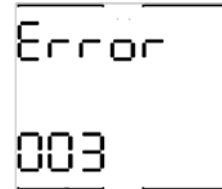

MultiVision Error Messages	
UNIT_MEMORY	3
O2_MEMORY	4
LEL_MEMORY	5
CO_MEMORY	6
H2S_MEMORY	7
DATALOGGER_CRC	8
NO_SENSORS	10

If an error message is shown, stop using the detector and contact Sperian Instrumentation or you local distributor for further information.

3. Sampling

The MultiVision may be used in either diffusion or sample-draw mode. In either mode, the gas sample must reach the sensors for the instrument to register a

gas reading. The sensors are located near the top of the instrument underneath the sensor compartment cover plate.

In diffusion mode, the atmosphere being measured reaches the sensors by diffusing through vents in the sensor compartment cover plate. Normal air movements are enough to carry the sample to the sensors. The sensors react quickly to changes in the concentrations of the gases being measured. Diffusion-style operation monitors only the atmosphere that immediately surrounds the detector.

The MultiVision can also be used to sample remote locations with either the optional hand-aspirated sample-draw kit, or with the optional built-in, motorized sample draw pump. During remote sampling, the gas sample is drawn into the sensor compartment through the probe assembly and a length of tubing.

3.1 Manual sample draw kit

A manual sample draw kit is available as an accessory for the MultiVision. The manual sample draw kit is comprised of a sample draw probe, 2 sections of tubing, a squeeze bulb and an adapter that is used to connect the sample draw accessories system to the MultiVision.

To ensure accurate readings while using the manual sample draw kit, it is necessary to squeeze the bulb once for every one foot of sampling hose for the sample to first reach the sensors, and then to continue squeezing the bulb once per second for an additional 45 seconds or until readings stabilize.

3.1.1 Manual sample draw kit usage

To attach the manual sample draw kit to the MultiVision:

1. Connect the short section of hose that comes off of the squeeze bulb to the sample draw adapter. With the knurled screw at the front, the hose should be attached to the inlet on the left side of the adapter. Then

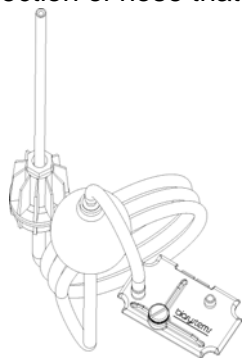

connect the other end of the hose to the sample probe as shown.

2. To test the seals in the sample draw system, cover the end of the sample draw probe with a finger, and squeeze the aspirator bulb. If there are no leaks in the sample draw kit components, the bulb should stay deflated for a few seconds.

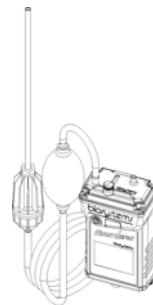

3. Secure the calibration adapter (with the sample draw assembly attached) to the MultiVision by inserting the tab and tightening the knurled screw at the top of the adapter.

The correctly assembled manual sample draw assembly is shown at left.

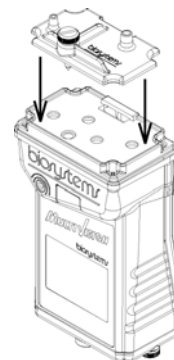

4. Insert the end of the sample probe into the location to be sampled.
5. Squeeze the aspirator bulb several times to draw the sample from the remote location to the sensor compartment. See section 3.1 for further information on obtaining accurate readings with the manual sample draw kit.
6. Note the gas measurement readings.

CAUTION: Hand aspirated remote sampling only provides continuous gas readings for the area in which the probe is located while the bulb is being continuously squeezed. Each time a reading is desired, it is necessary to squeeze the bulb a sufficient number of times to bring a fresh sample to the sensor compartment.

3.2 Motorized sample draw pump

At the time of purchase, a built-in, motorized sample-draw pump is available for the MultiVision for situations requiring continuous "hands free" remote monitoring. Use of the motorized sample draw pump allows the MultiVision to continuously monitor remote locations. The pump is powered by the MultiVision battery. MultiVision instruments

configured with a pump will always display the status of the pump in the current gas readings screen as either “PUMP” or “PUMP OFF”.

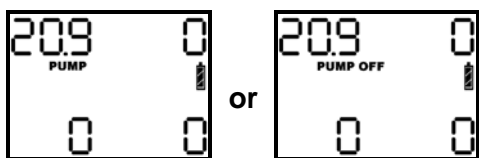

To ensure accurate readings while using the continuous sample pump, it is necessary to allow the pump to draw the sample for one second for every one foot of sampling hose plus an additional 45 seconds or until readings stabilize. For example, with 10' of tubing, it will be necessary to allow a minimum of 55 seconds for the sample to be drawn into the sensor chamber and for the readings to stabilize.

MultiVision instruments configured with the built-in, motorized pump automatically recognize when the pump adapter is attached to the instrument. If the pump adapter is attached when the MultiVision is turned off, the instrument will automatically initiate the pump start up sequence when the instrument is turned on. If the pump is attached during instrument operation, the instrument will automatically initiate the pump test sequence before returning to the current gas readings screen.

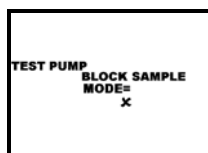

Block the pump inlet by placing a finger over the end of the sample probe assembly. Once the MultiVision recognizes that the sample has been blocked, it will instruct you to remove the blockage.

If the pump adapter is removed, the instrument will return to the current gas readings screen in diffusion mode. Pressing MODE at the prompt will cause the instrument to shut down.

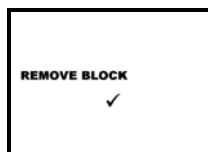

Once the blockage is removed, the MultiVision will proceed to the current gas readings screen.

3.2.1 Starting the motorized sample pump

The pump adapter contains a magnet that activates an electronic switch that turns on the pump.

First attach the probe and tubing to the calibration adapter as shown. With the knurled screw at the front, the hose should be attached to the inlet on the left side of the adapter.

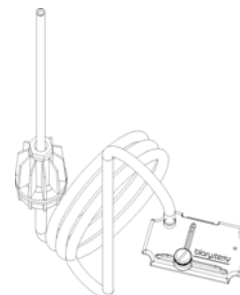

Secure the calibration adapter (with the sample draw assembly attached) to the MultiVision by inserting the tab and tightening the knurled screw at the top of the adapter. The correctly assembled sample draw assembly for pump-equipped MultiVision instruments is shown at left.

See section 3.2 for further information on obtaining accurate readings with the continuous sample pump.

3.2.2 Turning off the pump

To turn off the pump remove the pump adapter from the top of the instrument. The MultiVision will immediately go into alarm and the following screen will be shown.

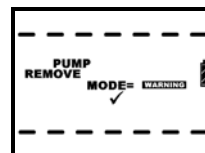

Press the MODE button to return to diffusion operation. PUMP OFF will then be shown on the current gas readings screen.

3.2.2 Low flow alarm

MultiVision instruments configured with a pump contain a pressure sensor that detects restrictions in airflow caused by water or other fluids being drawn into the

unit and immediately acts to turn the pump off in order to protect the sensors, pump, and other MultiVision components from damage.

Pump status is continuously monitored by the MultiVision microprocessor. When the pump is active and functioning properly, "PUMP" is displayed near the center of the LCD display. Low flow or other pump fault conditions activate audible and visible alarms and cause the display of the appropriate explanatory message.

CAUTION: Never perform remote sampling with the MultiVision without the sample probe assembly. The sample probe handle contains replaceable filters designed to block moisture and remove particulate contaminants. If the pump is operated without the probe assembly in place, contaminants may cause damage to the pump, sensors and internal components of the MultiVision

The sample draw pump includes a pressure sensor designed to protect the MultiVision from exposure to water or other liquids. If there is a change in pressure in the sample draw assembly due to fluid intake or other blockage, the pump immediately shuts down. After a few seconds audible and visible alarms indicating a low flow condition will also be activated.

CAUTION: Insertion of the sample draw tube into a fluid horizontally or at a low angle may lead to water ingress and may cause damage to the sensors and internal components of the MultiVision.

The pressure sensor in the sample draw pump is designed to detect pressure changes while the sample-draw probe is being held in a vertical position. If the probe is held horizontally or at a low angle while inserted into a fluid, a pressure drop sufficient to cause the pump to shut down may not be generated, and water could be drawn into the pump assembly causing damage to the pump, sensors and internal components of the MultiVision.

To avoid potential damage, care must be taken to keep the probe vertical whenever fluids may be present.

If the MultiVision determines that a significant pressure change has occurred, it will go into alarm and the following screen will be shown:

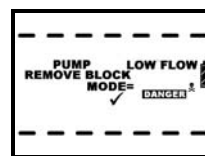

Remove the blockage and press the MODE button to acknowledge the alarm and resume sampling.

3.3 Sample draw probe

The MultiVision's sample draw probe is the standard probe assembly from Sperian Instrumentation. The illustration in chapter 5 gives a breakdown of all parts in the sample draw probe with part numbers.

The sample probe handle contains moisture barrier and particulate filters designed to remove contaminants that might otherwise harm the instrument.

CAUTION: Never perform remote sampling without the sample probe and hose assembly. The sample probe handle contains replaceable filters designed to block moisture and remove particulate contaminants. If the pump is operated without the probe assembly in place, contaminants may cause damage to the pump, sensors and internal components of the MultiVision.

Particulate contaminants are removed by means of a cellulose filter. The hydrophobic filter includes a Teflon™ barrier which blocks the flow of moisture as well as any remaining particulate contaminants.

Sample probe filters should be replaced whenever visibly discolored due to contamination. See section 5.7.1 for a list of available sample probe filter replacement kits.

4. Calibration

The accuracy of the MultiVision should be verified on a regular basis. Verification can be as simple as performing a bump test, which is described below in section 4.1.

If exposure to fresh air yields an oxygen reading of less than 20.7% or greater than 21.1% or a toxic or LEL sensor reading of anything other than 0, then a Fresh Air/Zero Calibration should be performed as described in section 4.2.

If exposure to a known concentration calibration gas (as described in section 4.1) shows that LEL or toxic sensor readings are not between 90% and 120% of the value given on the calibration gas cylinder, then the Span Calibration should be performed as described in section 4.3.

See Appendix B for Sperian Instrumentation's official recommendations concerning calibration frequency.

4.1 Functional (Bump) testing

The accuracy of the MultiVision may be verified at any time by a simple functional (bump) test.

To perform a functional (bump) test, do the following:

1. Turn the MultiVision on and wait at least three minutes to allow the readings to fully stabilize. If any of the sensors have just been replaced, the new sensor(s) must be allowed to stabilize prior to use. See section 5.6 for further details on sensor stabilization requirements.
2. Make sure the instrument is located in fresh air.
3. Verify that the current gas readings match the concentrations present in fresh air. The oxygen (O₂) sensor should read 20.9% (+/-0.2%/vol.). The readings for the LEL sensor should be 0% LEL and toxic sensors should read 0 parts-per-million (PPM) in fresh air. If the readings deviate from the expected levels in a fresh air environment, proceed to section 4.2 and perform the fresh air calibration adjustment then proceed to step 4 below.
4. Attach the calibration adapter and connect the calibration cylinder to the MultiVision as shown in figure 4.1. Flow gas to the sensors.
5. Wait for the readings to stabilize. (Forty-five seconds to one minute is usually sufficient.)



Figure 4.1 Bump Test and Span Calibration set up

6. Note the readings. Toxic and LEL sensor readings are considered accurate in a bump test if they are between 90% and 120% of the expected reading as given on the calibration cylinder. If the readings are considered accurate, then the instrument may be used without further adjustment. If toxic and LEL the readings do not fall within 90% and 120% of the expected reading as given on the calibration cylinder, then readings are considered inaccurate. If readings are considered inaccurate, proceed to section 4.3 and perform the span calibration.

Sperian's multi-calibration gas mixtures contain approximately 18% oxygen. During the bump test the oxygen sensor should read within +/- 0.5% of the level given on the calibration cylinder.

4.2 Fresh Air/Zero Calibration

⚠WARNING Fresh air/zero calibrations may only be performed in an atmosphere that is known to contain 20.9% oxygen, 0.0% LEL and 0 PPM toxic gas.

Note: For instructions on performing the fresh air/zero calibration in a contaminated atmosphere, proceed to section 4.4.

To initiate the fresh air/zero calibration:

1. Press the MODE button three times within two seconds to begin the fresh air/zero calibration sequence. The MultiVision will briefly display 0-CAL and then begin a 5-second countdown.



2. Press the MODE button before the end of the 5-second countdown to begin the fresh air/zero calibration. The fresh air/zero calibration is initiated when the MultiVision alternates between the following two screens:

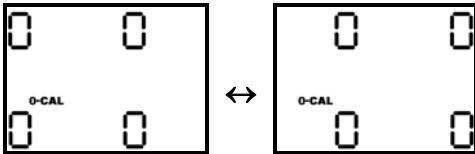

3. The fresh air/zero calibration is complete when the instrument begins another 5-second countdown for the span calibration. If span calibration is not required, allow the countdown to reach 0 without pressing the MODE button.

4.2.1 Fresh air calibration failure

In the event of a fresh air calibration failure, the alarms will be activated and the instrument will display the following screen three times intermittently with the current gas readings screen.

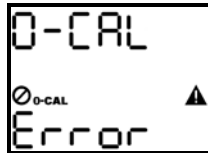

After the third display of the 0-CAL Error screen, the instrument will return to the current gas readings screen and the visual and audible alarms will cease. The warning symbol and smaller 0-CAL message will be shown intermittently in the current gas readings screen until a successful fresh air calibration is performed.

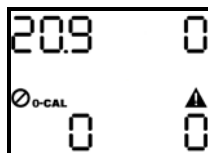

If a successful fresh air / zero calibration is not performed prior to instrument shut down, the O₂ sensor will be identified as needing calibration during instrument start up.

Possible causes and solutions

1. The atmosphere in which the instrument is located is contaminated (or was contaminated at the time the instrument was last fresh air calibrated).
2. A new sensor has just been installed.
3. Instrument has been dropped or banged since last turned on.
4. There has been a significant change in temperature since the instrument was last used.

Recommended action:

Take the instrument to fresh air and allow readings to stabilize. Perform the fresh air/zero adjustment again. If the manual fresh air/zero procedure fails to correct the problem, perform the manual fresh air / zero calibration procedure as described in section 4.2.2 below.

4.2.2 Manual fresh air / zero calibration

The MultiVision includes safeguards to prevent fresh air calibration in contaminated environments. If the standard fresh air / zero calibration fails a second time, the instrument may be “forced” to accept the fresh air calibration by performing the manual fresh air / zero calibration.

⚠WARNING Fresh air/zero calibrations may only be performed in an atmosphere that is known to contain 20.9% oxygen, 0.0% LEL and 0 PPM toxic gas.

1. Initiate the standard fresh air / zero calibration sequence by pressing the MODE button three times in rapid succession.



2. Press the MODE button before the end of the 5-second countdown and **continue to hold the MODE button.** As in the standard fresh air /zero

calibration, the MultiVision will alternate between the following two screens:

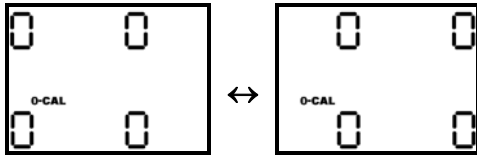

- The fresh air/zero calibration is complete when the instrument begins another 5-second countdown for the span calibration. If span calibration is not required, allow the countdown to reach 0 without pressing the MODE button.

If the MultiVision still fails to calibrate after attempting the manual fresh air / zero calibration, call Sperian Instrumentation. Sperian Instrumentation's telephone number is shown on the front of this manual.

4.3 Span Calibration

Once the fresh air / zero calibration has been successfully completed, the MultiVision will automatically proceed to the automatic span calibration countdown screen. The instrument is ready for span calibration when the following screen is shown.



Press the MODE button before the countdown is complete to initiate the span calibration. The screen will immediately show "APPLY GAS" and then list the sensors for calibration.

Note: Sperian Instrumentation recommends the use of multi-component calibration gas for calibrating the MultiVision.

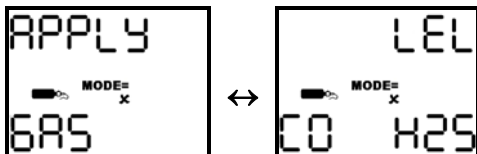

Apply calibration gas as shown above in figure 4.1. The readout will change to a numerical display almost immediately and will alternate with the sensor screen.

The actual calibration of the oxygen sensor to 20.9% occurs during the fresh air calibration, but the oxygen sensor is

tested for response to diminished oxygen levels during span calibration. Sperian calibration gas cylinders contain approximately 18.0% oxygen. In order to pass the span calibration, the MultiVision must register an oxygen reading below 19.5% during span calibration.

See section 4.3.2 below if the oxygen sensor does not detect the drop in oxygen level and fails the span calibration.

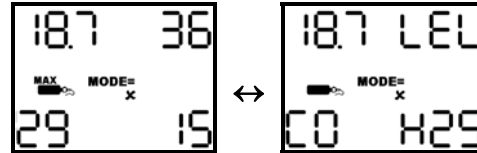

The calibration is fully automatic from this point on. Upon successful calibration of a sensor, the MultiVision will beep, show the adjusted reading for the calibrated sensors and then move on to the next sensor.



Once the calibration of all sensors is successfully completed, the MultiVision will briefly show the lowest oxygen reading obtained during the span calibration along with the maximum adjustment values for the LEL and toxic sensors.



The maximum adjustment values for the LEL and toxic sensors give an indication of the remaining sensitivity of the sensors. As sensitivity decreases, the maximum possible adjustment will decrease to approach the expected concentration of the calibration gas.

Note: Once the calibration cycle is successfully completed, the MultiVision will automatically turn itself off. Disconnect the calibration assembly prior to turning the instrument back on.

4.3.1 Span calibration failure: toxic and LEL sensors

When span calibration is due, the MultiVision's display will intermittently

show the warning symbol with the calibration bottle in the current gas readings screen.

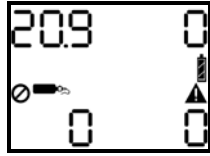

The MultiVision will also display a “Needs Cal” message for any sensors that are currently due for calibration during instrument start-up.

Possible causes and remedies:

1. Empty calibration gas cylinder. Verify that there is calibration gas in the cylinder.
2. Expired calibration gas cylinder. Verify that the expiration date on the cylinder has not passed.
3. Calibration gas setting does not correspond to calibration gas concentration. The default calibration gas settings are 50% LEL, 50PPM CO and 25PPM H₂S. If the values on the calibration cylinder are different from these values, the MultiVision’s calibration gas settings must be changed to match the new values. Changing the calibration gas settings requires the use of the MultiVision programming software, which is available separately.
4. LEL only: Type of calibration gas (standard) has changed significantly. LEL calibration gas may be based on several different response standards. Methane, propane and pentane are the most common. If using a new cylinder of calibration gas, make sure that the type and amount of combustible gas is identical to that of the previous bottle. Sperian offers calibration gases in Methane, Propane Equivalent and Pentane Equivalent.
5. Dead sensor. Replace sensor.
6. Instrument problem. Return the instrument to Sperian Instrumentation. Call the phone number on the front of this manual.

4.3.2 Span calibration failure: oxygen sensors

Sperian multi calibration gas cylinders contains approximately 18.0% oxygen. The reduced oxygen level in the

calibration gas cylinder allows the oxygen sensor’s response to be tested in the same manner as the toxic and LEL sensors.

If the O₂ sensor fails to register a reading below 19.5% during the span calibration, the following two screens will be shown immediately following the calibration attempt.

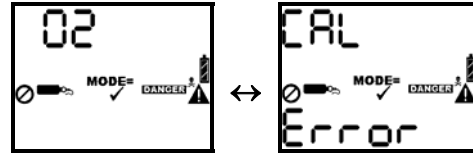

Press MODE to acknowledge the warning and turn the instrument off.

If the oxygen sensor fails to register the drop in oxygen during the span calibration while being challenged with calibration gas containing less than 19.0% oxygen, it should be considered out of tolerance and retired from service immediately.

⚠️WARNING A sensor that cannot be calibrated or is found to be out of tolerance should be replaced immediately. An instrument that fails calibration may not be used until testing with known concentration test gas determines that accuracy has been restored, and the instrument is once again fit for use.

Possible causes and remedies:

1. Calibration gas cylinder does not contain a reduced level of oxygen. Verify that the cylinder contains less than 19.0% oxygen.
To challenge the oxygen sensor without calibration gas, hold you breath of about 10 seconds (or more), and then **slowly** exhale directly onto the face of the sensor (in the same way you would attempt to fog up a piece of glass). If the descending oxygen alarm is set to 19.5%, the instrument should go into alarm after a few seconds.
- Note: See the diagram in section 5.6 for the location of the oxygen sensor.**
2. Oxygen sensor has just been replaced and has not had time to stabilize.
 3. Oxygen sensor failure.

4.4 How to calibrate the MultiVision in contaminated air

Calibration of the MultiVision is a two-step process. The first step is to expose the sensors to contaminate-free air with an oxygen concentration of 20.9% and 0 PPM toxic gases and perform a fresh air calibration.

Unfortunately, there are some locations that are never completely free of contaminants. An example would be a furnace intensive area that always has a background concentration of a few PPM CO. To fresh air / zero calibrate in a contaminated atmosphere, it is necessary to use special calibration cylinder containing "Zero Air". This gas cylinder, Sperian part number 54-9039, is used in conjunction with the sample draw calibration adapter.

Connect the "Zero Air" cylinder to the MultiVision using a length of tubing and the calibration adapter and flow the "Zero Air" gas across the sensors for a minute, just as if you were doing a span calibration. Then initiate the fresh air/zero calibration and proceed as described in 4.2 above. Once the fresh air/zero calibration has been completed using the "Zero Air" cylinder, disconnect the cylinder from the MultiVision and proceed to the span calibration with a second cylinder of calibration gas (if required).

5. Basic Maintenance

⚠WARNING To prevent ignition of flammable or combustible atmospheres, disconnect power before servicing any parts in the MultiVision.

5.1 Cleaning

The exterior surfaces of the MultiVision may be cleaned using a damp cloth only. Do not use cleaning agents of any kind. The introduction of cleaning agents to the detector may affect instrument functionality.

5.2 Storage

MultiVision detectors may be stored for long periods in a fresh air environment at temperatures between 10°C/50°F and 30°C/86°F.

See section 5.5.1 for specific instructions concerning the storage of rechargeable / NiMH versions of the MultiPro.

5.3 Batteries

The MultiVision is powered by interchangeable alkaline and NiMH rechargeable battery packs.

To remove the battery pack from the MultiVision, loosen the two knurled screws at the bottom of the instrument and slide the battery pack out of the instrument.

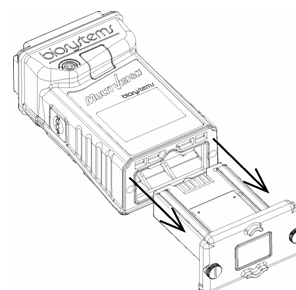

CAUTION Always turn the MultiVision off prior to removing the battery pack. Removal of the battery pack with the instrument turned on may cause corruption of stored data in the MultiVision.

Note: To ensure maximum water resistance, tighten both battery pack thumbscrews to finger tight and then an additional 1 turn. Over tightening may result in damage to the instrument.

5.4 Replacing alkaline batteries

The alkaline battery pack contains three AA alkaline batteries.

⚠WARNING The MultiVision must be located in a non-hazardous location whenever alkaline batteries are removed from the alkaline battery pack. Removal of the alkaline batteries from the battery pack in a hazardous area may impair intrinsic safety.

⚠WARNING Use only Duracell MN1500 or Ultra MX1500, Eveready Energizer E91-LR6, Eveready EN91, Radio Shack 23-874* size AA 1.5V Alkaline batteries, Eveready CH15* or Radio Shack 23-149* size AA NiCad batteries, or Eveready L91*† AA 1.5V Lithium batteries. Substitution of batteries may impair intrinsic safety.

*Not for use with ATEX certified instruments. (ATEX is a European safety directive).

†Not CSA approved (CSA is the Canadian Standards Association (similar to UL in the United States)).

To replace the alkaline batteries:

1. Remove the battery pack from the MultiVision as discussed in above in section 5.3.



2. Loosen the single screw at the end of the battery pack and remove the battery cover plate.

3. Remove the three alkaline batteries and replace them. Be sure to align the positive and negative ends in accordance with the diagram under each battery.

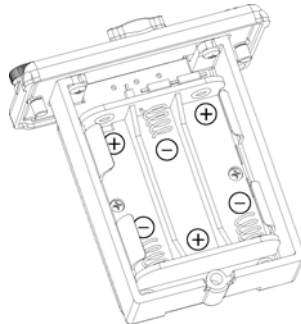

4. Reinstall the battery cover plate that was removed in step 2.
5. Return the battery pack to the MultiVision and re-tighten the two knurled screws. The MultiVision will automatically turn itself on upon battery insertion.

5.5 Maintaining NiMH battery packs

The MultiVision may be equipped with a rechargeable NiMH (nickel metal hydride) battery pack.

5.5.1 Storage guidelines for the NiMH battery

Never store NiMH-version MultiVision instruments at temperatures above 30 degrees Celsius (86 degrees Fahrenheit). Nickel Metal Hydride batteries may suffer deterioration resulting in damage to the internal components when stored at high temperatures. The battery may be irretrievably damaged resulting in reduced battery capacity and voltage.

Sperian Instrumentation recommends leaving MultiVision instruments with NiMH rechargeable batteries on the charger when not in use.

5.5.2 Charging guidelines for NiMH battery

The NiMH battery in the MultiVision should never be charged at temperatures lower than 5 degrees Celsius (40 degrees Fahrenheit) or higher than 30 degrees Celsius (86 degrees Fahrenheit). Charging at temperature extremes can permanently damage the MultiVision NiMH battery.

⚠WARNING The MultiVision must be located in a non-hazardous location during the charging cycle. Charging the MultiVision in a hazardous location may impair intrinsic safety.

5.5.3 Charging procedure for NiMH battery

1. Verify that the instrument is turned off. (If it is not, press the MODE button for three seconds until the message "Release Button" appears.)

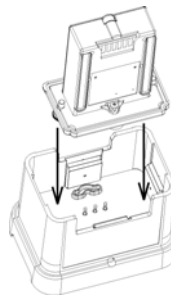

2. Plug the power supply in. The LED on the charger will show 2 or 3 long blinks during the diagnostic check and then show a short blink every five seconds to show that it is plugged in and operational.

3. Insert the MultiVision into the charging cradle. The LED on the charger will blink approximately once per second during the charging cycle.

The battery may also be charged outside of the instrument. First remove the battery as discussed in section 5.3. Then insert the battery alone into the charger as shown.

4. Charging is complete when the LED on the charger stops blinking.

CAUTION To achieve optimal charge and ensure long battery life of the NiMH battery, make sure that charging takes place in an area where the ambient air temperature is between 40 and 86 degrees Fahrenheit (5 and 30 degrees Celsius). Charging the battery in

temperatures above or below this range can damage the battery and will drastically affect battery life.

5.6 Sensor installation

The sensors in the MultiVision are housed at the top of the instrument.

To install a sensor:

1. Remove the sensor cover plate by removing the four screws at the top of the instrument.
2. The sensors are located under the sensor cover plate. Sensor channels in the MultiVision are specific to the type of sensor that occupies the channel. From left to right while looking at the front of the display, the sensors are as follows:

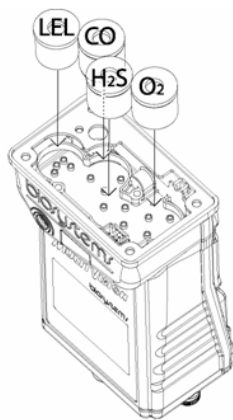
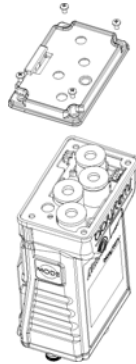

Combustible (LEL), CO, H₂S, O₂. See illustration.

3. Gently remove the sensor that is to be replaced.
4. Insert the new sensor into the appropriate location on the sensor interface board. See diagram at left.

5. New sensors must be allowed to stabilize prior to use according to the following schedule. The detector must be powered off and a functional battery pack must be installed for the sensor to stabilize.

Sensor	Stabilization Period
Oxygen (O ₂)	1 hour
LEL	none
CO	15 minutes
H ₂ S	15 minutes

6. Reinstall the sensor cover plate and tighten down the four screws.
7. If an oxygen sensor was replaced, perform the Fresh Air/Zero calibration as discussed in section 4.2.
8. If a combustible (LEL) or a toxic sensor has been replaced, wait approximately 3 minutes for the sensors to warm up and for the readings to stabilize. Then perform

both the Fresh Air/Zero calibration and the Span calibration as discussed in sections 4.2 and 4.3.

Note: Sensor channels in the MultiVision are specific to the type of sensor that occupies the channel. Be careful not to exchange the positions of the CO and H₂S sensors. Follow the diagram above when replacing the sensors.

5.7 Sample probe assembly

The MultiVision's sample draw probe is the standard probe assembly from Sperian Instrumentation. The illustration below gives a breakdown of all parts in the sample draw probe with part numbers.

The sample probe handle contains moisture barrier and particulate filters designed to remove contaminants that might otherwise harm the instrument.

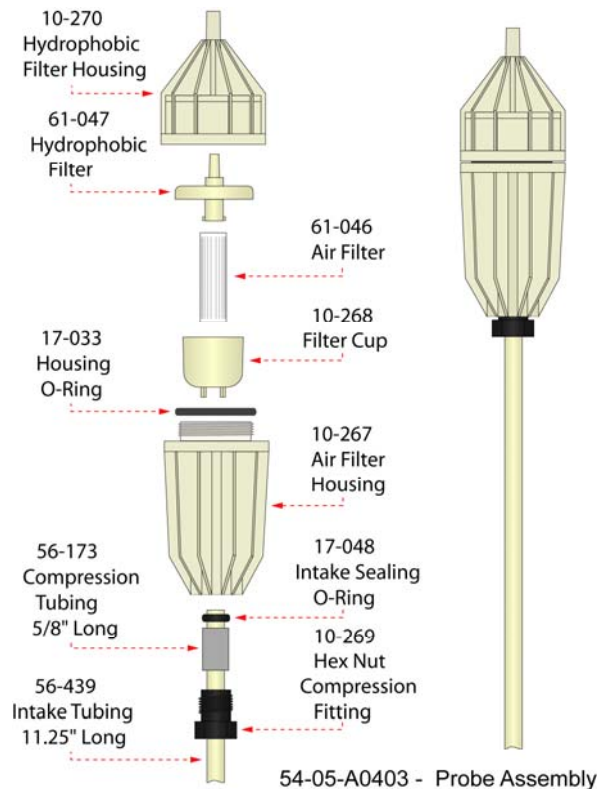

CAUTION: Never perform remote sampling without the sample probe and hose assembly. The sample probe handle contains replaceable filters designed to block moisture and remove particulate contaminants. If the pump is operated without the probe assembly in place, contaminants may cause damage to the pump, sensors and

internal components of the MultiVision.

Particulate contaminants are removed by means of a cellulose filter. The hydrophobic filter includes a Teflon™ barrier which blocks the flow of moisture as well as any remaining particulate contaminants.

Sample probe filters should be replaced whenever visibly discolored due to contamination.

5.7.1 Changing sample probe filters

The threaded sample probe handle is to provide access to the filters. The particulate filter is held in place by means of a clear filter cup. To replace the particulate filter, remove the old filter and cup, insert a new filter into the cup, and slide the cup back into place in the probe handle. The hydrophobic barrier filter fits into a socket in the rear section of the probe handle. (The narrow end of the hydrophobic barrier filter is inserted towards the rear of the handle.)

To avoid accidentally introducing particulate contaminants into the system, turn the sample probe upside-down prior to removing either the hydrophobic filter or the particulate filter.

The following replacement filter kits are currently available from Sperian Instrumentation:

Part No.	Kit	#Particulate	#Hydrophobic
54-05-K0401	Standard	10	3
54-05-K0402	Economy	10	0
54-05-K0403	Economy	30	10
54-05-K0404	Bulk	0	25
54-05-K0405	Bulk	100	0

5.7.2 Changing sample probe tubes (wands)

The standard 11.5" long butyrate probe tube is held in place by means of a hex-nut compression fitting and compression sleeve. The standard probe tube is designed to be easily interchangeable with other custom length sections of 1/4" OD tubing, or probe tubes made of other materials (such as stainless steel).

Probe tubes are exchanged by loosening the hex-nut compression fitting, removing the old tube, sliding the compression sleeve into place around the new tube, inserting the new tube into the probe handle, then replacing and tightening the hex-nut.

Note: The sample probe must be checked for leakage (as discussed in Section 3.1.1) whenever filters or probe tubes are exchanged or replaced before being returned to service.

5.8 Exploded view and replacement parts list

1. 54-41-001 Calibration adapter
2. 54-41-003 Pump adapter
3. 05-1147 Sensor cover screw (4)
4. 10-438 Diffusion sensor cover
5. 34-072 Sensor cover gasket
6. 05-1147 Sensor interface board screw (2)
7. 10-434 Main housing
8. 31-303 MODE keypad membrane
9. 35-0470 Main housing gasket
10. 35-0488 Alkaline battery pack
11. 35-0489 NiMH battery pack
12. 35-0487 Sensor board assembly (unit w/o pump)
13. 35-0492 Sensor interface board (unit w/ pump)
14. 35-0490 Pump assembly
15. 49-026 Lithium RAM battery (3V)
16. 35-0486 Main board (for unit w/o pump)
17. 35-0491 Main board (for unit w/pump)
18. 10-435 Back cover
19. 05-1147 Back cover screws (7)
20. 55-396 Belt clip
21. 05-213 Washer (2)
22. 05-035_P4 Belt clip screw (2)

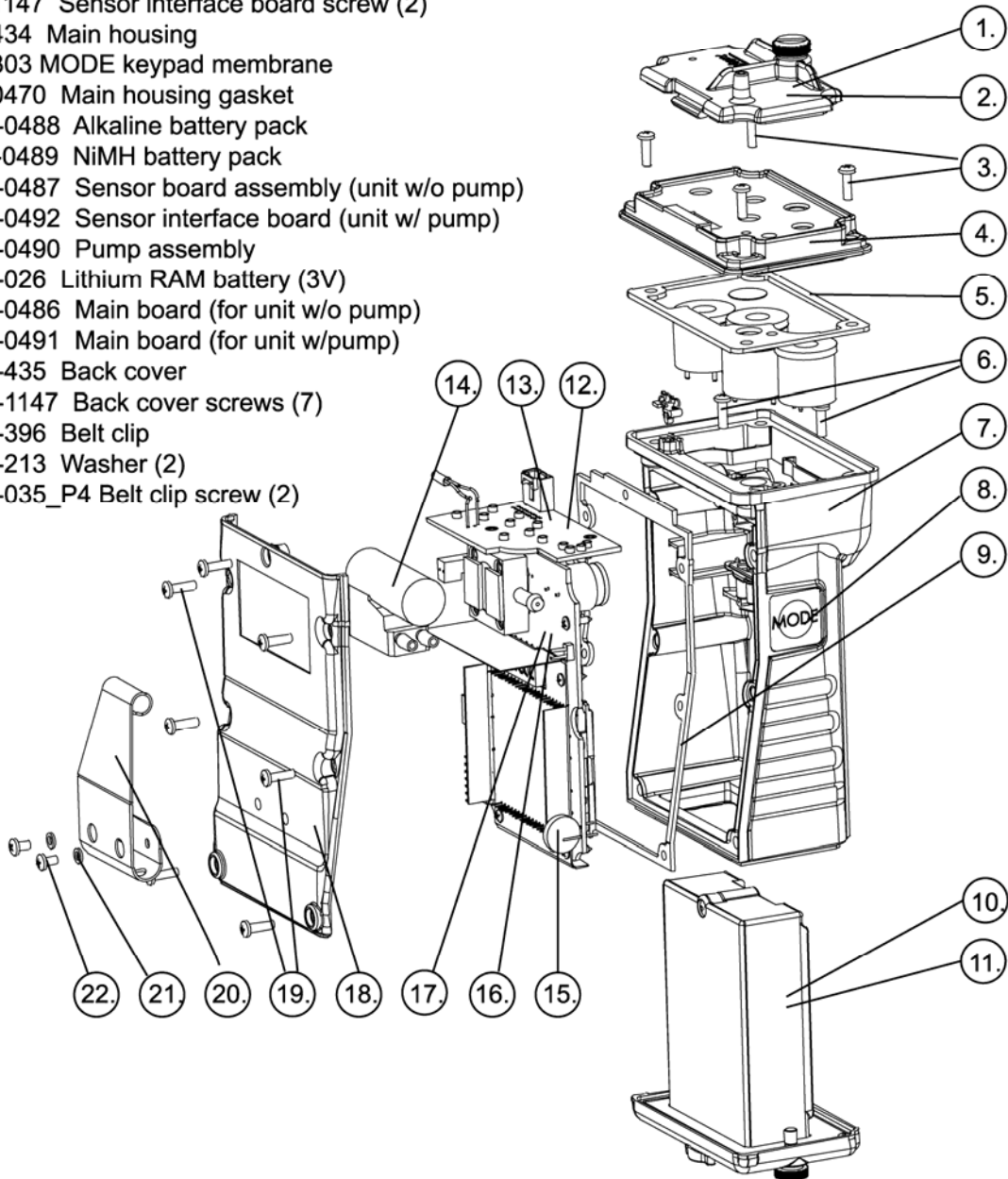

Appendices

Appendix A Toxic gas measurement – Warning, Danger, STEL and TWA alarms

Many toxic substances are commonly encountered in industry. The presence of toxic substances may be due to materials being stored or used, the work being performed, or may be generated by natural processes. Exposure to toxic substances can produce disease, bodily injury, or death in unprotected workers.

It is important to determine the amounts of any toxic materials potentially present in the workplace. The amounts of toxic materials potentially present will affect the procedures and personal protective equipment that must be used. The safest course of action is to eliminate or permanently control hazards through engineering, workplace controls, ventilation, or other safety procedures.

Unprotected workers may not be exposed to levels of toxic contaminants that exceed Permissible Exposure Limit (PEL) concentrations. Ongoing monitoring is necessary to insure that exposure levels have not changed in a way that requires the use of different or more rigorous procedures or equipment.

Airborne toxic substances are typically classified on the basis of their ability to produce physiological effects on exposed workers. Toxic substances tend to produce symptoms in two time frames.

Higher levels of exposure tend to produce immediate (acute) effects, while lower levels of long-term (chronic) exposure may not produce physiological symptoms for years.

Hydrogen sulfide (H₂S) is a good example of an acutely toxic substance which is immediately lethal at relatively low concentrations. Exposure to a 1,000 ppm (parts per million) concentration of H₂S in air produces rapid paralysis of the respiratory system, cardiac arrest, and death within minutes.

Carbon monoxide (CO) is a good example of a chronically toxic gas. Carbon monoxide bonds to the hemoglobin molecules in red blood cells. Red blood cells contaminated with CO are unable to transport oxygen. Although very high concentrations of carbon monoxide may be acutely toxic, and lead to immediate respiratory arrest or death, it is the long term physiological effects due to chronic exposure at lower levels that take the greatest toll of affected workers. This is the situation with regards to smokers, parking garage attendants, or others chronically exposed to carbon monoxide in the workplace. Exposure levels are too low to produce immediate symptoms, but small repeated doses reduce the oxygen carrying capacity of the blood over time to dangerously low levels. This partial impairment of the blood supply may lead over time to serious physiological consequences.

Because prudent monitoring programs must take both time frames into account, there are two

independent exposure measurements and alarm types built into the MultiPro design.

1. Warning and Danger Alarms:

OSHA has assigned some, but not all, toxic substances with a ceiling level which represents the highest concentration of a toxic substance to which an unprotected worker should ever be exposed, even for a very short time. The default Warning and Danger alarm levels in the MultiPro are less than or equal to the OSHA-assigned ceiling levels for both CO and H₂S. **Never enter an environment even momentarily when concentrations of toxic substances exceed the level of either the Warning or the Danger Alarm.**

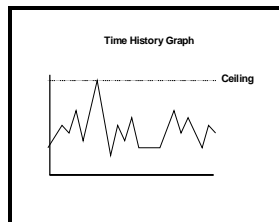

2. Time Weighted Average (TWA):

The maximum average concentration to which an unprotected worker may be exposed over an eight hour working day is called the Time Weighted Average or TWA value. TWA values are calculated by taking the sum of exposure to a particular toxic gas in the current operating session in terms of parts-per-million-hours and dividing by an eight-hour period.

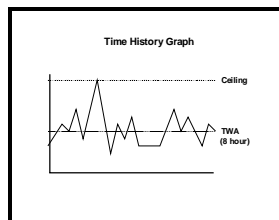

3. Short Term Exposure Limits (STEL):

Toxic substances may have short term exposure limits which are higher than the eight hour TWA. The STEL is the maximum average concentration to which an unprotected worker may be exposed in any fifteen minute interval during the day. During this time, neither the eight hour TWA or the ceiling concentration may be exceeded.

Any fifteen minute periods in which the average STEL concentration exceeds the permissible eight hour TWA must be separated from each other by at least one hour. A maximum of four of these periods are allowed per eight hour shift.

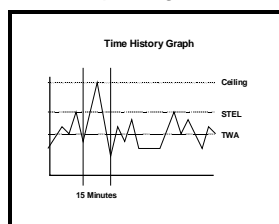

Appendix B Calibration Frequency Recommendation

One of the most common questions that we are asked at Sperian Instrumentation is: **“How often should I calibrate my gas detector?”**

Sensor Reliability and Accuracy

Today’s sensors are designed to provide years of reliable service. In fact, many sensors are designed so that with normal use they will only lose 5% of their sensitivity per year or 10% over a two-year period. Given this, it should be possible to use a sensor for up to two full years without any significant loss of sensitivity.

Verification of Accuracy

With so many reasons why a sensor can lose sensitivity and given the fact that dependable sensors can be key to survival in a hazardous environment, frequent verification of sensor performance is paramount.

There is only one sure way to verify that a sensor can respond to the gas for which it is designed. That is to expose it to a known concentration of target gas and compare the reading with the concentration of the gas. This is referred to as a “bump” test. This test is very simple and takes only a few seconds to accomplish. **The safest course of action is to do a “bump” test prior to each day’s use***. It is not necessary to make a calibration adjustment if the readings fall between 90%** and 120% of the expected value. As an example, if a CO sensor is checked using a gas concentration of 50 PPM it is not necessary to perform a calibration unless the readings are either below 45 PPM or above 60 PPM.

*** The Canadian Standards Association (CSA) requires the LEL sensor to be bump tested prior to each day’s use with calibration gas containing between 25% and 50% LEL.**

**** The Canadian Standards Association (CSA) requires the instrument to undergo calibration when the displayed value during a bump test fails to fall between 100% and 120% of the expected value for the gas.**

Lengthening the Intervals between Verification of Accuracy

We are often asked whether there are any circumstances in which the period between accuracy checks may be lengthened.

Sperian Instrumentation is not the only manufacturer to be asked this question! One of the professional organizations to which Sperian Instrumentation belongs is the Industrial Safety Equipment Association (ISEA). The “Instrument Products” group of this organization has been very active in developing a protocol to clarify the minimum conditions under which the interval between accuracy checks may be lengthened.

A number of leading gas detection equipment manufacturers have participated in the development of the ISEA guidelines concerning calibration frequency. Sperian Instrumentation procedures closely follow these guidelines.

If your operating procedures do not permit daily checking of the sensors, Sperian Instrumentation recommends the following procedure to establish a safe and prudent accuracy check schedule for your Sperian instruments:

1. During a period of initial use of at least 10 days in the intended atmosphere, check the sensor response daily to be sure there is nothing in the atmosphere that is poisoning the sensor(s). The period of initial use must be of sufficient duration to ensure that the sensors are exposed to all conditions that might have an adverse effect on the sensors.
2. If these tests demonstrate that it is not necessary to make adjustments, the time between checks may be lengthened. The interval between accuracy checking should not exceed 30 days.
3. When the interval has been extended the toxic and combustible gas sensors should be replaced immediately upon warranty expiration. This will minimize the risk of failure during the interval between sensor checks.
4. The history of the instrument response between verifications should be kept. Any conditions, incidents, experiences, or exposure to contaminants that might have

an adverse effect on the calibration state of the sensors should trigger immediate re-verification of accuracy before further use.

5. Any changes in the environment in which the instrument is being used, or changes in the work that is being performed, should trigger a resumption of daily checking.
6. If there is any doubt at any time as to the accuracy of the sensors, verify the accuracy of the sensors by exposing them to known concentration test gas before further use.

Gas detectors used for the detection of oxygen deficiencies, flammable gases and vapors, or toxic contaminants must be maintained and operated properly to do the job they were designed to do. Always follow the guidelines provided by the manufacturer for any gas detection equipment you use!

If there is any doubt regarding your gas detector’s accuracy, do an accuracy check! All it takes is a few moments to verify whether or not your instruments are safe to use.

One Button Auto Calibration

While it is only necessary to do a “bump” test to ensure that the sensors are working properly, all current Sperian Instrumentation gas detectors offer a one button auto calibration feature. This feature allows you to calibrate a Sperian Instrumentation gas detector in about the same time as it takes to complete a “bump” test. The use of automatic bump test and calibration stations can further simplify the tasks, while automatically maintaining records.

Don’t take a chance with your life. Verify accuracy frequently!

Please read also Sperian Instrumentation’s application note: AN20010808 “Use of ‘equivalent’ calibration gas mixtures”. This application note provides procedures to ensure safe calibration of LEL sensors that are subject to silicone poisoning.

Sperian Instrumentation’s website is at:

<http://www.biosystems.com>

Appendix C MultiVision Sensor Information

Part No.	Description	Range	Resolution
54-42-80	LEL Combustible gas (UL-Approved Units)	0 – 100% LEL	1% LEL
54-42-81	LEL Combustible gas (ATEX-Approved Units)	0 – 100% LEL	1% LEL
54-42-90	O ₂ Oxygen	0 – 30% by Volume	0.1%
54-42-01	CO Carbon monoxide	0 – 1000 PPM	1 PPM
54-42-02	H ₂ S Hydrogen sulfide	0 – 200 PPM	1 PPM

Appendix D Toxic Sensor Cross-Sensitivity

The table below provides the cross-sensitivity response of the MultiVision toxic gas sensors to common interference gases. The values are expressed as a percentage of the primary sensitivity, or the reading of the sensor when exposed to 100ppm of the interfering gas at 20°C. These values are approximate. The actual values depend on the age and condition of the sensor. Sensors should always be calibrated to the primary gas type. Cross-sensitive gases should not be used as sensor calibration surrogates without the express written consent of Sperian Instrumentation.

SENSOR	CO	H ₂ S	SO ₂	NO	NO ₂	Cl ₂	ClO ₂	H ₂	HCN	HCl	NH ₃	C ₂ H ₄	C ₂ H ₂
Carbon Monoxide (CO)	100	10	5	10	-15	-5	-15	50	15	3	0	75	250
Hydrogen Sulfide (H₂S)	0.5	100	20	2	-20	-20	-60	0.2	0	0	0	n/d	n/d

Appendix E Basic parts list

Calibration accessories

54-41-001	MultiVision Calibration Adapter
54-41-005	MultiVision Remote Sampling Adapter (Manual sample draw)
54-41-003	MultiVision Remote Sampling Adapter (Internal pump). Includes pump activation magnet. Requires internal pump be installed in MultiVision
54-41-006	MultiVision Internal Pump Upgrade. Must be returned to Sperian Instrumentation's service department. This part number includes labor charges for upgrade.
54-41-007	MultiVision Manual Sample draw kit. Includes adapter, squeeze bulb, 10' of tubing.
54-05-A0403	Sample probe assembly. Does not include tubing, squeeze bulb, or sample draw adapter
54-05-A0405	Sample probe assembly with 11.5-inch stainless-steel probe tube. Does not include tubing, squeeze bulb, or sample draw / calibration adapter

Sensors

54-42-80	LEL	Combustible gas (UL-Approved Units)
54-42-81	LEL	Combustible gas (ATEX-Approved Units)
54-42-90	O ₂	Oxygen
54-42-01	CO	Carbon monoxide
54-42-02	H ₂ S	Hydrogen sulfide
54-42-101	MultiVision Exchange set of 4 sensors. O ₂ , LEL, CO and H ₂ S. This part number requires return of identical set of expired MultiVision sensors.	

Miscellaneous

Part No.	Description
54-41-004B	MultiVision Rubber Boot. Black
54-41-004R	MultiVision Rubber Boot. Red
54-41-004Y	MultiVision Rubber Boot. Yellow
54-41-008	MultiVision BioTrak Download software. Requires MultiVision datalogging option be installed. Computer must support IrDA to download.
54-26-0605S	Infrared communication device (Serial – IrDA) - Requires one available PC serial port.
54-26-0605U	Infrared communication device (USB – IrDA) - Requires one available USB port.

Appendix F Sperian Instrumentation Standard Gas Detection Warranty

General

Sperian Protection Instrumentation, LLC (hereafter Sperian) warrants gas detectors, sensors and accessories manufactured and sold by Sperian, to be free from defects in materials and workmanship for the periods listed in the tables below.

Damages to any Sperian products that result from abuse, alteration, power fluctuations including surges and lightning strikes, incorrect voltage settings, incorrect batteries, or repair procedures not made in accordance with the Instrument's Reference Manual are not covered by the Sperian warranty.

The obligation of Sperian under this warranty is limited to the repair or replacement of components deemed by the Sperian Instrument Service Department to have been defective under the scope of this standard warranty. To receive consideration for warranty repair or replacement procedures, products must be returned with transportation and shipping charges prepaid to Sperian at its manufacturing location in Middletown, Connecticut, or to a Sperian Authorized Warranty Service Center. It is necessary to obtain a return authorization number from Sperian prior to shipment.

THIS WARRANTY IS EXPRESSLY IN LIEU OF ANY AND ALL OTHER WARRANTIES AND REPRESENTATIONS, EXPRESS OR IMPLIED, INCLUDING BUT NOT LIMITED TO, THE WARRANTY OF FITNESS FOR A PARTICULAR PURPOSE. SPERIAN WILL NOT BE LIABLE FOR LOSS OR DAMAGE OF ANY KIND CONNECTED TO THE USE OF ITS PRODUCTS OR FAILURE OF ITS PRODUCTS TO FUNCTION OR OPERATE PROPERLY.

Instrument & Accessory Warranty Periods

Product(s)	Warranty Period
Biosystems PHD6, PhD ⁵ , PhD Lite, PhD Plus, PhD Ultra, Cannonball3, MultiVision, Toxi, Toxi/Oxy Plus, Toxi/Oxy Ultra, ToxiVision, Ex Chek	As long as the instrument is in service
ToxiPro [®] , MultiPro	2 years from date of purchase
ToxiLtd [®]	2 years after activation or 2 years after the "Must Be Activated By" date, whichever comes first
Toxi3Ltd [®]	3 years after activation or 3 years after the "Must Be Activated By" date, whichever comes first
Mighty-Tox 2 Prorated credit is given towards repair or purchase of a new unit of the same type.	0 – 6 months of use 100% credit 6 – 12 months of use 75% credit 12 – 18 months of use 50% credit 18 – 24 months of use 25% credit
IQ Systems, Series 3000, Airpanel, Travelpanel, ZoneGuard, Gas✓Chek1 and Gas✓Chek4	One year from the date of purchase
Battery packs and chargers, sampling pumps and other components, which by their design are consumed or depleted during normal operation, or which may require periodic replacement	One year from the date of purchase

Sensor Warranty Periods

Instrument(s)	Sensor Type(s)	Warranty Period
Biosystems PHD6, PhD Plus, PhD Ultra, PhD ⁵ , PhD Lite, Cannonball3, MultiVision, MultiPro, ToxiVision, ToxiPro [®] , Ex Chek	O ₂ , LEL**, CO, CO+, H ₂ S & Duo-Tox	2 Years
	All Other Sensors	1 Year
Toxi, Toxi/Oxy Plus, Toxi/Oxy Ultra	CO, CO+, H ₂ S	2 Years
	All Other Sensors	1 Year
All Others	All Sensors	1 Year

** Damage to combustible gas sensors by acute or chronic exposure to known sensor poisons such as volatile lead (aviation gasoline additive), hydride gases such as phosphine, and volatile silicone gases emitted from silicone caulks/sealants, silicone rubber molded products, laboratory glassware greases, spray lubricants, heat transfer fluids, waxes & polishing compounds (neat or spray aerosols), mold release agents for plastics injection molding operations, waterproofing formulations, vinyl & leather preservatives, and hand lotions which may contain ingredients listed as cyclomethicone, dimethicone and polymethicone (at the discretion of Sperian's Instrument Service department) void Sperian Instrumentation's Standard Warranty as it applies to the replacement of combustible gas sensors.